



Pronomic HP-2000 Power Amplifier

ArtNo: 00083670



Operating instructions

Version 09/2024

© 2024

Thank you for purchasing this product. To ensure that you are completely satisfied with this product, please read this manual carefully.

This manual is protected by copyright. Copying or reprinting, even in excerpts, is only permitted with the consent of Musikhaus Kirstein GmbH. The same applies to the reproduction or copying of images, even in modified form.

Content

Connections and Controls	4
Processing Switch Diagram (Item 6, Page 5)	6
Technical Specifications	7
Rack Mounting	8
Connection Examples	8
Stereo Mode	9
Bridged Mono Mode	9
Circuit Diagram	10
WEEE Declaration	11



The signal word **WARNING** indicates hazards that can lead to serious injuries if no precautionary measures are taken.



The signal word **NOTE** indicates general precautions that should be observed when handling the product.



Images and screen representations in this manual may differ slightly from the appearance of the actual product, as long as this does not negatively affect the technical characteristics and safety of the product.



All person-related formulations in these operating instructions are to be regarded as gender-neutral.

These operating instructions apply to mature users and to persons who have been supervised or instructed in the operation of the device by a person responsible for their safety and who have proven that they are able to handle the device.



**Children should be supervised to ensure that they do not use this device as a toy.
Never allow children to play with the packaging material unsupervised.**



Risk of damage to property! We are not liable for accidents that occur because of non-compliance with the safety instructions or incorrect handling.

All information in these operating instructions has been checked to the best of our knowledge and belief. However, neither the author nor the publisher can be held liable for any damages in connection with the use of these operating instructions.

Other product, brand and company names mentioned in this document may be the trademarks of their respective owners. Compliance with all applicable copyright laws is the responsibility of the user of this document.

Do not disassemble or modify the product. Doing so could result in injury from electric shock.

If you notice that the power cord shows obvious signs of wear, the product malfunctions or has an unpleasant odor, something has fallen into the product, the product has been exposed to rain, the product shows obvious changes in performance, or the product has been dropped, unplug the product from the wall outlet immediately and refer servicing to qualified service personnel or your dealer for repair, service, or maintenance.

Before cleaning the product, please turn it off and disconnect it from the power supply. Clean the product only with a soft, dry cloth. Do not use paint thinner, solvents, cleaning fluids or chemically impregnated wipes.

Always place the product on a flat, stable surface to ensure safe standing.

Do not use the product in a damp or wet environment.

Do not place any objects on the device that could fall into it and do not allow any liquids to penetrate the inside of the housing.

Do not expose the product to the following conditions to avoid deformation, discoloration, or major damage:

Direct sunlight, extreme temperature or humidity, excessively dusty or dirty places, strong vibration or shock, strong magnetic fields.

Do not place the item near other electrical equipment to avoid interference.

Do not use force or place heavy objects on the product when handling it.

Unplug this apparatus during lightning storms or when unused for long periods of time. Please pull the plug, not the cable.

Please handle the power cable with care. It should not be placed near radiators, you should not place heavy objects on it, and it should be laid in such a way that no persons can step on it or fall over it.

Connect the AC adapter only to a power outlet with the correct voltage.

Do not apply excessive force to controls such as switches, knobs, buttons, mounting screws.

This product, when used with headphones or speakers, may produce sound levels that can cause permanent hearing loss. Do not operate the device at a high volume or at a level that is uncomfortable for an extended period. Seek medical attention if you experience hearing loss or ringing in the ears.

The appliance should be installed in such a way as to ensure good ventilation.

Make sure in advance that the speaker, the connections, and the wiring are suitable for the power amp's output, otherwise damage may occur.

Connections and Controls

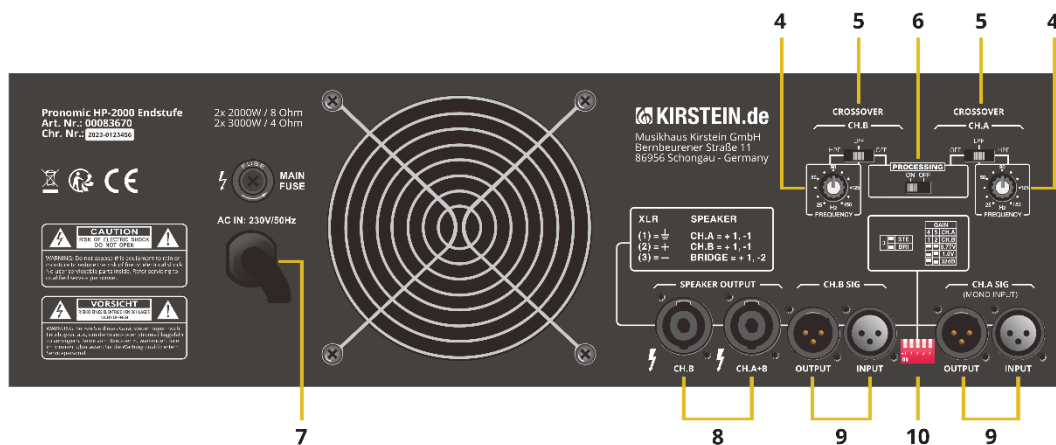
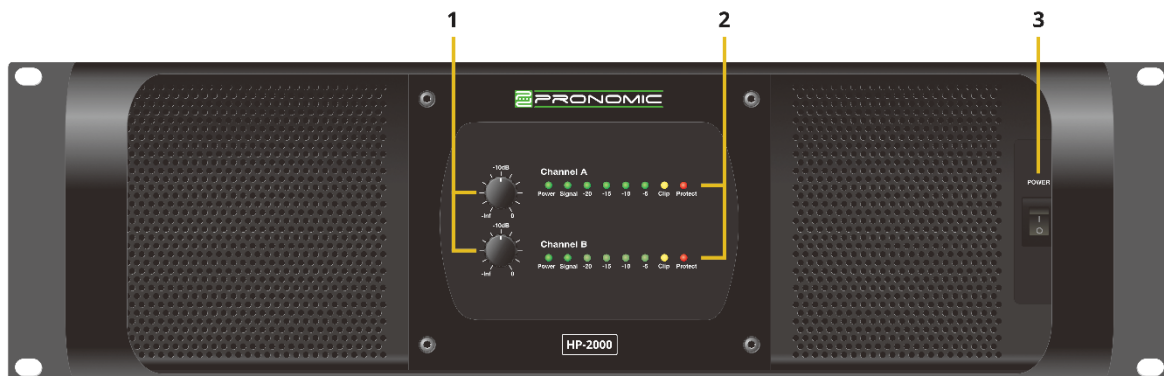

1. Level control

These controls adjust the level of each channel (displayed in dB). Turn these knobs counterclockwise when the Limit LEDs are constantly lit, as this indicates that the input signal is too strong.

2. LED signal display

The POWER LEDs light when the amplifier is ON. The SIGNAL LEDs light to confirm the presence of an input signal greater than 100 mV on that channel of the amplifier.

Displayed are -20dB, -15dB, -10dB and -5dB.

3. Power switch

Use this switch to turn the unit on or off. Turn the level controls to 0 before turning the power on. A momentary mute is normal when the amplifier is turned on or off.

Attention: Always switch on the power amplifier after all other connected devices. Always switch off the power amplifier before all other connected devices.

4. Frequency controller

These controls allow you to set the cutoff frequency for each channel (A and B).

5. Filter switch

This switch allows you to select the filter type for each channel (A and B).

Off = No filters

High Cut = low pass filter. The amplifier outputs the frequencies that are lower than the cut-off frequency set with the frequency controller.

Low Cut = high pass filter. The amplifier outputs the frequencies that are higher than the cut-off frequency set with the frequency controller.

If you select "High Cut" or "Low Cut", you can use the frequency controller to adjust the crossover frequency. The setting range is between 25 Hz and 150 Hz. When the amplifier is in Bridge mode, only the Channel A switch and knob are active.

6. Processing switch

To better illustrate the function of the Processing switch, please refer to the diagram on the next page.

When the Processing switch is in the "ON" position, 6dB is raised to 60 Hz.

If you move the Processing switch to the "Off" position, the signal is looped directly through. The filter switch mentioned under point 5 has no function in this position.

7. Mains connection

Use this cable to supply power to the power amplifier.

8. Loudspeaker output

Use these Speakon compatible connectors to connect to external speakers.

9. Balanced channel inputs (Input) and channel outputs (Output)

These XLR jacks are balanced. You can parallel this power amplifier with other amplifiers by outputting the signal through the Output jacks to the input terminals of the other amplifier. Balanced connections are recommended as they are less susceptible to AC hum. For long cable runs, an output impedance of less than 600 ohms is required to avoid signal loss. For stereo operation, inputs CH-1 and CH-2 are used, while for bridged mono operation, only input CH-1 is used.

10. Mode selector switch

These switches on the rear of the unit allow the maximum achievable gain to be set directly in the input stage. The output stage has a 0.77V and a 1.0V voltage gain setting as well as a 32dB sensitivity setting.

You can choose between the two operating modes "Stereo" and "Bridged".

To do this, slide the switch to the appropriate position.

- Stereo Mode: This mode allows independent control of 2 separate signals, such as stereo playback, main and monitor live mixes, and bi-amp operation (highs in one channel and lows in the other).

- Bridged Mono Mode: This mode combines the power of both channels to drive a single speaker.

Therefore, make sure in advance that the speaker, connections and cabling are suitable for this power, otherwise damage may occur.

Processing Switch Diagram (Item 6, Page 5)

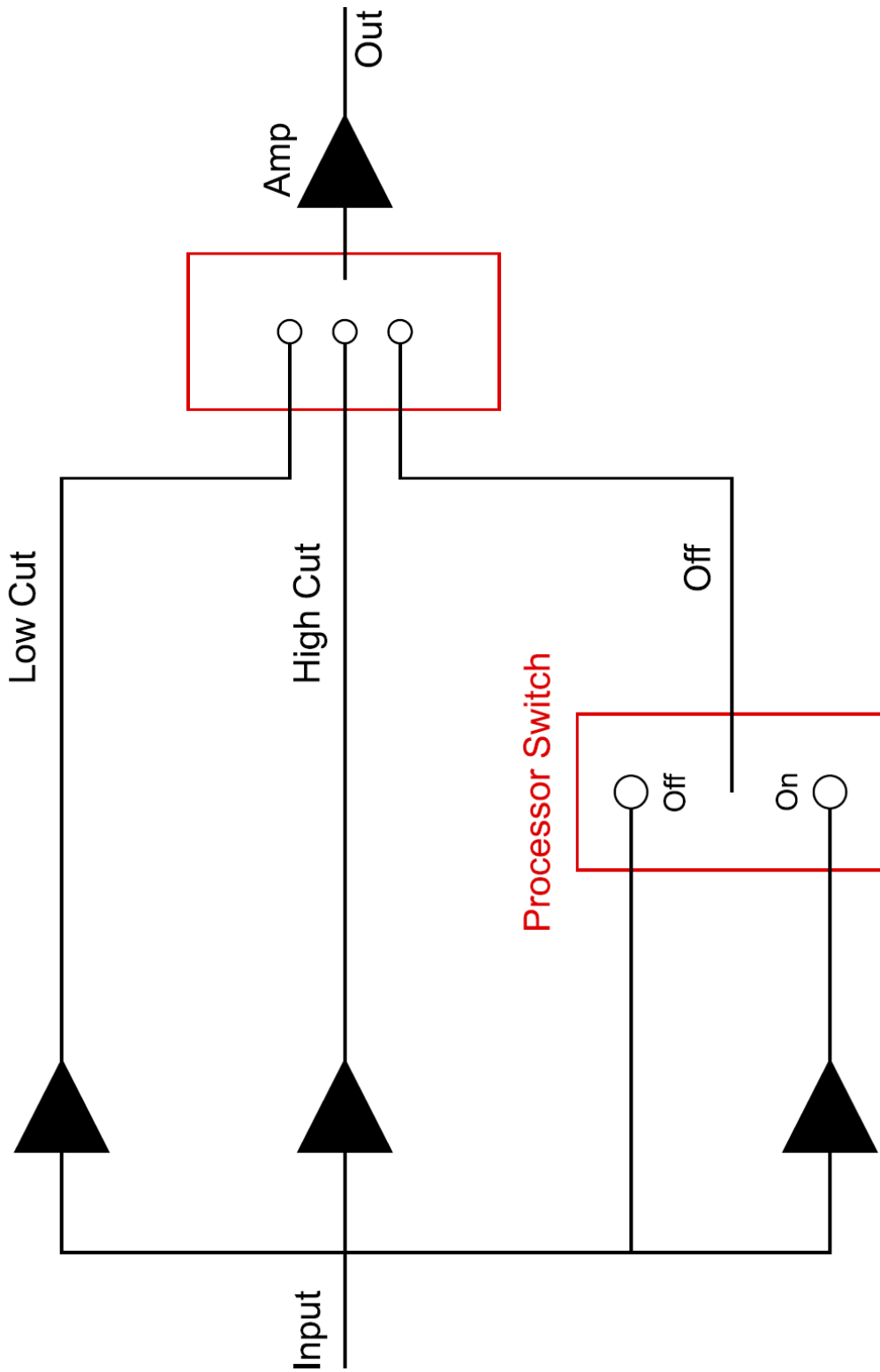

Technical Specifications

Output power (8 Ohm)	2x 2000W
Output power (4 Ohm)	2x 3000W
Output power (8 Ohm/bridged)	6000W
Output power (4 Ohm/bridged)	9000W
Frequency response (1W at 8 Ohm)	20 Hz - 20 kHz \pm 0.5dB
THD 20 Hz - 20 kHz for 1 W	< 0,1 %
THD at 1 kHz and 1 dB under clipping	< 0,05 %
Signal to noise ratio	> 103 dbA
Input sensitivity	Selectable (0.77V, 1.0V, 32db)
Input impedance	20 k Ohm
Input connections	XLR female, 3-pin
Max. voltage gain at 0.775V input voltage (8 Ohm)	42,7 dB
Max. voltage gain at 1V input voltage (8 Ohm)	40,3 dB
Max. voltage gain at 1.44V input voltage (8 Ohm)	32 dB
Max. output voltage (4 Ohm)	119,7 V
Max. output voltage (8 Ohm)	119,7 V
Damping factor	>230
Type of output circuit	Class D
Output ports	XLR male, 3-pin
Loudspeaker connections	Speakon compatible, 2-pin
LED indicators per channel	On, Signal, Level, Clip, Protect
Mains voltage	230 VAC/50 Hz
Dimension	482 x 395 x 132 mm
Weight	31.7 kg
Panel Controls	Mode selection
Cooling	One fan, airflow from front to back, temperature-controlled speed
Protection	Short circuit, open circuit, thermal, Soft-Start, DC voltage, Overcurrent compression, Topping distortion compression (clipping distortion compression)

Rack Mounting

This power amplifier is suitable for mounting in 19" standard racks as well as for "stack" mounting without rack.

Use 4 screws and washers for mounting on the front rack rails. We recommend to secure the unit additionally at the rear or bottom side, as the power amplifier is exposed to strong vibrations especially during mobile use.

If you are mounting the unit in a rack, please make sure that you open the rear door fully to ensure proper ventilation.

Connection Examples

The following examples describe the most common ways to use your power amplifier in a sound system.

Turn off the power amplifier before making any connections.

The unit can be operated in one of two modes (stereo and bridged mono). Refer to the following speaker terminal wiring diagrams depending on which mode you want to use.

Attention: Musikhaus Kirstein GmbH accepts no liability for damaged loudspeakers caused by improper wiring, careless use, failure to observe the permissible power rating, or similar.

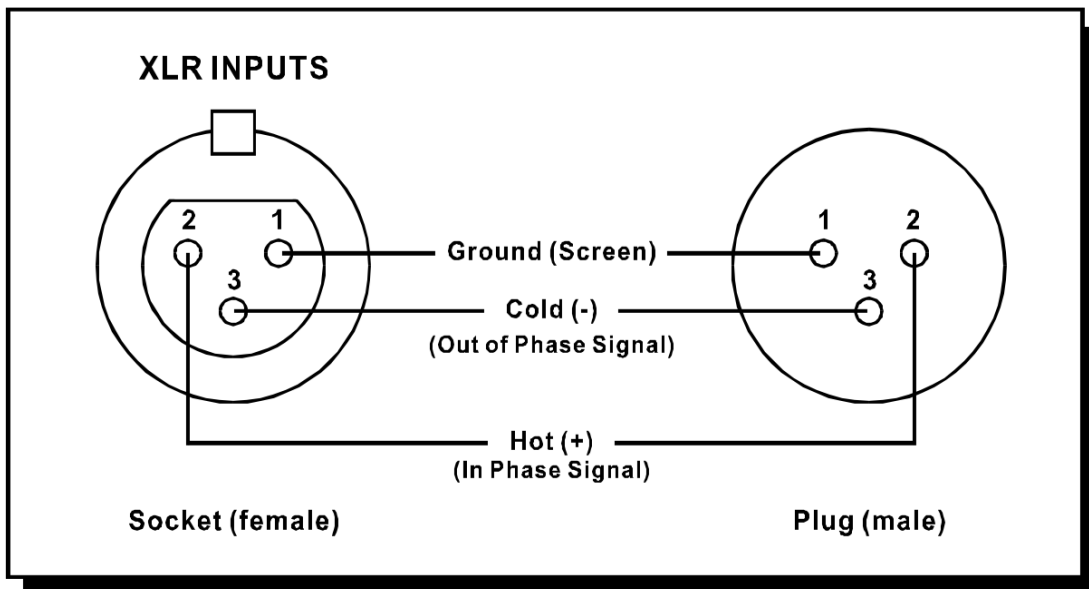

Stereo Mode

To operate the unit in stereo mode, first turn off the power amplifier, then slide the mode selector switch to the upper "stereo" position and connect the wiring properly as shown in the following diagram.

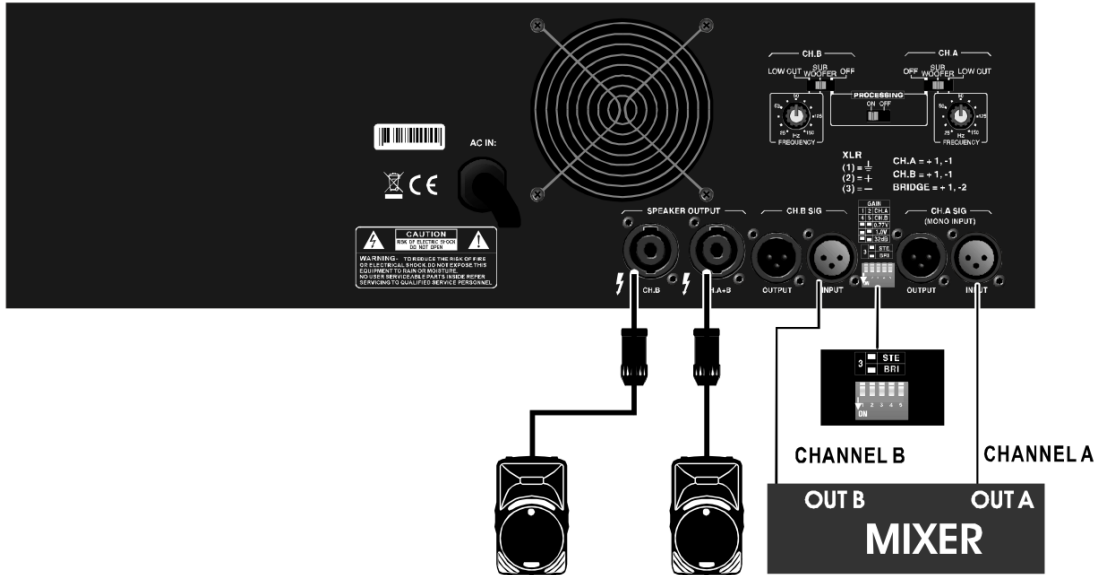

Bridged Mono Mode

First, turn off the power and slide the mode selector switch to the lower "Bridged" position and connect the wiring properly as shown in the following diagram. The signal is input to CH-1, so turn the Channel 2 level control all the way down (counterclockwise).

Caution: This mode produces high power. Make sure your wiring and speaker are rated for it.

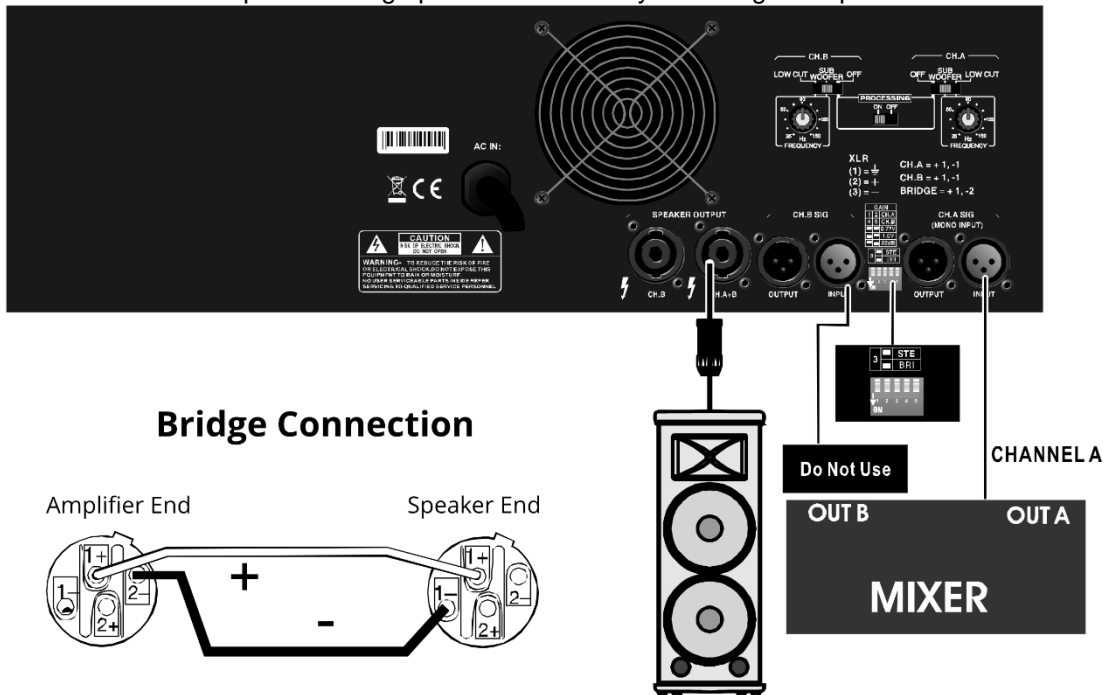

Circuit Diagram

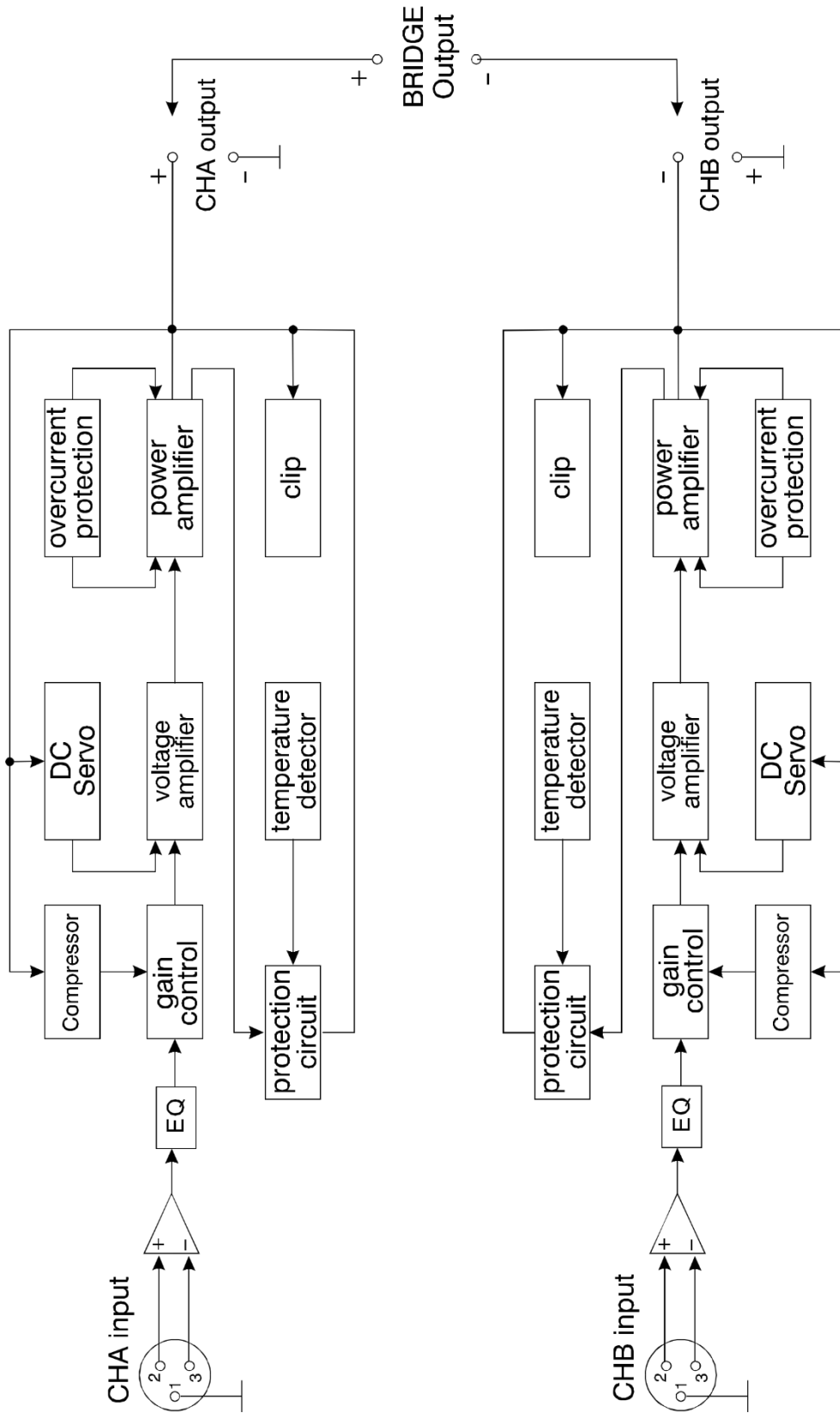

WEEE Declaration

(Waste of Electrical and Electronic Equipment)

Your product has been designed and manufactured using high quality materials and components that are recyclable and reusable. The symbol means that your product must be disposed of separately from household waste at the end of its life. Dispose of this device at your local collection or recycling point.

Please help protect the environment in which we all live.

All specifications and appearances are subject to change without notice. All information was correct at the time of going to press. Musikhaus Kirstein GmbH does not warrant the accuracy or completeness of the descriptions, photographs or statements contained in this manual. Printed colors and specifications may vary slightly from the product. Products of Musikhaus Kirstein GmbH are sold only through authorized distributors. Distributors and dealers are not representatives of Musikhaus Kirstein GmbH and are not authorized to legally bind Musikhaus Kirstein GmbH in any way.

KIRSTEIN.de

Musikhaus Kirstein GmbH
Bernbeurener Straße 11
86956 Schongau - Germany
Telefon: 0049-8861/909494-0
info@kirstein.de

