



EK-6100 Keyboard



User Manual

Art.Nr.: 00061845 - McGrey EK-6100 Economic-Keyboards, 61 Tasten

00061846 - McGrey SK-6100 Super Kit, 61 Tasten Keyboard Set

Version: 08/2019

Precautions

Read it carefully before proceeding.

- Only apply the designated power supply adaptor. Change it whenever it shows any wear and tear, or goes wrong.
- Neither disassemble the instrument nor make any change inside of it. In case of any anomalous function, stop using immediately and have it repaired by the qualified maintenance personnel.
- Make sure that the both are power off when connecting the instrument with other amplifiers.
- Don't leave the volume working in maximum or in uncomfortable stage for long time.
- Keep the instrument away from the heats, which may result in the damage of the components.
- Stop any liquid, or other particles getting into the instrument, which may corrode the body or result in short circuit .
- Unplug the instrument before cleaning it and avoid using wet hands to plug or unplug it.
- Clean the instrument with a piece of dry and soft cloth without paint, alcohol or other chemical steep.
- Turn off and unplug the instrument after performance or for a long time of leaving it unused.
- Warning! Do not get it close to the ear! Misuse may cause damage to hearing.
- The supply terminals are not to be short-circuited.
- The packing has to be kept since it contains important information.
- To reduce the risk of fire or electric shock, do not expose this apparatus to rain or moisture. The apparatus shall not be exposed to dripping or splashing and that no objects filled with liquids, such as vases, shall be placed on the apparatus.
- Maximum Operating Temperature:40°C
- Direct plug-in adaptor is used as disconnect device, the disconnect device shall remain readily operable.
- Do not install this equipment in a confined space such as a book case or similar unit, and remain a well ventilation conditions. The ventilation should not be impeded by covering the ventilation openings with items such as newspaper, table-cloths, curtains etc.
- Correct Disposal of this product. This marking indicates that this product should not be disposed with other household wastes throughout throughout the EU. To prevent possible harm to the environment or human health from uncontrolled waste disposal, recycle it responsibly to promote the sustainable reuse of material resources. To return your used device, please use the return and collection systems or contact the retailer where the product was purchased. They can take this product for environmental safe recycling.

Warning: Batteries shall not be exposed to excessive heat such as sunshine, fire or the like.

Caution: Danger of explosion if battery is incorrectly replaced. Replace only with the same or equivalent type. **Warning:** Excessive sound pressure from earphones and headphones can cause hearing loss.

Content Pages

I. Panel Controls and Terminals	Page 4
II. Preparation for Performance	Page 6
III. Basic Operation	Page 7
IV. Auto-Rhythm	Page 8
V. Auto Chord	Page 10
VI. Applying Voice Effect	Page 10
VII. Recording and Programming	Page 10
VIII. Intelligent Guide Function	Page 11



I. Panel Controls and Terminals

●Front Panel Control

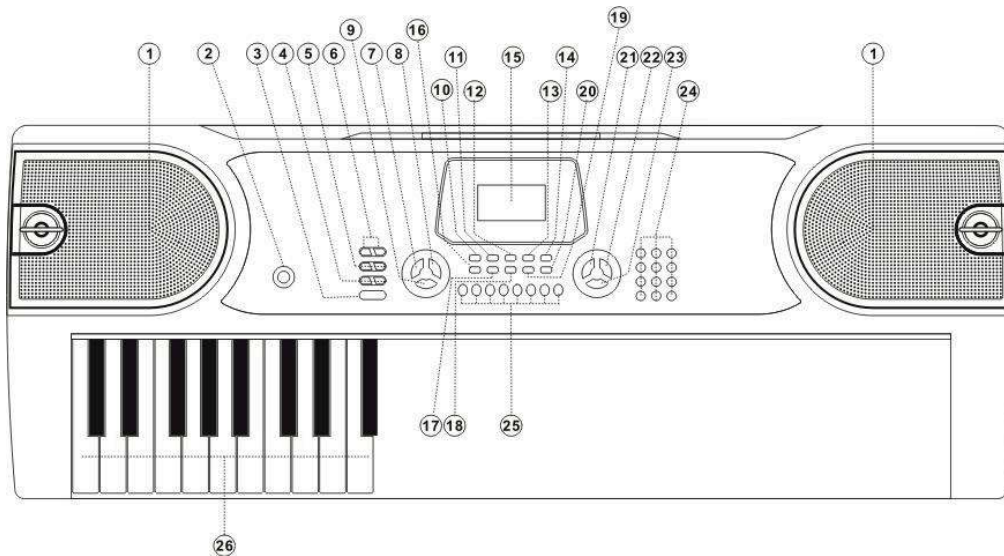

- 1. Speakers
- 2. **[POWER]** switch
- 3. **[KEYBOARD PERCUSSION]** button
- 4. **[TEMPO]** button
- 5. **[ACCOM VOL]** buttons
- 6. **[MASTER VOL]** buttons
- 7. **[SYNC]** button
- 8. **[FILL-IN]** button
- 9. **[START / STOP]** button
- 10. **[SUSTAIN]** button
- 11. **[VIBRATO]** buttons
- 12. **[ONE KEY]** button
- 13. **[FOLLOW]** button
- 14. **[ENSEMBLE]** button
- 15. LCD Screen
- 16. **[SINGLE CHORD]** button
- 17. **[FINGRED CHORD]** button
- 18. **[REC]** button
- 19. **[PROG]** button
- 20. **[PLAY]** button
- 21. **[TIMBRE]** button
- 22. **[RHYTHM]** button
- 23. **[DEMO SONG]** button
- 24. Numeric pads
- 25. Panel Percussion buttons
- 26. Chord Section

●Rear-Panel:

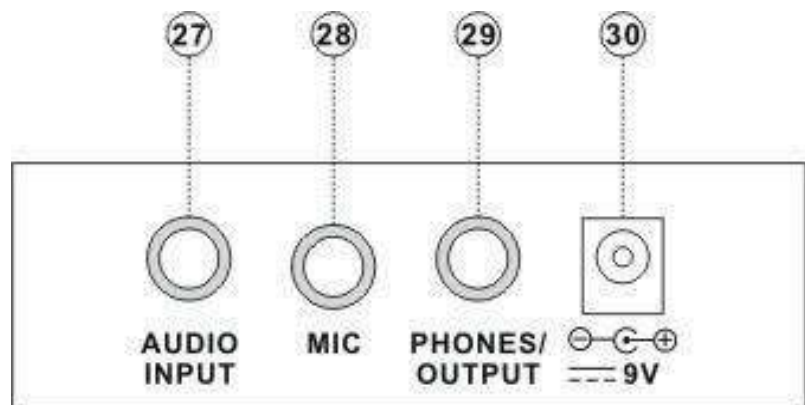

- 27. **[AUDIO INPUT]** jack
- 28. **[MIC]** jack
- 29. **[PHONES/OUTPUT]** jack
- 30. **[DC 9V]** jack

Timbre List

000-104	135 Celesta 3	167 Synth Strings 2	199 Reverse Cymbal	231 Electric Guitar (Muted) 2
Refer to the unit panel	136 Glockenspiel 1	168 Choir Aahs 1	200 Bassoon 2	232 Electric Guitar (Clean) 4
105 Wind Organ	137 Marimba 3	169 Voice Oohs 1	201 English Horn 3	233 Electric Guitar (Jazz) 2
106 Viola Attack	138 Xylophone 2	170 Synth Voice 1	202 Oboe 2	234 Acoustic Guitar (Steel) 2
107 Bari & Tenor	139 Tubular Bells 2	171 Orchestra Hit 1	203 Baritone Sax 2	235 Acoustic Guitar (Nylon) 2
108 Soft Sax 2	140 Dulcimer 3	172 Trombone 1	204 Tenor Sax 3	236 Tango Accordion 2
109 Attack Harp 2	141 Drawbar Organ 1	173 Tuba 1	205 Soprano Sax 2	237 Harmonica 2
110 Didgeridoo 2	142 Percussive Organ 1	174 Muted Trumpet 1	206 Synth Brass 3	238 Reed Organ 4
111 Dual Horns 2	143 Rock Organ 1	175 French Horn 1	207 Brass Section 2	239 Church Organ 2
112 Hard Barsoon 2	144 Church Organ 1	176 Brass Section 1	208 French Horn 2	240 Rock Organ 2
113 Kawala 2	145 Reed Organ 3	177 Synth Brass 2	209 Muted Trumpet 2	241 Percussive Organ 2
114 Soft Guitar 2	146 Harmonica 1	178 Soprano Sax 1	210 Tuba 2	242 Drawbar Organ 2
115 Mute Barafon 2	147 Tango Accordion 1	179 Tenor Sax 2	211 Trombone 2	243 Dulcimer 4
116 Lead (Sawtooth)	148 Acoustic Guitar (Nylon) 1	180 Baritone Sax 1	212 Orchestra Hit 2	244 Tubular Bells 3
117 Lead (Calliope)	149 Acoustic Guitar (Steel) 1	181 Oboe 1	213 Synth Voice 2	245 Xylophone 3
118 Lead (Bass+Lead)	150 Electric Guitar (Jazz) 1	182 English Horn 2	214 Voice Oohs 2	246 Marimba 4
119 Pad (Warm)	151 Electric Guitar (Clean) 3	183 Bassoon 1	215 Choir Aahs 2	247 Glockenspiel 2
120 Sitar	152 Electric Guitar (Muted) 1	184 Piccolo	216 Synth Strings 3	248 Celesta 4
121 Banjo	153 Overdriven Guitar 1	185 Flute	217 Synth Strings 4	249 Clavi 4
122 Shamisen 2	154 Distortion Guitar 1	186 Recorder	218 String Ensemble 3	250 Harpsichord 3
123 Koto 3	155 Electric Bass (Pick) 1	187 Pan Flute	219 Timpani 2	251 Chorused Piano 2
124 Kalimba 3	156 Fretless Bass 1	188 Blown Bottle	220 Pizzicato Strings 2	252 Rhodes Piano 2
125 Bag Pipe 2	157 Slap Bass 1	189 Shakuhach	221 Tremolo Strings 2	253 Honky-tonk Piano 2
126 Fiddle	158 Slap Bass 2	190 Whistle	222 Contrabass 2	254 Electric Grand Piano 2
127 Shanai 2	159 Synth Bass 1	191 Ocarina	223 Synth Bass 3	
128 Trumpet 2	160 Synth Bass 2	192 Tinkle Bell	224 Synth Bass 4	
129 Electric Grand Piano 1	161 Contrabass 1	193 Agogo	225 Slap Bass 3	
130 Honky-tonk Piano 1	162 Tremolo Strings 1	194 Steel Drums	226 Slap Bass 4	
131 Rhodes Piano 1	163 Pizzicato Strings 1	195 Woodblock 2	227 Fretless Bass 2	
132 Chorused Piano 1	164 Timpani 1	196 Taiko Drum	228 Electric Bass (Pick) 2	
133 Harpsichord 2	165 String Ensemble 2	197 Melodic Tom	229 Distortion Guitar 2	
134 Clavi 3	166 Synth Strings 1	198 Synth Drum	230 Overdriven Guitar 2	

Rhythm List

000-125	153 Pasodoble 2	182 68 Beat Ballad 1	211 Jazz Big Band 3	240 Rumba 3
Refer to the unit panel	154 Samba 3	183 Big Band Ballad 1	212 Pub Piano 3	241 Club Dance 3
126 Blue Grass 5	155 Samba 4	184 West Shuffle	213 Swing Beat 2	242 USA March 3
127 Blue Grass 6	156 Schlager Rock 3	185 Calypso	214 Slow & Easy 3	243 Uk pop 3
128 Slow Soul 2	157 SchlagerAlp 1	186 Casa	215 Reggae 3	244 Pop New Age 3
129 Bright Pop 1	158 Tarantella 2	187 Christon	216 Rock Ballad 3	245 Dixie Jazz 3
130 Club Latin 2	159 Tijuana Beat 1	188 Detroit	217 R&B Ballad 3	246 Disco Samba 3
131 Disco Chocolate 2	160 Electro Pop 2	189 Dance Pop	218 Piano Ballad 3	247 Disco Party 3
132 Disco Fox 2	161 Fusion 2	190 Espag Nol	219 Acoustic Ballad 3	248 Disco Latin 3
133 Disco Funk 2	162 Hip Beat 1	191 Fast Gospel	220 Limbo Rock 3	249 Disco Hands 3
134 Disco Hands 2	163 Limbo Rock 2	192 Ground Beat	221 Hip Beat 2	250 Disco Funk 3
135 Disco Latin 2	164 Acoustic Ballad 2	193 Guad Dance	222 Fusion 3	251 Disco Fox 3
136 Disco Party 2	165 Piano Ballad 2	194 Modern Cha Cha	223 Electro Pop 3	252 Disco Chocolate 3
137 Disco Samba 2	166 R&B Ballad 2	195 Merengue	224 Tijuana Beat 2	253 Club Latin 3
138 Dixie Jazz 2	167 Rock Ballad 2	196 Ballet	225 Tarantella 3	254 Bright Pop 2
139 Pop New Age 2	168 Reggae 2	197 Rave	226 SchlagerAlp 2	
140 Uk pop 2	169 Slow & Easy 2	198 Sy Boogie	227 Schlager Rock 4	
141 USA March 2	170 Swing Beat 1	199 Seville	228 Samba 5	
142 Club Dance 2	171 Pub Piano 2	200 Big Band Ballad 2	229 Samba 6	
143 Rumba 2	172 Jazz Big Band 2	201 68 Beat Ballad 2	230 Pasodoble 3	
144 8 Beat Modern 2	173 Jazz Club 2	202 16 Beat Ballad 2	231 Modern R&B 3	
145 Country Ballad 2	174 Jazz Beat 1	203 68 Beat Blues 2	232 Modern Country Pop 3	
146 Hard Rock 2	175 Jazz Beat 2	204 Show Tune 3	233 Medium Jazz 3	
147 Hully Gully 2	176 Jazz Rock 2	205 Analog Ballad 3	234 Love Song 3	
148 Jive 2	177 Salsa 2	206 Salsa 3	235 Jive 3	
149 Love Song 2	178 Analog Ballad 2	207 Jazz Rock 3	236 Hully Gully 3	
150 Medium Jazz 2	179 Show Tune 2	208 Jazz Beat 3	237 Hard Rock 3	
151 Modern Country Pop 2	180 68 Beat Blues 1	209 Jazz Beat 4	238 Country Ballad 3	
152 Modern R&B 2	181 16 Beat Ballad 1	210 Jazz Club 3	239 8 Beat Modern 3	

II. Preparation for Performance

● Installing batteries

The instrument requires the use of six “AA” batteries. Open the battery compartment cover on the backside and load in the batteries one by one with correct polarity. Replace the cover when the compartment is fully loaded.

Energy or voltage dissipation will result in the loss of volume and timbre distortion. Discharged or bad batteries **MUST** be replaced immediately to ensure the effect of performance. Always remove the batteries when you are not using the product for a long time.

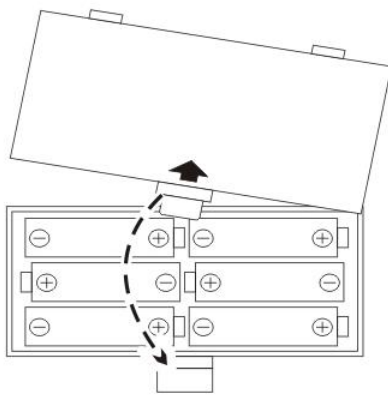

● Connecting to specified AC/DC power adaptor

Use the specified AC/DC adaptor only. Connect the output plug of the adaptor to **【DC 9V】** jack on rear-panel, then connect the other end to electrical outlet.

*Warning: the input voltage of the adaptor must be compatible with locale.

● Connecting to the earphones or outputs

◆Connecting to earphones: Connect earphones to the **【PHONES】** jack. The internal stereo speakers will be automatically shut off when earphones are plugged into the **【PHONES】** jack.

* Headphone listening at high volume levels may damage your hearing!

◆Connecting to other outputs: When connecting to external amplifiers, turn off the switches of both sides and plug the right end of audio cable into **【PHONES/OUTPUT】** terminal on rear-panel and the other end to external device.

● Connecting to microphones or other input devices

◆Connecting to microphones: By connect the instrument to microphone via **【MIC】**jack, you can sing the songs while play keyboards.

◆Connecting to other input devices: The instrument is equipped with build-in stereo input function. You can use the instrument as a broadcaster by connecting it to your mobile phones, MP3, computers or any other input devices. When connecting, first turn off the instrument and plug the right end of audio cable into either side of **【AUDIO INPUT】** jack on rear-panel and the other end to external device, and then turn on the instrument again.

III. Basic Operation

Press the **【POWER】**switch to turn on the instrument with “120” appearing on the LCD screen. The instrument cannot be played until “120” displays. The instrument is equipped with power saving function. The instrument will automatically enter the sleeping mode without being touched or operated for 15 minutes. All parameters will be reset after entering the sleep mode. You can press ANY button to wake up the instrument.

● Master Volume

Press the**【MASTER VOL+】** or **【MASTER VOL-】**button to increase or decrease the master volume. Pressing **【MASTER VOL+】** and **【MASTER VOL-】**simultaneously will reset the master volume to the default value. Adjustment of master volume will also have impact on ACCMP volume.

● ACCOM Volume

Press the**【ACCOM VOL+】** or **【ACCOM VOL-】**button to increase or decrease the ACCOM volume. Pressing **【ACCOM VOL+】** and **【ACCOM VOL-】**simultaneously will reset the ACCOM volume to the default value.

● Selecting Timbres

You can select timbres at initial interface or press **【TIMBRE】** button to call up Timbre Operation. The instrument features 255 timbres from code 000 to 254. You can change the current timbre by pressing the numbers or **【+】/【-】** in the numeric pads.

● Percussions

The instrument features 8 picturesque panel percussions. Press the panel percussion buttons according to underlying pictures to punch in desirable percussions in need of realtime performance.

The instrument features 61 keyboard percussions. Press the **【KEYBOARD PERCUSSION】** button to enable the keyboard percussion function and select a sound by play corresponding the key according to underlying pictures. Press the **【KEYBOARD PERCUSSION】** button again to disenable the function.

● Demonstrations

The instrument provides 24 demonstration songs from code 00 to 23. Press the **【DEMO SONG】** button to playback all of demonstration songs in sequence. Pressing the **【DEMO SONG】** button again while demonstrating will skip the current demonstration and jump to the next song.

Press the **【START/STOP】** button again to stop the playback.

To switch to another song, press the numbers or **【+】/【-】** in the numeric pads. The chosen song will be played in a single-cycle.

IV. Auto-Rhythm

● Selecting a rhythm

The instrument features 255 rhythms varying from 000 to 254. Press **【RHYTHM】** button to call up rhythm selection function. To switch to another the rhythm, tap the corresponding number or **【+】/【-】** in the numeric pads. You can press the **【START/STOP】** button to switch between Timbre selection function or Rhythm selection function.

1. To start a rhythm

- 1) Press the **【START/STOP】** button to start the accompaniment rhythm.
- 2) Press the **【SYNC】** button to call up “SYn” display, and then press any key in the Chord Section (i.e. the leftmost 19 keys on the keyboard) to start the rhythm and accompaniment simultaneously.

2. Fill In

Press the **【FILL IN】** button to punch in an interlude during the Rhythm.

3. To stop the rhythm

Press the **[START/STOP]** button, during the Rhythm to stop rhythm immediately.

● Adjusting the Tempo











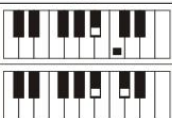

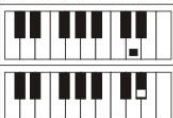
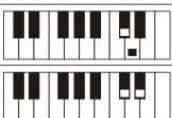
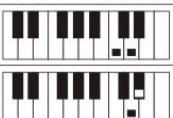
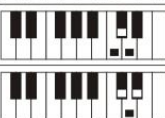



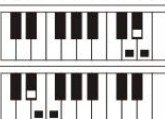













Press the **[TEMPO+]** or **[TEMPO-]** button to quicken or slow the tempo. Pressing the **[TEMPO+]** and **[TEMPO-]** button simultaneously will reset the tempo to the default value at 120 beats per minute.

V. Auto-Bass Chord

● Single Chord

When the rhythm is activated, press **[SINGLE CHORD]**. After the „Sin“ is shown on the screen, you can play a single chord on the keys in the chord zone of the keyboard. Press **[SINGLE CHORD]** again, „OFF“ will be shown on the screen, and the single chord function be disabled.

Single-Finger Chord Scales

	M	m	7	m7
C				
C#				
D				
D#				
E				
F				
F#				
G				
G#				
A				
A#				
B				

● Fingered Chord

When the rhythm is activated, press **[FINGERED CHORD]**. After the „Fin“ is shown on the screen, you can play a single chord on the keys in the chord zone of the keyboard. Press **[FINGERED CHORD]** again, „OFF“ will be shown on the screen, and the single chord function be disenabled.

Fingered Chord Scales

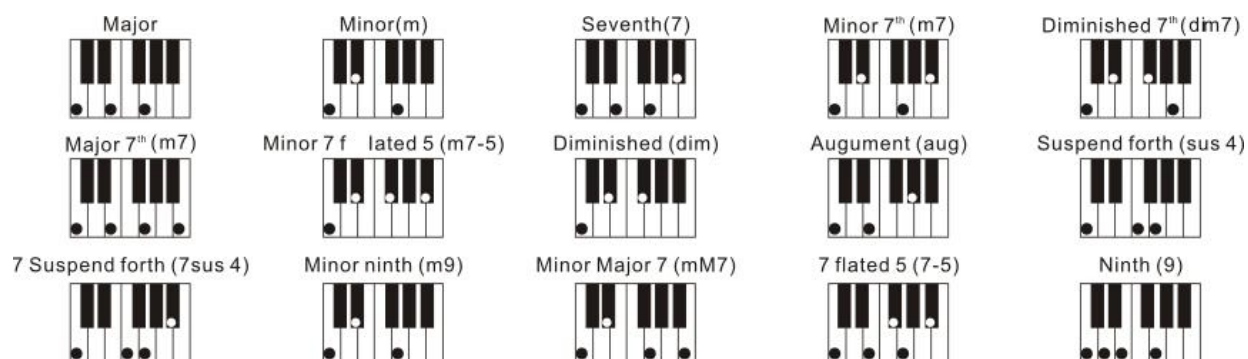

VI. Appling Voice Effect

● Sustain

Press the **[SUSTAIN]** button to add up sustain effect in your performance. Press **[SUSTAIN]** button again to disable the function.

● Vibrato

Press the **[VIBRATO]** button to add up vibrato effect in your performance. Press **[VIBRATO]** button again to disable the function.

VII. Recording and Programming

● Recording

Press the **[REC]** button to call up “rEC” display. This function allows you to record and save virtually all your performance throughout “RECORD” status. When storage is full, “FUL” will appear in the display, your recordings will thereby being stopped automatically.

Press the **[PLAY]** button to play the recorded notes with “PLA” appearing on the screen. You can press the **[PLAY]** button without finishing the record, the instrument will play back the current record and

continue the recording after the playback with “rEC” appearing on the screen. Press the **【PLAY】** button again to stop the playback.

Press the **【START/STOP】** button again to disable recording function. Your recording will be deleted after you exit from the function.

● Programming

Press the **【PROG】** button to call up “Prg” display. The Keyboard Percussions function will be enabled automatically. In this state, you can tap the corresponding keys to program up to 32 unique rhythms with “FUL” appearing on the screen.

Press the **【PLAY】** button to play back the programmed rhythms.

Press the **【START/STOP】** or press **【PROG】** button again to exit from “programming” function. The programmed songs will be deleted after you exit from the function.

VIII. Intelligent Guide Function

● One Key

Press **【ONE KEY】** button to call up ONE KEY tutorial. Select the desired song for practicing by pressing the numbers or **【+】/【-】** in the numeric pads.

With this function, you can play the melody of a Song just by pressing ANY single key in accordance with the rhythm despite of the pitch and correctness. The playback will continue by correct means as long as press any keys. Simply play a key in time with the music and the playback will continue.

Press the **【START/STOP】** button or press **【ONE KEY】** button again to exit from the Guide Function.

● Follow

Press the **【FOLLOW】** button to call up FOLLOW tutorial. Select your desired song for practicing by pressing the numbers or **【+】/【-】** in the numeric pads.

In this function, the instrument will awaits you until you can play the notes correctly. The instrument will continue the playback if you play the notes in a wrong way.

Press the **【START/STOP】** button or press **【FOLLOW】** button again to exit from the Guide Function.

● Ensemble

Press the **[ENSEMBLE]** button to enable ENSEMBLE tutorial with “GUIDE” appearing on LCD. Select the desired song for practicing by pressing the numbers or **[+]/[-]** in the numeric pads.

This function is designed for practicing both pitches and timing. When the function is selected, the song playback will mute the keynotes for ensemble and awaits you to play the notes correctly unless you cannot catch it within 3 seconds, in this occasion, the keyboard will automatically play the keynote. Press the **[START/STOP]** button or press **[ENSEMBLE]** button again to exit from the Guide Function.

WEEE-Declaration / Disposal



Your product is designed and manufactured with materials and components of high quality, which are recyclable and can be reused. The symbol means that your product should be disposed of separately from household waste when it reaches its end of life. Please dispose of this equipment at your local collection point or recycling center. Please help to protect the environment in which we all live.

All specifications and appearances are subject to change without notice. All information was correct at time of printing. Musikhaus Kirstein GmbH does not guarantee for the accuracy or completeness of any description, photograph or statement contained in this manual. Printed colors and specifications may vary slightly from product. Products from Musikhaus Kirstein GmbH are only sold through authorized dealer. Distributors and dealers are not agents of Musikhaus Kirstein GmbH and have no authority to bind Musikhaus Kirstein GmbH legally in any way. This manual is protected by copyright.

Any copying or reprint, even in excerpts, is only allowed with written consent of Musikhaus Kirstein GmbH. The same applies to reproduction or copying of images, even in altered form.

 **KIRSTEIN.de**

Musikhaus Kirstein GmbH
Bernbeurener Str. 11
86956 Schongau – Germany
Telefon/Phone: 0049-8861-909494-0
Telefax/Fax: 0049-8861-909494-19



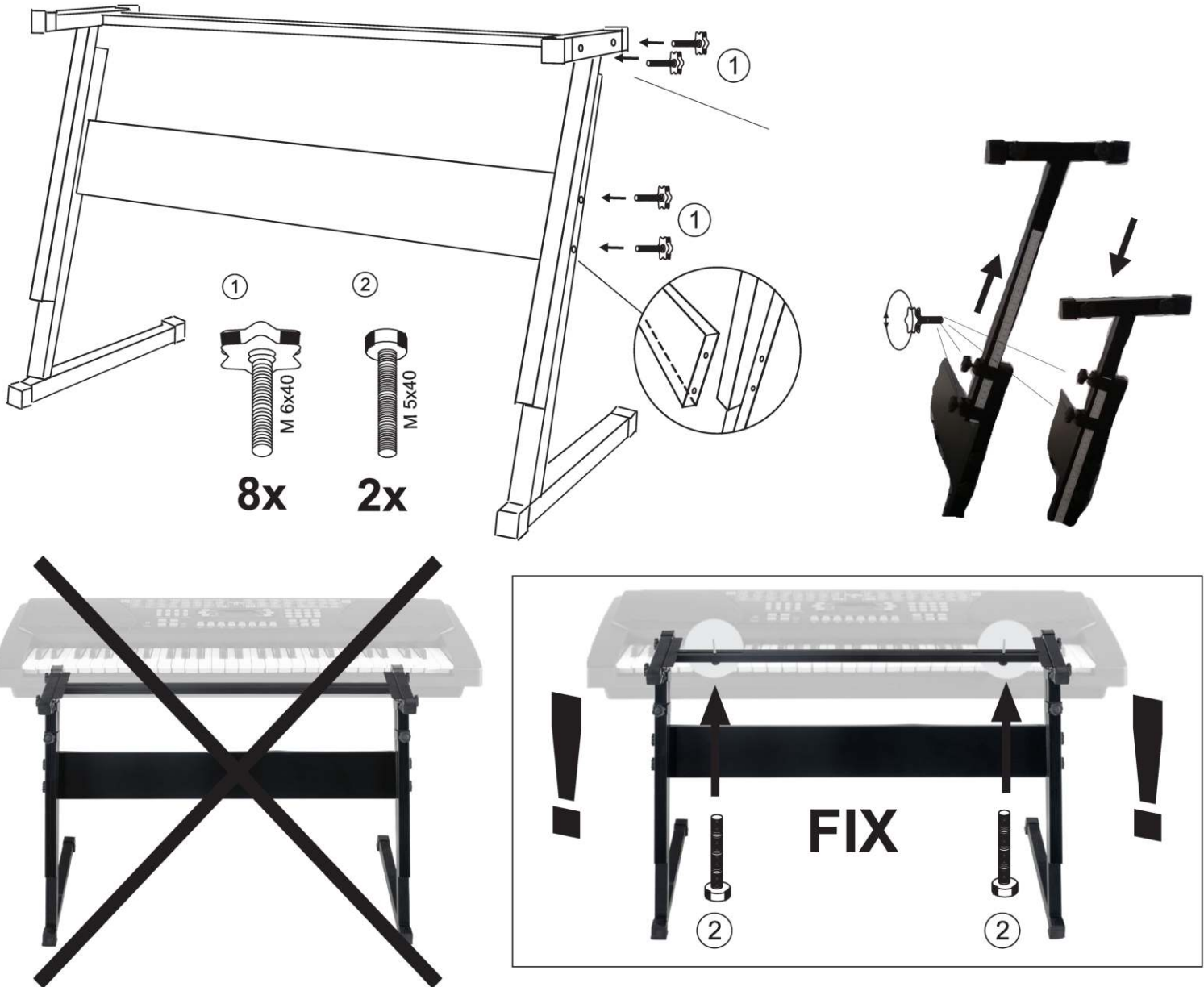

VORSICHTSMASSNAHMEN (BITTE SORGFÄLTIG DURCHLESEN) Kinder sollten beaufsichtigt werden, um sicherzustellen, dass sie dieses Produkt nicht als Spielzeug verwenden. Lassen Sie Kinder niemals unbeaufsichtigt mit dem Verpackungsmaterial spielen. Warnhinweise: Stellen Sie das Produkt stets auf eine geeignete Oberfläche ab, um ein Wackeln oder Umfallen zu verhindern. Vorsichtsmaßnahmen: Um Schäden am Produkt zu vermeiden, stellen Sie es nicht an Plätze mit hohen Temperaturen oder viel Staub, stellen Sie es nicht direkt neben eine Klimaanlage und vermeiden Sie direkte Sonneneinstrahlung. Wenden Sie im Umgang mit dem Produkt keinerlei Gewalt an und stellen Sie keine zu schweren Gegenstände darauf. Ort: Setzen Sie das Produkt nicht den folgenden Bedingungen aus, um Verformungen, Verfärbungen oder größere Schäden zu vermeiden: Direktes Sonnenlicht, extreme Temperatur oder Luftfeuchtigkeit, übermäßig staubiger oder schmutziger Ort, starke Vibrationen oder Stöße. Reinigung: Reinigen Sie das Produkt nur mit einem weichen, trockenen Tuch. Verwenden Sie keine Farbverdünner, Lösungsmittel, Reinigungsflüssigkeiten oder chemisch imprägnierte Wischtücher. Handhabung: Üben Sie keine übermäßige Kraft auf Bedienelemente wie z.B. Schalter, Knöpfe, Tasten aus. Technische Änderungen und Änderungen im Erscheinungsbild sind vorbehalten. Alle Angaben entsprechen dem Stand bei Drucklegung. Für die Richtigkeit und Vollständigkeit der enthaltenen Beschreibungen, Abbildungen und Angaben übernimmt Musikhaus Kirstein GmbH keinerlei Gewähr. Abgebildete Farben und Spezifikationen können geringfügig vom Produkt abweichen. Musikhaus Kirstein GmbH - Produkte sind nur über autorisierte Händler erhältlich. Distributoren und Händler sind keine Handlungsbevollmächtigten von Musikhaus Kirstein GmbH und haben keinerlei Befugnis, die Musikhaus Kirstein GmbH in irgendeiner Weise, sei es ausdrücklich oder durch schlüssiges Handeln, rechtlich zu binden. Diese Bedienungsanleitung ist urheberrechtlich geschützt. Jede Vervielfältigung, bzw. jeder Nachdruck, auch auszugsweise, und jede Wiedergabe der Abbildungen, auch in verändertem Zustand, ist nur mit schriftlicher Zustimmung der Firma Musikhaus Kirstein GmbH gestattet.

PRECAUTIONS (PLEASE READ CAREFULLY) Children should be supervised to ensure that they do not use this product as a toy. Never let children play with the packaging material unsupervised. Warning: Always place the product on a suitable surface to prevent it from wobbling or falling over. Precautions: To avoid damage to the product, do not place it in places with high temperatures or a lot of dust, do not place it directly next to an air conditioner and avoid direct sunlight. Do not use force when handling the product and do not place objects that are too heavy on it. Location Do not expose the product to the following conditions to avoid warping, discoloration, or major damage: direct sunlight, extreme temperature or humidity, excessively dusty or dirty location, strong vibration or shock. Cleaning: Only clean the product with a soft, dry cloth. Do not use paint thinners, solvents, cleaning fluids, or chemically impregnated wipes. Handling: Do not exert excessive force on controls such as Switches, buttons, buttons off. Technical changes and changes in appearance are reserved. All information corresponds to the status at the time of printing. Musikhaus Kirstein GmbH assumes no liability for the correctness and completeness of the descriptions, illustrations and information contained. Shown colors and specifications may differ slightly from the product. Musikhaus Kirstein GmbH - Products are only available through authorized dealers. Distributors and dealers are not authorized representatives of Musikhaus Kirstein GmbH and have no authority to bind Musikhaus Kirstein GmbH legally in any way, be it expressly or through coherent action. This manual is protected by copyright. Any duplication or reprint, even in part, and any reproduction of the images, even in a modified state, is only permitted with the written consent of Musikhaus Kirstein GmbH.