

# Pronomic Laptop Stativ LS-110

Artikel: 00032122

Legen Sie ein Seitenoberteil (1) sowie einen Standfuss (2) übereinander.

Durch die Wahl der Abstandslöcher können Sie hier die resultierende Höhe des Stativs

einstellen. Mit den Rändelschrauben (3) befestigen Sie die Distanzbolzen (4), damit werden

zugleich Seitenoberteil und Standfuss fixiert. Mit den Zusatzdistanzbolzen (5) können Sie die

Gesamtbreite variieren und auf Ihren Laptop anpassen. Führen Sie diesen Schritt für das gegen-

überliegende Oberteil und Standfuss genau so aus. Sie können das Stativ mit den Grundplatten (6) oder

den Klammer (7) für Tischbefestigung verwenden, diese werden mit Schrauben und Beilagscheiben (8)

am Standfuss fixiert. Selbstklebende Gummipads (9) können an den Klammern

oder Grundplatten angebracht werden um die Tischoberfläche vor Verkratzen zu schützen.

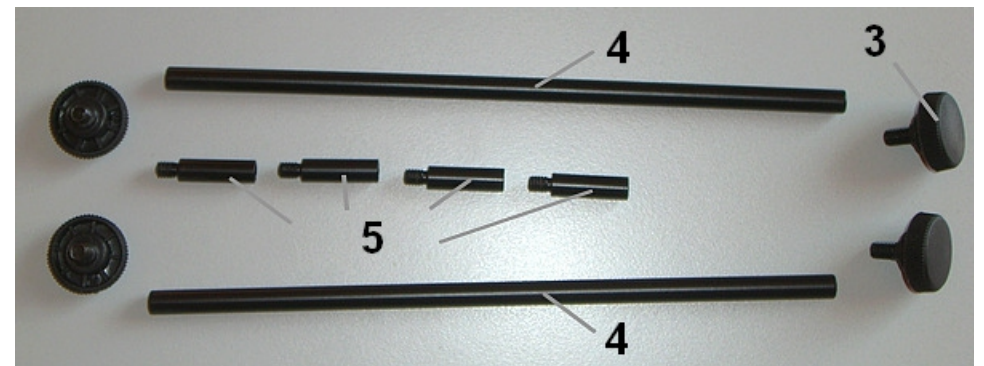
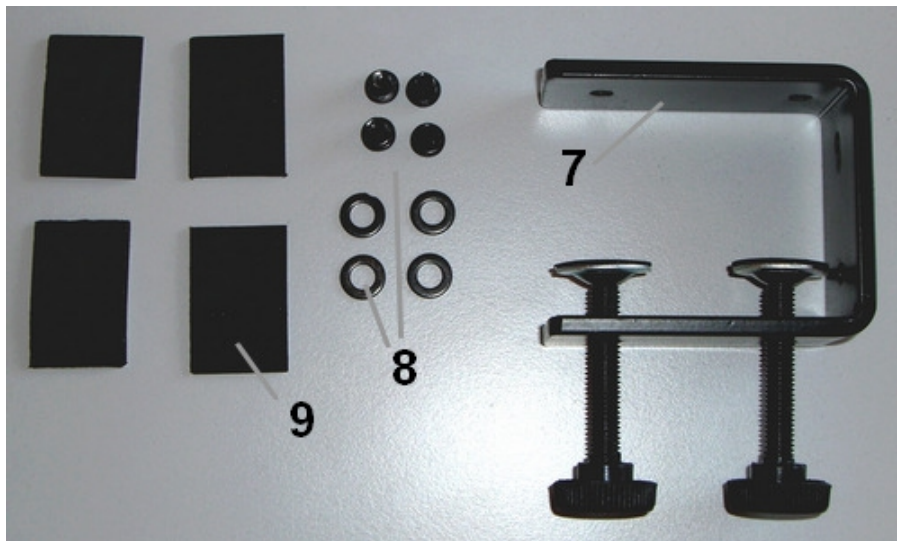
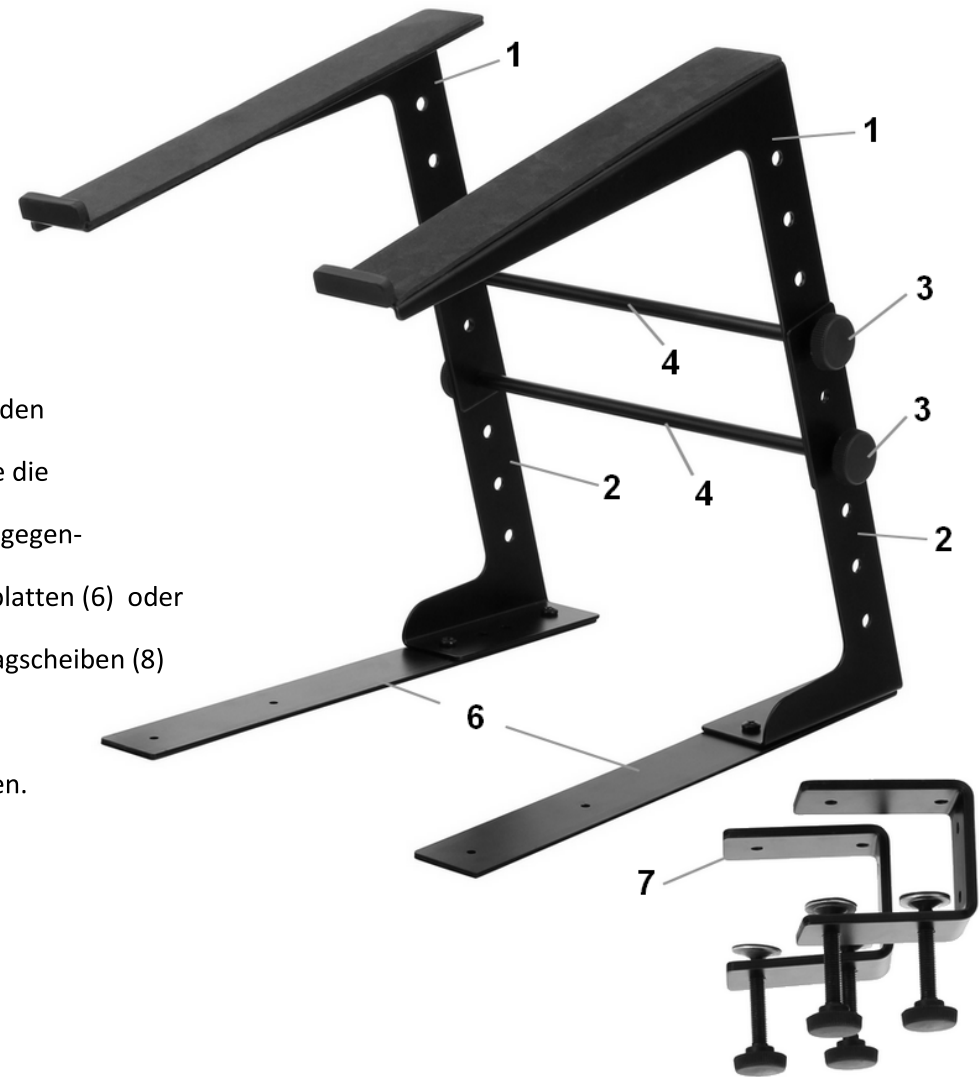

# Pronomic Laptop Stativ LS-110

Artikel: 00032122

Place one top side part (1) and one side leg (2) on top of each other. By choosing the holes you can adjust total height of stand. Fix both parts with screws (3) and distance poles (4). To adjust total width of stand you can use poles (5). Repeat this steps for opposite top part and side leg. You can use the laptop stand with additional ground plates (6) or clamps (7) to fix the stand on a table top.

Fix ground plates or clamp with screws and washers (8) at laptop legs.

You can attach self sticking rubber pads (9) on ground plates or clamps to protect Table surface and avoid scratches.

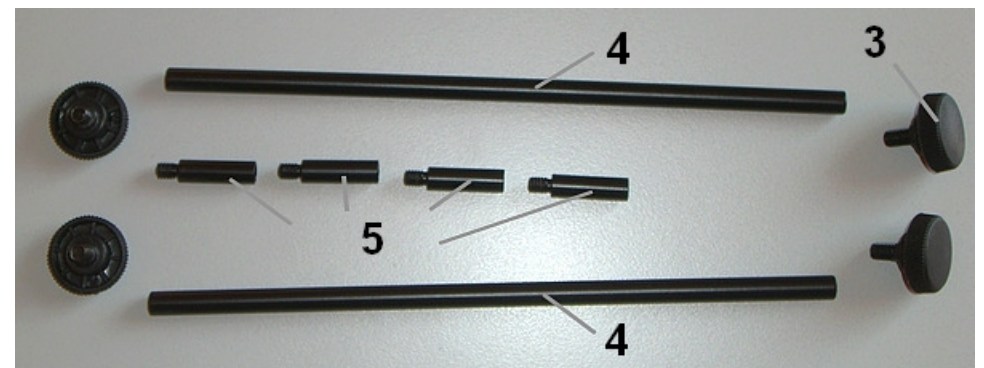
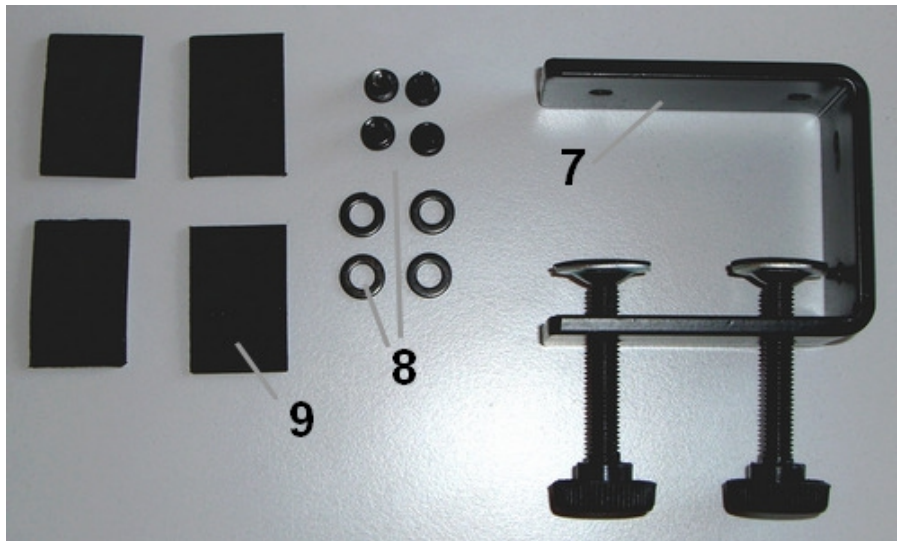
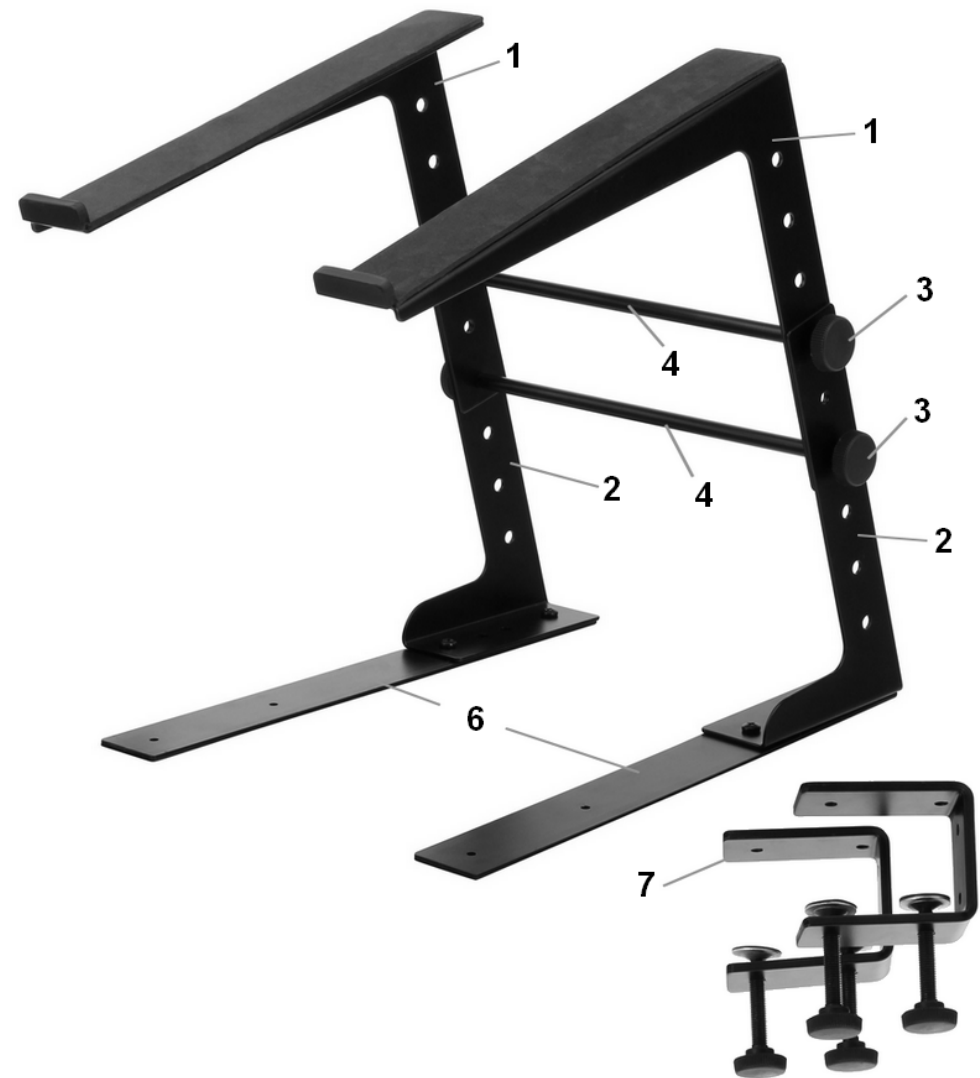



## Classic Cantabile KSD-400Pro MK II

Art. No. 00090607, 00090608, 00090609, 00090610

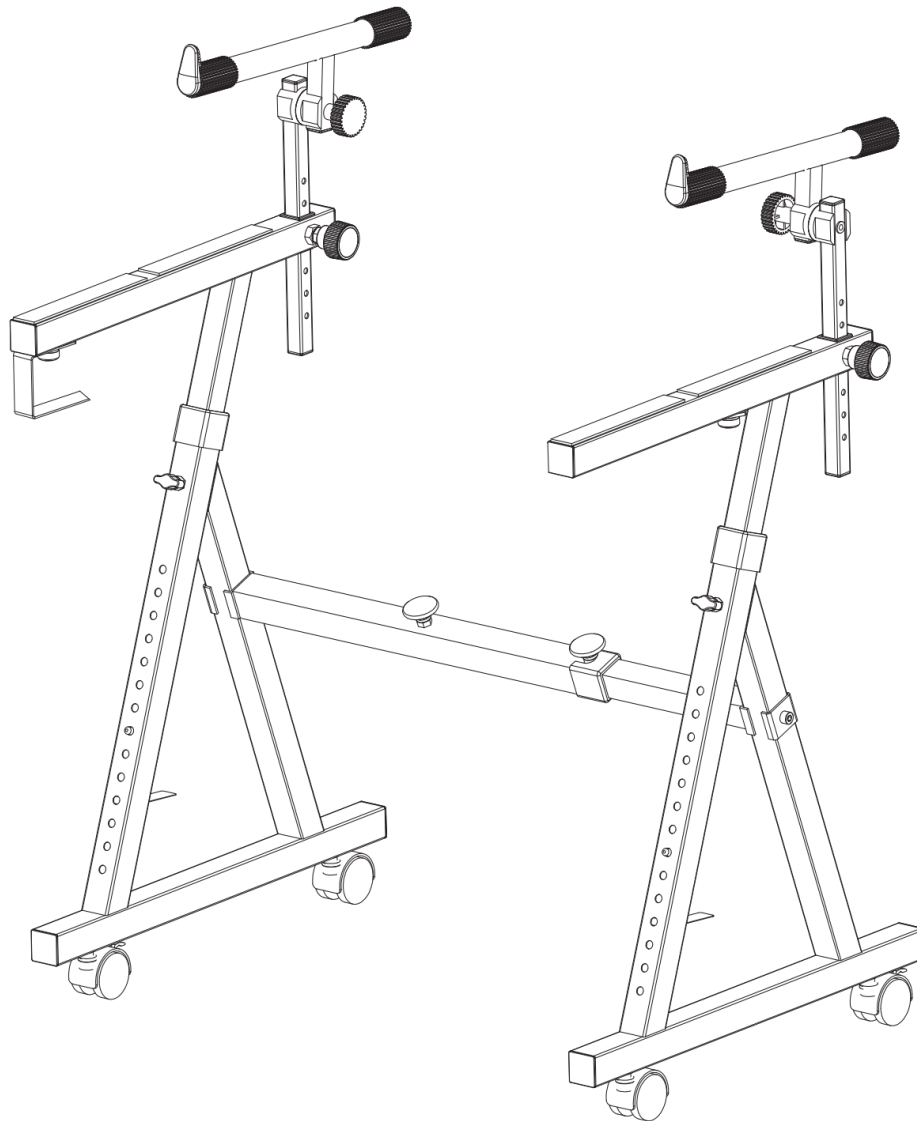

## Assembly instructions

Version 10/2022



---

This operating instruction is protected by copyright. Reproduction of these operating instructions, even in part, is only permitted with the consent of Musikhaus Kirstein GmbH. The same applies to the reproduction or copying of images, even in modified form.

**Content**

**Components**..... 2  
**Assembly**..... 3  
**Specifications**..... 4

## Components

Before assembling the product for the first time, please check that all the necessary components are included.

1. Feet
2. Positioning holder
3. Screw for cross bar
4. Keyboard arm
5. Cross bar
6. Insertion rod for crossbar
7. Headphone holder
8. 2. Tier
9. Allen wrench
10. Rolls

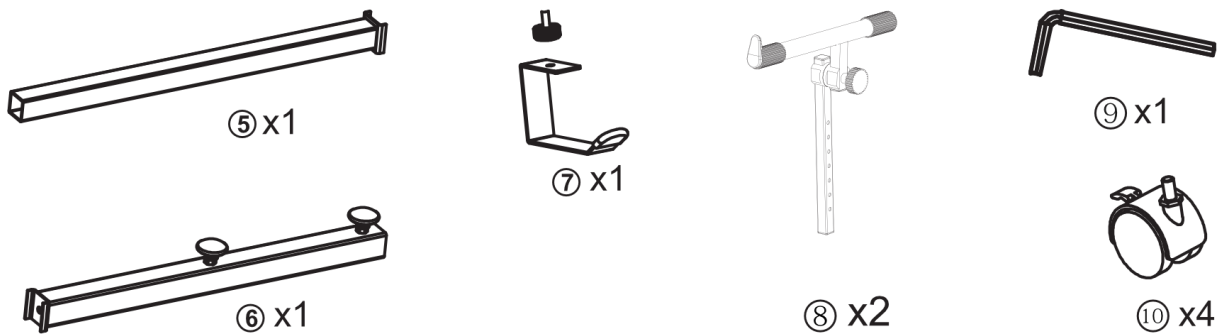
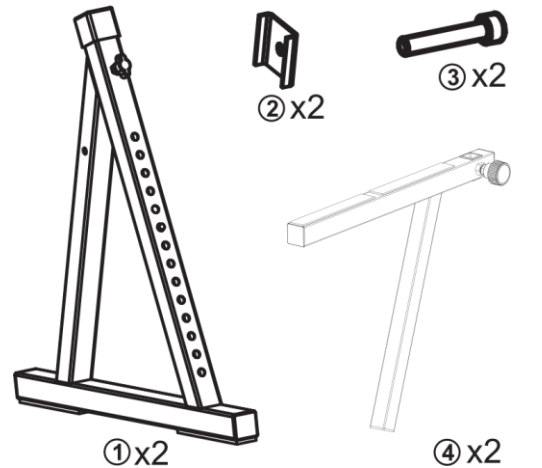

### **IMPORTANT:**

The following components are described and illustrated but are not included with keyboard stand 00090607 and must be purchased separately or in set form.

7. **headphone holder for keyboard stand** - Art. No. 00090610

8. **2. Tier for keyboard stand** - Art. No. 00090609

10. **Rolls for keyboard stand** - Art. No. 00090608

## Assembly

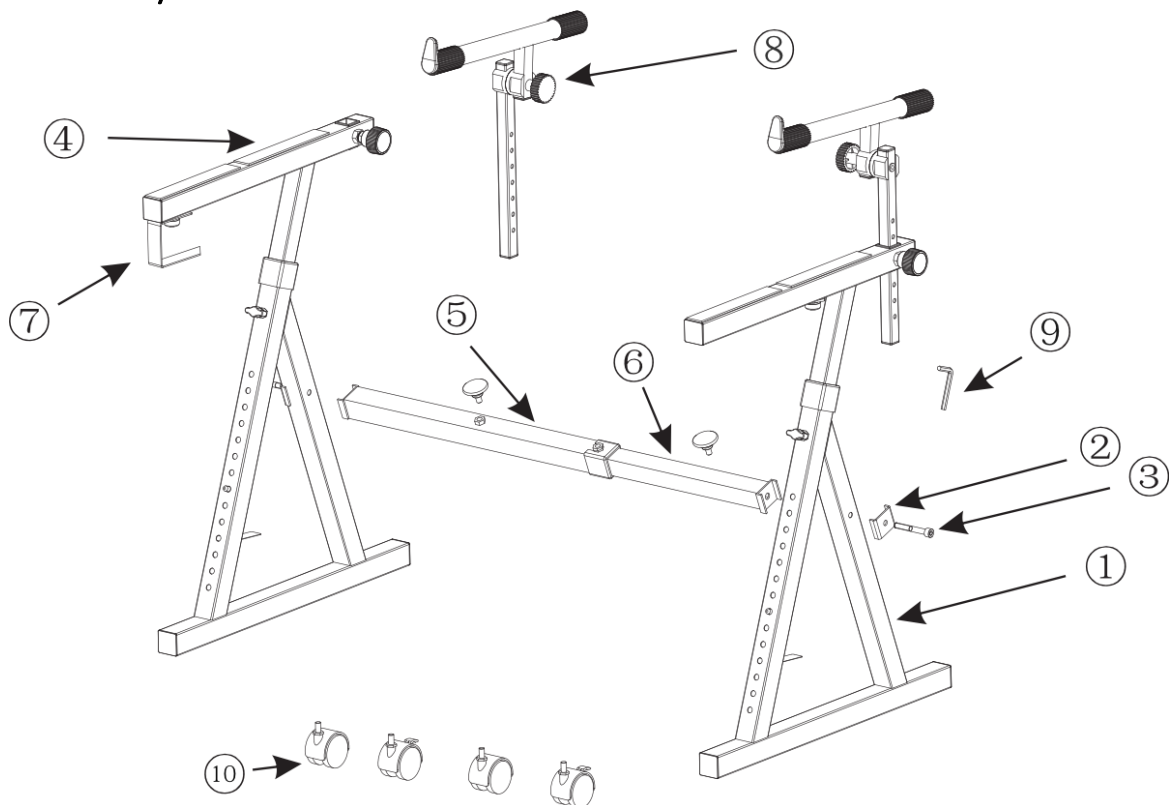

### Structure of the basic construction:

Push the insertion rod **(6)** into the cross bar **(5)** and fix it in the appropriate width with the two screws.

Now attach the insertion rod **(6)** incl. cross bar **(5)** to the feet **(1)** from the outside using the positioning holder **(2)** and the appropriate screws **(3)**.

You can now place the two keyboard arms **(4)** in the feet **(1)** and fix them with the screws that are already mounted on the feet.

### Extended structure:

After you have built up the basic construction, you can extend the stand individually with suitable accessories.

Place the headphone holder **(7)** in the position shown and screw it to the keyboard support **(4)** from below using the appropriate screw.

There are four pre-drilled holes on the underside of the feet **(1)**. The rolls **(10)** can easily be clicked into place with a little pressure.

The second tier **(8)** can be inserted into the keyboard supports **(4)** and fixed at the desired height. Please note the following for this.



- Turn the knob on the keyboard arms **(4)** to the left to release it.
- Then pull the knob
- Now you can adjust the height of the 2. tier up and down.

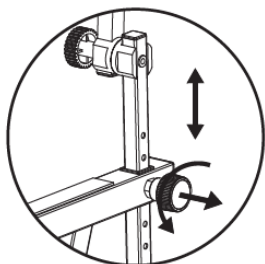

## Specifications

<b>Product type</b>	Keyboard stand
<b>Material - Keyboard stand</b>	Steel
<b>Material - 2nd tier</b>	Steel
<b>Material - Headphone holder</b>	Steel
<b>Material - Rolls</b>	Plastic
<b>Lacquer</b>	Powder coating
<b>Max. Loading capacity - 1. tier</b>	100 kg
<b>Max. Loading capacity – 2. tier</b>	30 kg
<b>Depth – 1. tier</b>	45 cm
<b>Width - Keyboard stand</b>	62,5 cm - 102 cm
<b>Depth - Keyboard stand</b>	50 cm
<b>Height - Keyboard stand</b>	65 cm - 96 cm
<b>Weight - Keyboard stand</b>	7,63 kg
<b>Width - 2. tier</b>	62,5 cm - 102 cm
<b>Depth - 2. tier</b>	34.5 cm
<b>Height - 2. tier</b>	15 cm - 30 cm
<b>Weight - 2. tier</b>	0,65 kg
<b>Diameter - Rolls</b>	5 cm
<b>Weight - Rolls</b>	70 - 76 gram
<b>Max. Loading capacity - Headphone holder</b>	3 kg
<b>Dimensions - Headphone holder</b>	12,7 x 2,6 x 7,0 cm
<b>Weight - Headphone holder</b>	0,11 kg