



Classic Cantabile AP-30 Active Monitor

ArtNo. : 00011178



Operating instructions

Version: 02.2021

© 2021

These operating instructions are protected by copyright. Reproduction of these operating instructions, even in part, is only permitted with the permission of Musikhaus Kirstein GmbH. The same applies to the reproduction or copying of images, even in modified form.

Content

Detailed safety instructions:	2
Using the Active Monitor	3
Controls:	4
Connections:	5
WEEE Declaration (Waste of Electrical and Electronic Equipment)	6

Thank you for purchasing this Classic Cantabile Active Monitor.
To ensure that you are completely satisfied with the item, please read carefully and understand this owner's manual before using our product. Keep these operating instructions in a safe place. The operating instructions must be passed on to all subsequent users.



Follow the operating instructions!



The signal word **WARNING** indicates hazards that can lead to serious injuries if no precautionary measures are taken.



The signal word **NOTE** indicates general precautions to be observed when handling the product.



Images and screen representations in these operating instructions may differ slightly from the appearance of the actual product, as long as this does not have a negative impact on the technical characteristics and safety of the product.



All person-related formulations in these operating instructions are to be regarded as gender-neutral.

These operating instructions apply to persons who have been supervised or instructed in the operation of the appliance by a person responsible for their safety and who have demonstrated their ability to handle the appliance.



**Children should be supervised to ensure that they do not play with the appliance.
Do not leave children unattended.**

All information in these operating instructions has been checked to the best of our knowledge and belief. However, neither the author nor the publisher can be held liable for any damage in connection with the use of these operating instructions.

Other product, brand and company names mentioned in this document may be the trademarks of their respective owners. Compliance with all applicable copyright laws is the responsibility of the user of this document.

Detailed safety instructions:

- Read these instructions.
- Keep these instructions in a safe place.
- Heed all warnings. Follow all instructions.
- Do not use this appliance near water.
- Clean the unit only with a dry cloth.
- Do not block any ventilation openings.
- Do not install near any heat sources such as radiators, heat registers, stoves, or other apparatus that produce heat.
- Do not step on the cable and avoid pinching it, especially at the cable plug, the socket and the cable exit from the appliance.
- Use only stands, tripods, brackets or tables specified by the manufacturer or sold with the unit. Handle with care to avoid injury.
- Pay attention to the volume! Listening at too high a volume level can permanently damage your hearing.
- Disconnect this unit from the power supply during thunderstorms or when not in use for long periods of time.
- Contact qualified service personnel for all repair/maintenance work. Do not open the unit or the housing without authorisation. Servicing is required when the apparatus has been damaged in any way, such as power-supply cord or plug is damaged, liquid has been spilled or objects have fallen into the apparatus, the apparatus has been exposed to rain or moisture, does not operate normally, or has been dropped.

Specifications:

Power supply: AC 120V~, 60 Hz

Power: 40W

Weight: 15kg

Dimensions: 351x345x367mm

Use of the Active Monitor

Installation place

Do not expose your device to the following conditions to avoid deformation, discolouration or more serious damage:

- Direct sunlight
- Too high temperatures (near a heat source or in a car exposed to direct sunlight).
- Humidity

Operation and transport

Do not apply excessive force to the rotary joints, connections or other parts of the box for use.

Always pull the cables out of the socket by the plug and not by pulling on the cable. Disconnect the cables from all sockets before moving the product.

Dropping the unit, bumping it or placing heavy objects on it may result in damage to the unit. In this case, scratches or other more serious damage may also occur.

Electronic noise

This product contains digital circuitry and may occasionally interfere with radio or television equipment if placed too close to it. If such interference occurs, move the speaker further away from the affected equipment.

Cleaning

Clean the instrument with a dry, lint-free cloth. A slightly damp cloth can remove stubborn dirt from the instrument.

Do not use chemical cleaning agents containing alcohol or thinner.

Do not place vinyl objects on the unit.

Switch off the unit before connecting it to the power supply

To avoid damage to your unit and connected instruments, switch off all connected equipment before connecting or disconnecting power.

Energy supply

Switch the "Power" button to "OFF" when you are not using the unit.

Controls:

Front

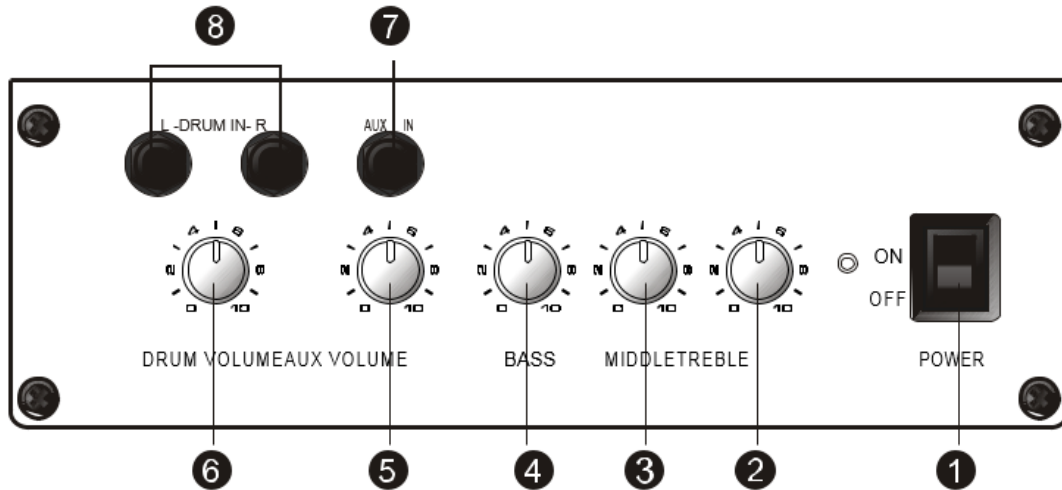

1. "Power" button - Switch the unit on or off
2. "Treble" knob - Allows you to adjust the treble in the mix
3. "Middle" knob - Regulate the mids in the mix
4. "Bass" knob - This can be used to raise or lower the bass in the mix
5. AUX Volume Knob - Use this knob to adjust the output volume of the external audio signal.
6. "Drum Volume" knob - Use this knob to regulate the output volume of the connected instrument.
7. AUX IN socket - input socket for connecting external audio equipment
8. Drum IN socket (left and right) - input socket for digital instruments such as e-drums

Back cover

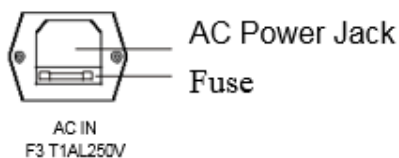

If the power supply does not match the requirements of the amplifier, the electrical fuse may be damaged.

If the amplifier does not operate normally, have this fuse checked.

Connections:

Connecting the power cable



Make sure that the amplifier is switched off while connecting or disconnecting the unit from the power source.



Connect the power cable to the power input socket on the back of the box.

Plug the power cable into the socket.

Connecting the Drum IN socket

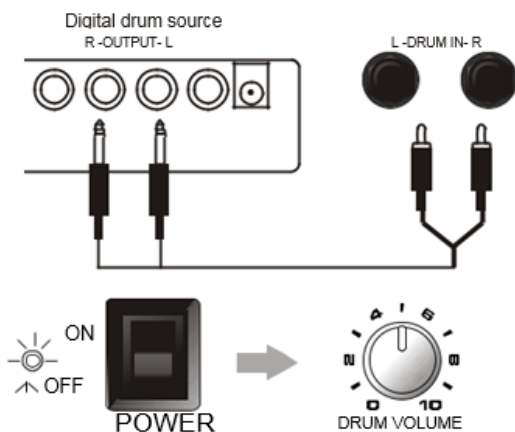

Connect your digital drum set via audio cable to the Drum IN socket of the amplifier while it is switched off.

The volume of the digital drum set can be changed by the "Drum Volume" control.

AUX IN socket

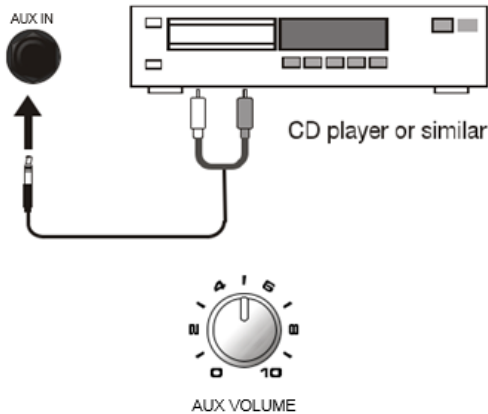

Connect your external audio device (e.g. MP3 player, mobile phone, etc.) to the AUX IN socket to play your favourite songs parallel to the drum kit sound.

The volume of the external audio device can be changed using the AUX volume control.

WEEE Declaration (Waste of Electrical and Electronic Equipment)

Your product has been designed and manufactured using high quality materials and components that are recyclable and reusable. The symbol means that your product must be disposed of separately from household waste at the end of its life. Dispose of this appliance at your local collection point or recycling centre. Please help protect the environment in which we all live.

All technical data and appearances are subject to change without notice. All information was correct at the time of going to press. Musikhaus Kirstein GmbH does not guarantee the accuracy or completeness of the descriptions, photographs or statements contained in this manual. Printed colours and specifications may differ slightly from the product. Musikhaus Kirstein GmbH products are only sold through authorised distributors. Distributors and dealers are not representatives of Musikhaus Kirstein GmbH and are not authorised to legally bind Musikhaus Kirstein GmbH in any way.

 **KIRSTEIN.de**

Musikhaus Kirstein GmbH
Bernbeurener Str. 11
86956 Schongau - Germany
Phone: 0049-8861-909494-0
Fax / Fax: 0049-8861-909494-19



XDrum Schlagzeug Hocker

Aufbauanleitung

Sie finden die Aufbauanleitung zu Ihrem Drum Hocker online unter folgendem Link:

XDrum Semi

https://www.kirstein.de/docs/manuals/XDrum-Schlagzeughocker%20Semi-Aufbauanleitung_DE.pdf



XDrum DHS-1

https://www.kirstein.de/docs/manuals/XDrum-Schlagzeughocker%20DHS-1-Aufbauanleitung_DE.pdf



Um die Umwelt zu schützen, versenden wir diese Handbücher nicht in gedruckter Form. Sollten Sie dies dennoch wünschen, können Sie sich die Anleitungen ganz einfach unter den angegebenen Links bzw. durch Scannen des QR Codes ausdrucken oder Sie kontaktieren uns direkt und wir schicken Ihnen diese in gedruckter Form per Post zu.

XDrum Drum Stool

Assembly instruction

You can find the Assembly instruction for your drum throne online under the following link:

XDrum Semi

https://www.kirstein.de/docs/manuals/XDrum-Drum%20Stool%20Semi-Assembly%20Instruction_EN.pdf



XDrum DHS-1

https://www.kirstein.de/docs/manuals/XDrum-Schlagzeughocker%20DHS-1-Assembly%20Instruction_EN.pdf



In order to protect the environment, we do not send these manuals in printed form. Should you nevertheless wish to do so, you can easily print out the instructions using the links or QR code provided or contact us directly and we will send them to you in printed form by post.



DD-650 Digital Drum

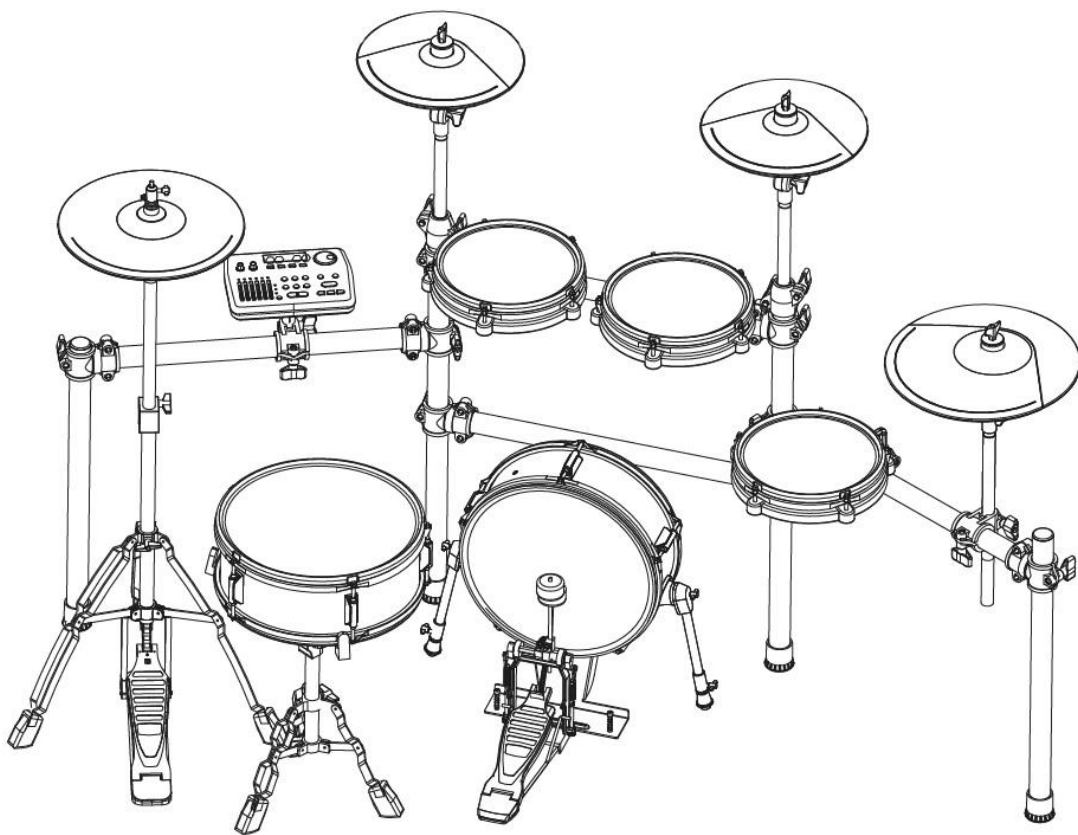

User Manual

ArtNr.: 00056971
Version 07/2020

Thank you for purchasing the DD-650 Digital Drumset.

Please read this manual very carefully to be able to use all the functions of the **DD-650**. We also advise that you store this manual safely for future reference.

Caution!

In order to prevent injuries and damage to the device please make sure you read the safety instructions before using the DD-650 for the first time.

Safety instructions

Please read the manual carefully before using the device and keep it in a safe place. Adhere to the safety instructions to prevent damage or even injuries via electricity, short circuit or fire. The safety instructions are as follows:

Do not remove any part of the casing. There are no parts within the device that need to be maintained by you. If a repair is necessary, please contact a qualified workshop.

- Keep the device away from rain or other kinds of moisture. Do not use the device in moist or wet conditions. Do not place containers filled with liquids on top of the device so that nothing wet can get inside the device.
- Should the cable or the socket be damaged there is the possibility of experiencing sound loss during the use of the digital drums. Should you notice a strange smell or should the device start smoking please turn it off immediately and remove it from the power grid afterwards send it to a qualified workshop.
- Only use a voltage that is accepted for this device. The correct voltage is displayed on the module.
- Before cleaning the device, make sure to remove it from the power grid. Never touch the plug or the socket with wet hands.
- Please check the condition of the plug on a regular basis and remove dirt or dust which might have accumulated on it.

Precautions

- Do not place the device near heat sources such as radiators or stoves or other appliances that generate heat.
- If you want to remove the device from the power grid please always pull at the plug and never at the cable.
- Do not use the digital drum over a power strip as this may lead to a loss of sound as well as an overheating of the socket.
- Disconnect the device before storms or when you are not using it for longer periods of time.
- Before connecting the digital drum to other devices, power down all the devices and turn the volume down to its minimum then turn the devices on.
- Do not use the digital drum in close proximity to TVs, radio devices or speakers to avoid interferences.
- Do not put the digital drum on a floor that has an inclination since it won't stand stable and could fall over.
- Remove all cables before transporting the digital drum.
- If you want to clean the device please use a dry, soft cloth. Do not use petrochemical based polishes or paint thinner or other cleaning liquids or chemically impregnated cloths. Do not place vinyl-based products on top the digital drum, neither plastic nor rubber-based objects. This might change the color of the digital drums.
- Do not sit on the digital drums and do not place heavy objects on top of them.
- Do not use excessive force when pushing the buttons, keys and switches on the device.
- Keep a distance of at least 10cm to the nearest wall with the digital drum.
- Read the chapter about the installation and the operation carefully since you might get injured or damage the device if the digital drum is not set up properly.
- Turn the device off during a thunderstorm and remove it from the power grid.

Information for your Security

Please read this section carefully before you use the instrument. Please keep this manual for future reference.

Power Supply

Please connect the included power adapter to a socket with the correct voltage. Do not connect the device with a socket that is not suited for the device. Remove the power adapter from the power grid when you are not using the instrument or during a thunderstorm.

Connections

Before connecting the instrument with other devices, please power down all devices first. This will ensure that the devices won't get damaged and malfunctions are avoided.

Surroundings

Please do not expose the device to the following conditions in order to avoid deformation, decoloring or serious damage:

- Direct sunlight
- extreme temperatures
- extreme humidity
- Dust or dirt
- strong vibrations or tremors
- magnetic fields

Interferences

If radio or television devices are in close proximity to your instrument there may be interferences. In this case, increase the distance to these devices.

Cleaning

Please only clean the instrument with a dry soft cloth.
Do not use paint thinner or petrochemical based polishes.

Handling

Do not use excessive force when operating the buttons and switches. Please make sure that no paper, metal or other objects can get into the instrument. Should this happen, remove the device from the power supply immediately and take it to your specialized retailer for inspection. Always remove all the cables prior to moving the instrument.

Opening the Device

The device may only be opened for repair reasons by authorized service personnel. Address a qualified workshop or the vendor from which you bought the device.

Content	
Installation	5
Sound Module	12
Control panel.....	12
Connections	15
Pads	16
Basic Operation	19
Selecting a Kit.....	19
Modifying a Kit.....	19
Demo Song abspielen	20
Recording a Track	20
Restoring Factory Settings	21
Setup.....	21
Backvolume.....	21
MIDI-Funktion.....	21
Advanced Settings.....	21
Sensitivity.....	21
Headroom.....	21
Sense Time.....	22
Trigger Curve.....	22
Cross Talk.....	22
Note Send.....	22
Rim Velocity.....	22
Pedal Velocity.....	22
Calibration.....	22
Split Point.....	22
Chick Time.....	23
Splash Time.....	23
Peak Decay.....	23
Rim Modifier.....	23
Open Point.....	23
Close Point.....	23
Appendix	24
List of Included Kits.....	24
Pattern List.....	24
Voice List	25
Specifications	30

Installation

This image shows the completely assembled drumkit after installation (power connector and wire connections are not shown).

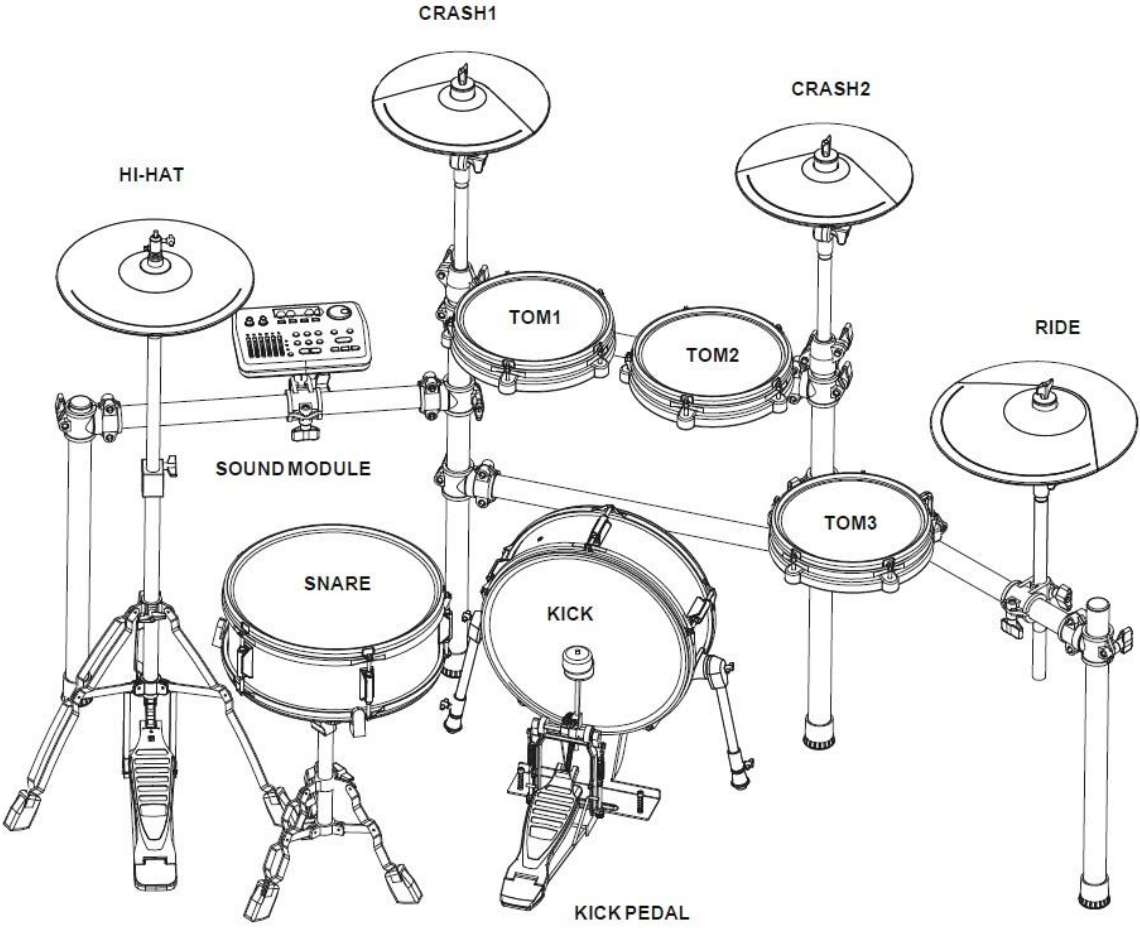

Rack Installation

Rack components

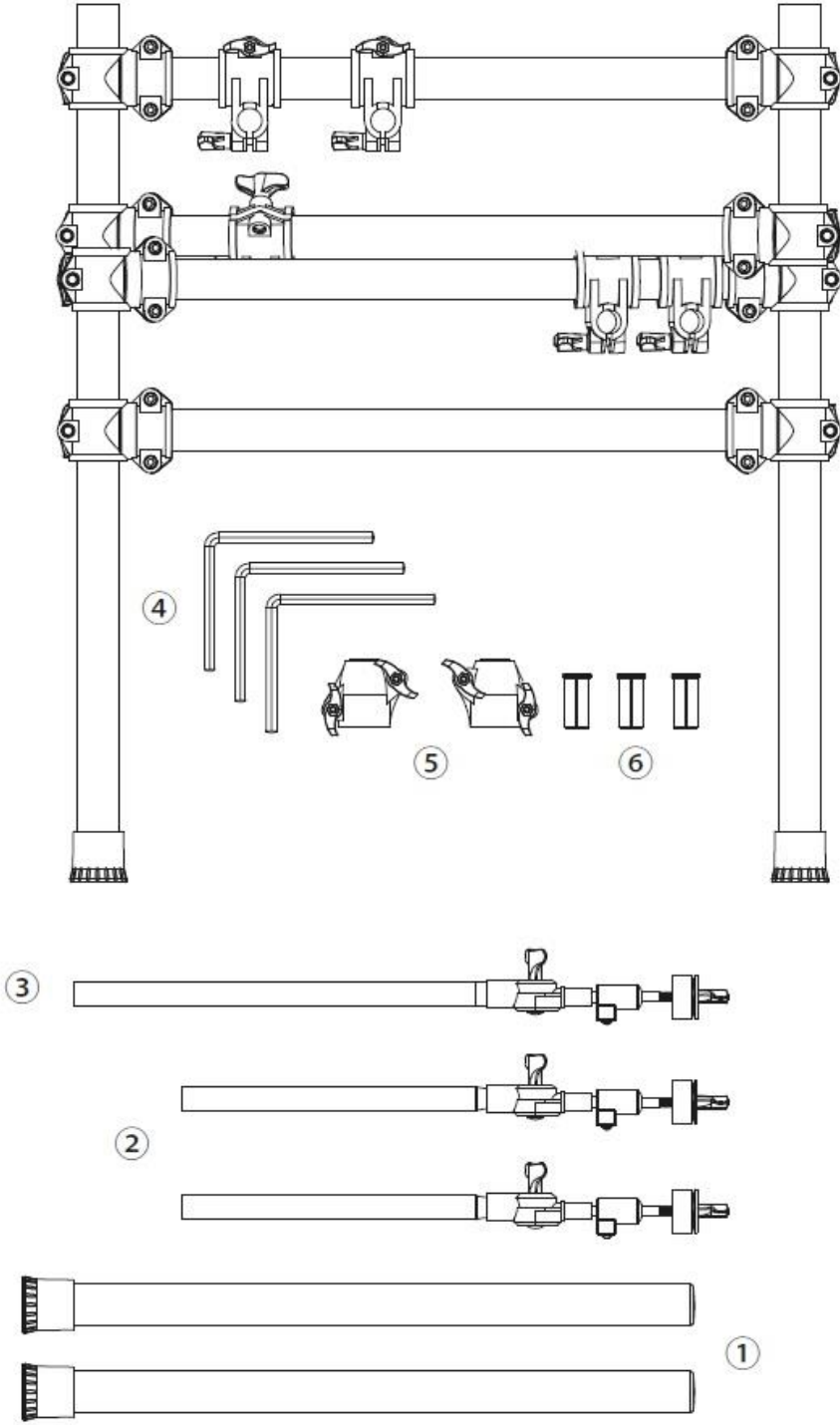

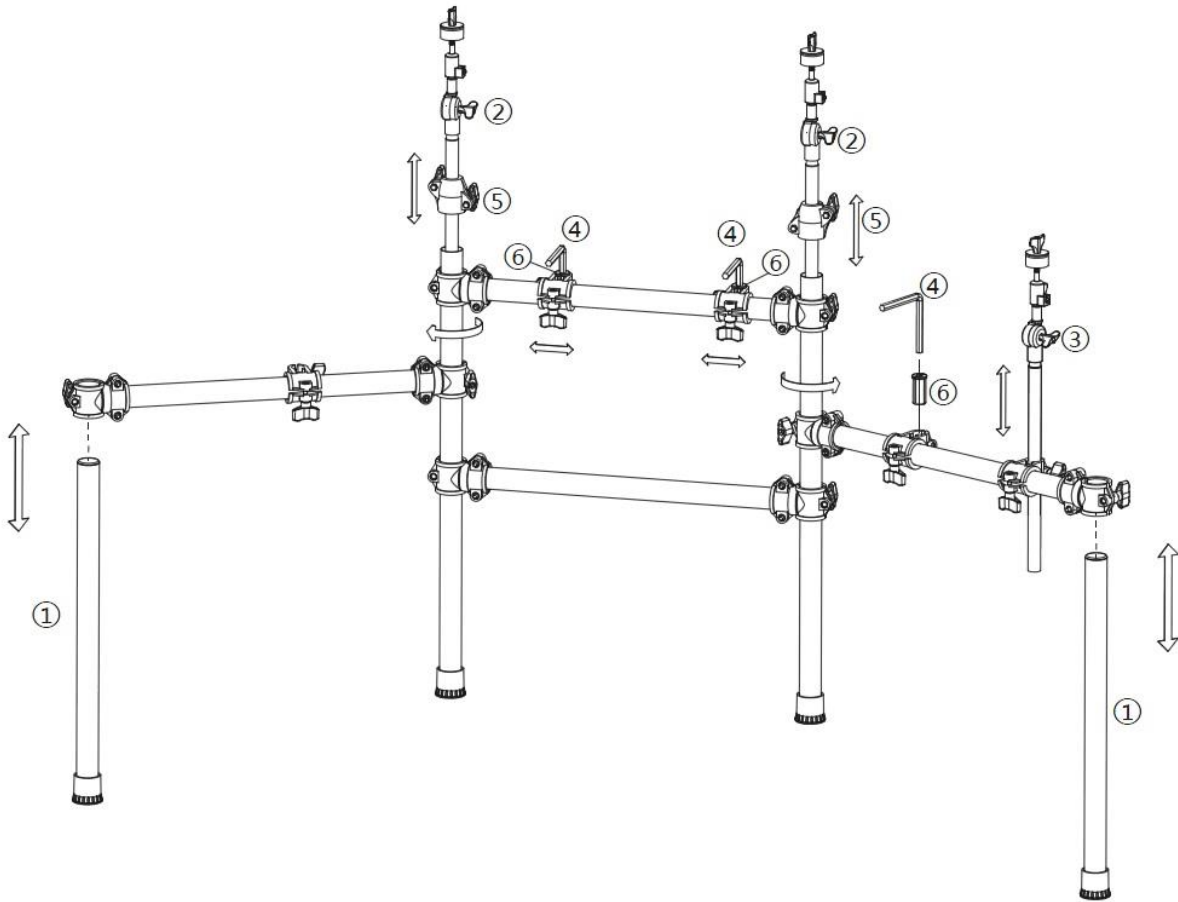

1. Stretch the drum rack according to the picture and install both legs (1). Make sure the drum rack stands upright and then fasten the wing nuts.
2. Install the crash connector clamps on the middle legs (5). Afterwards insert the crash stands to their clamps. Finally fasten their wing nuts (2).
3. Fix the ride stand to its clamp and fasten the wing nut (3).
4. Fasten the hex rod sleeves (6) to the tom clamps and then insert the tom hex rod (4) into them.

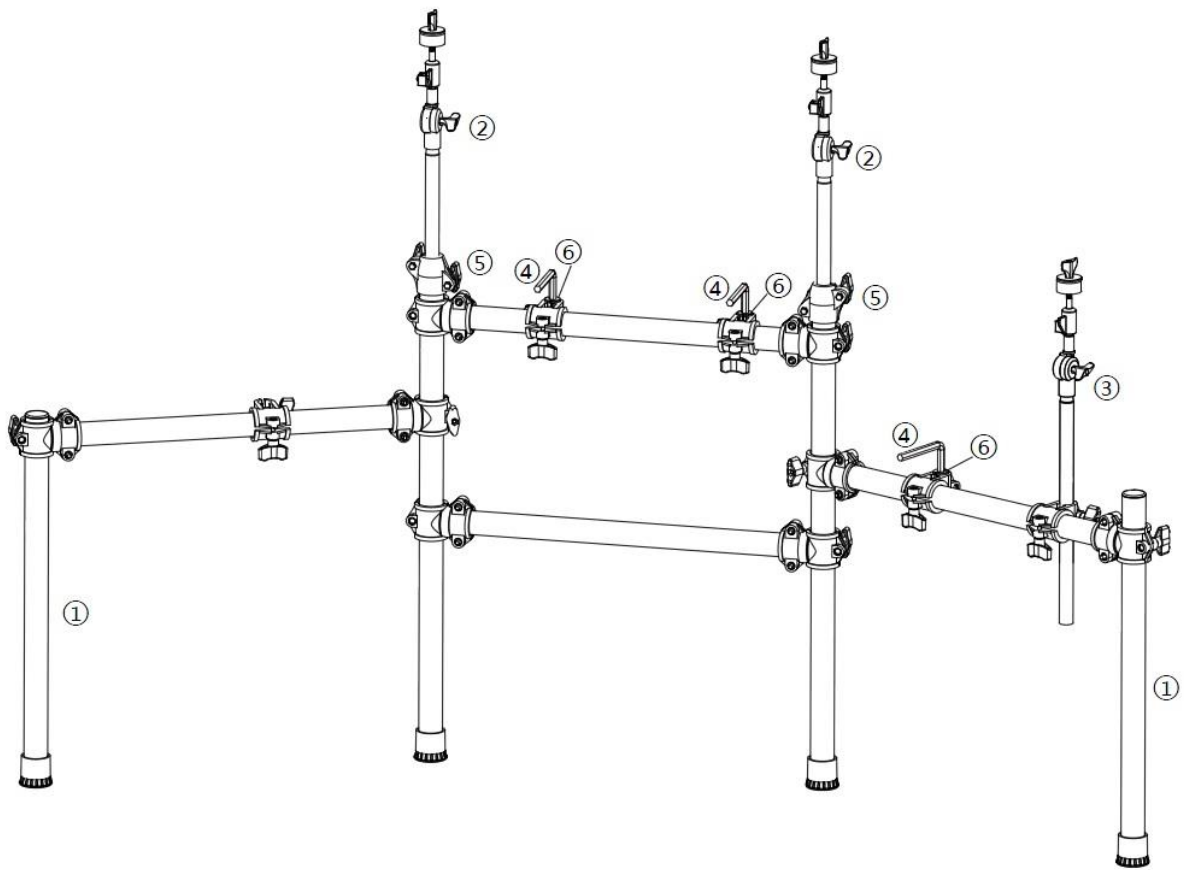

5. Check the drum rack again to see if all positions are suitable for playing and all parts are securely fastened to avoid injuries in case a component falls off.

The image above shows how the rack should look after the installation is finished. Please refer to the following pages for the installation of the drum pads.

HiHat Installation

1. Open the HiHat stand legs (1) and make it stand firm.
2. Insert the thin rod (2) into the screw thread at the bottom of the stand.
3. Place the hollow rod (3) over the thinner rod (2).
4. Place the HiHat Cymbal tray (4) on the thin rod (2) and fix it onto the structure.
5. Adjust the hollow rod to a suitable height and fasten it. Put the HiHat (5) on the tray (4).
6. The screw on top of the HiHat allows the control of space between the tray and the HiHat. Make sure there is enough space between the two of them.

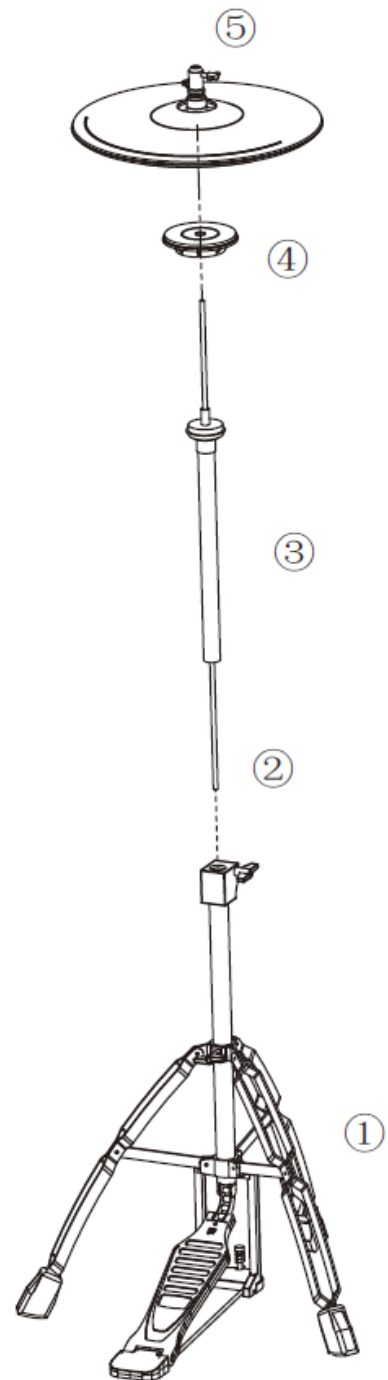
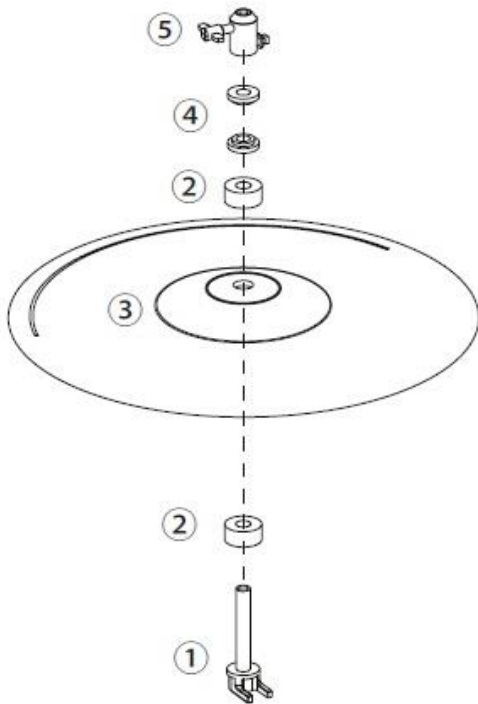

HiHat Installation

1. Insert the felt (2) on the base (1), align the socket on the base to the stopper underneath the cymbal and afterwards fix the HiHat (3) on it.
2. Put another felt (2) on top of the HiHat and fixate it with the round nut as shown in the image above (4).
3. Fix the head (5) to the base.

Snare Installation

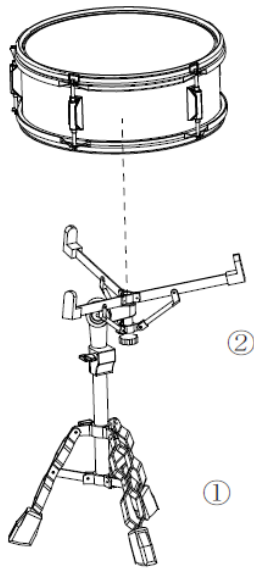

1. Open the Snare stand legs (1) to a suitable position and make it stand firm.
2. Open the Snare stand arms (2) and put the Snare upward on the stand.
3. Tighten the Snare stand arms by rotating the rotary on the bottom side.

Cymbal Installation

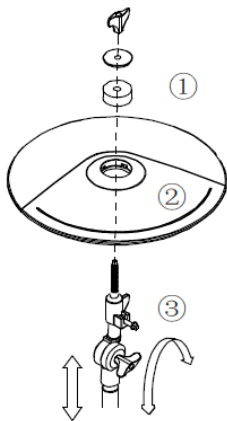

1. Remove the wing nut, washer and felt (1) from the top of the rod.
2. Put the cymbal pad (2) into the rod (3) and then reattach the components removed in step one. Fasten the wing nut but not too tightly. This allows the cymbal to wobble like a real acoustic cymbal.

Tom Tom Installation

1. Loosen the wing nut under the drum pad (2) and insert the hex rod.
2. Adjust the drum pad to a suitable position and refasten the wing nut.

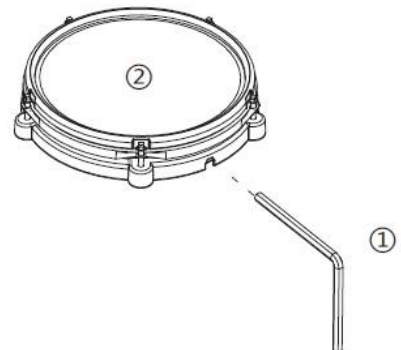

Kick Installation

1. Install the kick legs (1) on both sides and fasten the wing nuts.
2. Place the kick pedal (2) on the kick drum (1). Adjust the pedal in a suitable position and fasten the wing nuts afterwards.

Note: Do not place the pedal too close to the kick to avoid the pedal chain from touching the metal frame of the kick. This would cause a false trigger of the kick.

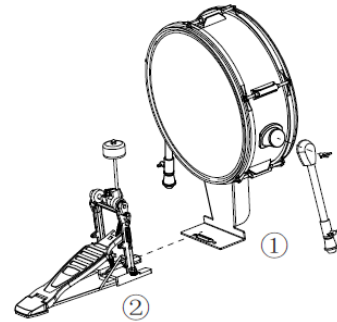

Sound Module Installation

1. Align the holes of the module mount and the sound module, put screws through the holes and fasten them.
2. Insert the rod of the module mount into the clamp then tighten the wing nut.

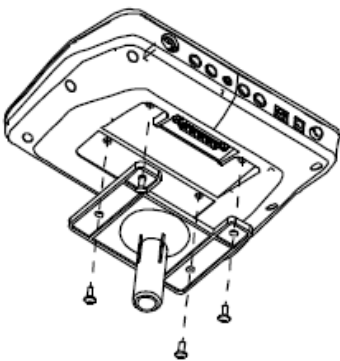

Sound Module

Control panel

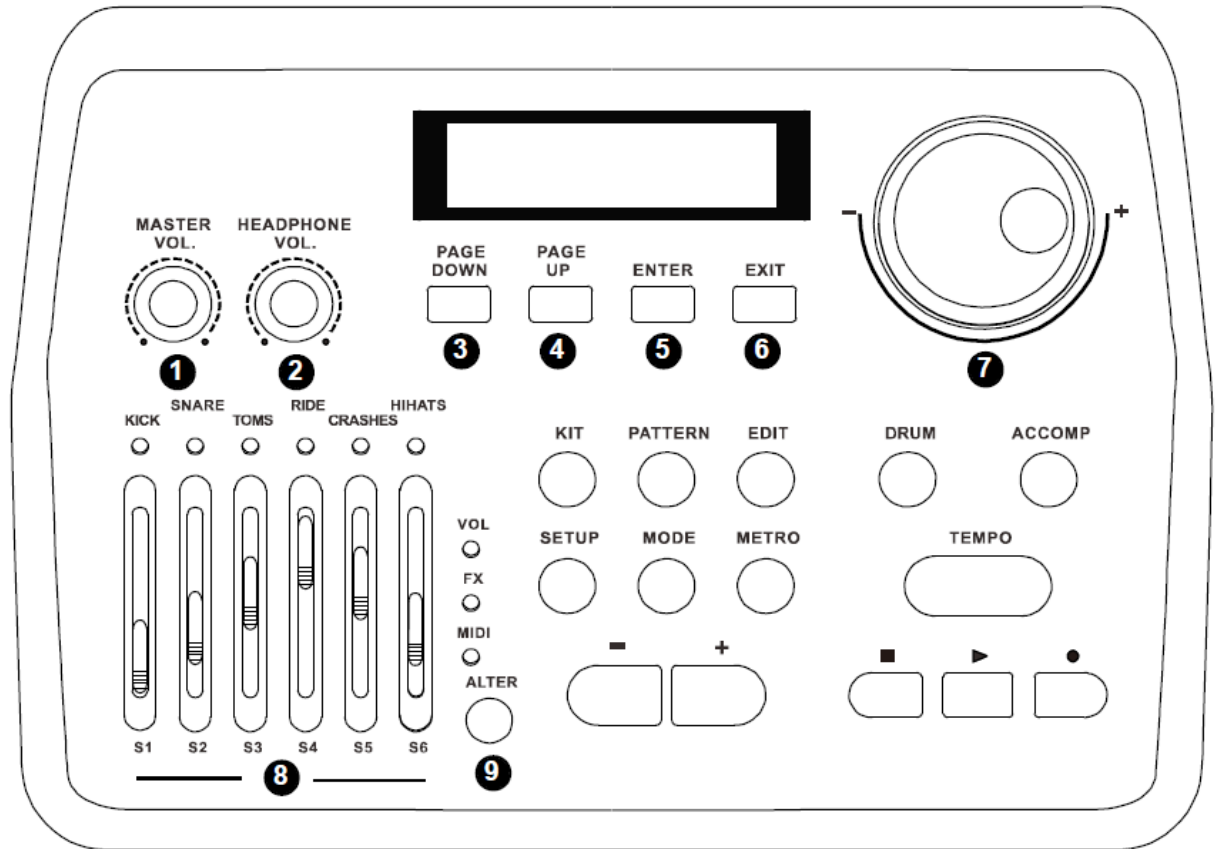

1. **Master Vol.:** Adjust the output level, rotate it clockwise to increase volume.
2. **Headphone Vol.:** Adjust the headphone output level, rotate it clockwise to increase volume.
3. **Page Down:** Switch to the next option in the current menu.
4. **Page Up:** Switch to the last option in the current menu.
5. **Enter:** Proceed to the next submenu or confirm operation.
6. **Exit:** Proceed to the root menu or cancel operation.
7. **Scrolling Wheel:** Turn this wheel to increase or decrease values or change kits quickly.
8. **Mixer:** Change the values of 3 different fader-modes
9. **Alter:** Use ALTER to switch between the fader modes:

VOL-Fader: change the volume of the drums and cymbals (S1-S6).

FX-Fader: S1 controls the reverb level of the kit.

S2 controls the compression rate.

S3-S6 controls the gain of a 4-band equalizer.

MIDI-Fader: S1-S6 are assigned to six different Midi-Controllers.

Controller numbers can be set in the midi-set menu.

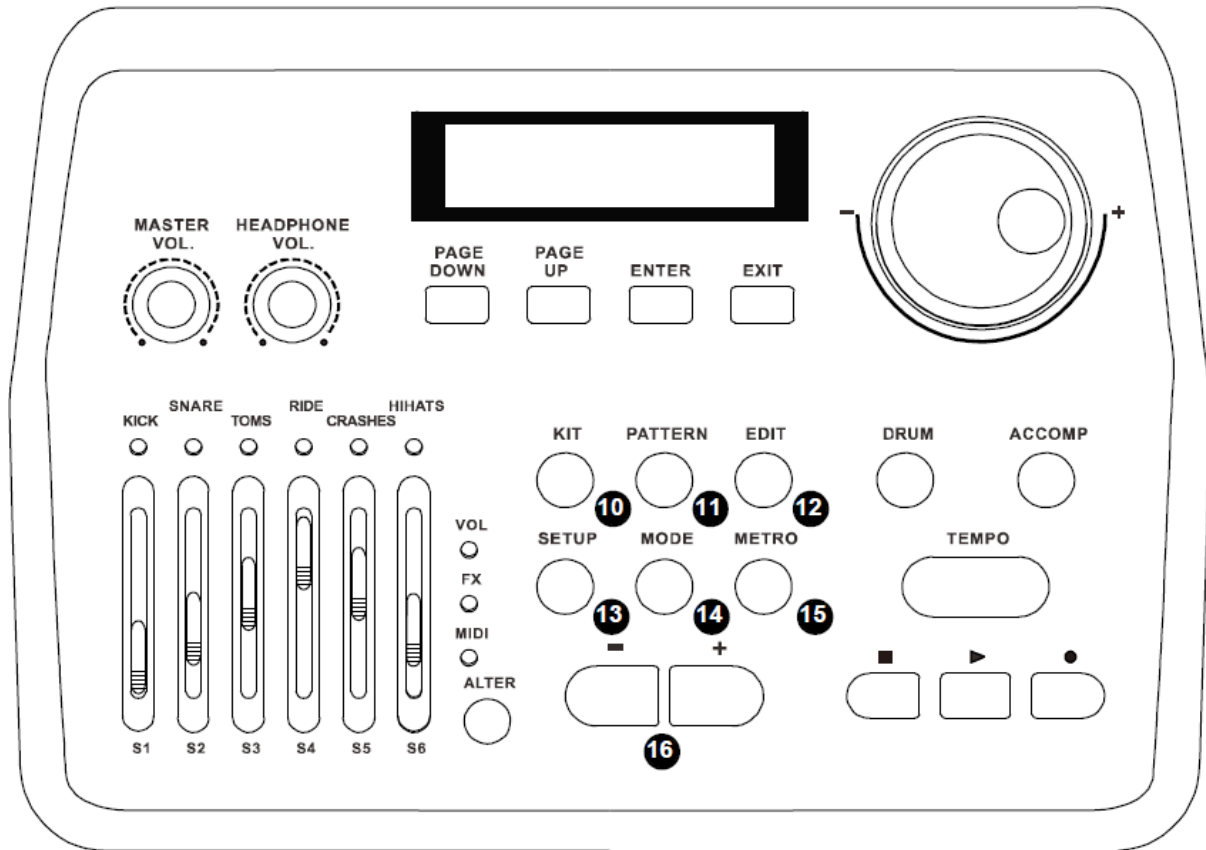

- 10. **KIT:** Press this button to engage in „Kit“mode.
- 11. **PATTERN:** Press this button to engage in „Pattern“mode.
- 12. **EDIT:** To edit the current drum kit, including voice type, voice, volume, reverb, level, pitch and pan.
- 13. **SETUP:** Press this button to adjust system settings.
- 14. **MODE:** Change playing modes for demo patterns.
- 15. **METRO:** Press this button to set the metronome on/off.
- 16. **[-] / [+]:** Use these two buttons to increase/decrease values and settings.
Also, you can use these buttons to select a kit.

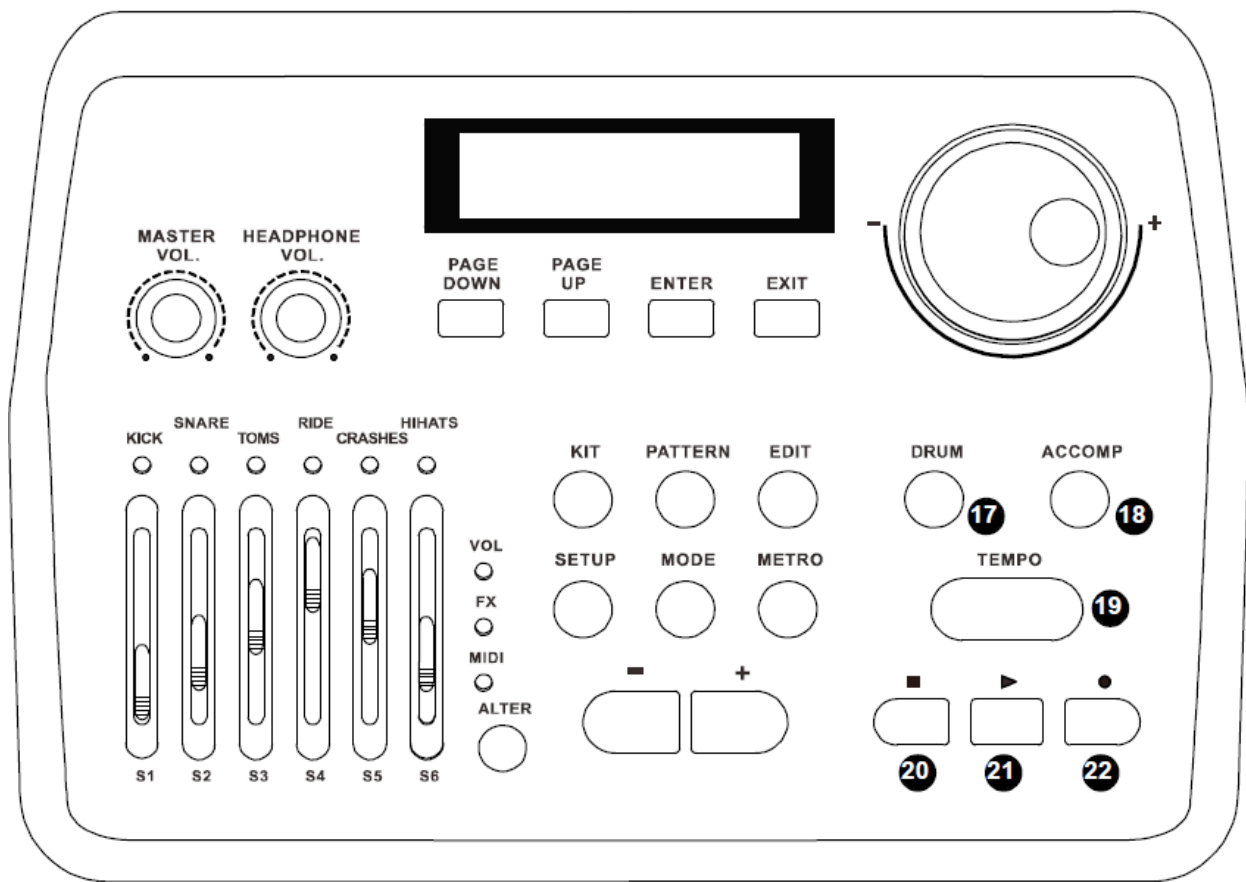

- 17. **DRUM:** Press this button to mute the drum track of a demo pattern.
- 18. **ACCOMP:** Press this button to mute accompaniment tracks of a demo pattern.
- 19. **TEMPO:** Tap this button at a desired rate to get a new tempo for a demo pattern and metronome after you have tapped it four times. You can also use the scrolling wheel to change the tempo after you have pressed the button.
- 20. Pauses playback of the current demo pattern, press it again to cancel playing the current pattern.
- 21. Plays the current demo pattern.
- 22. Press this button to record a drum sequence.

Connections

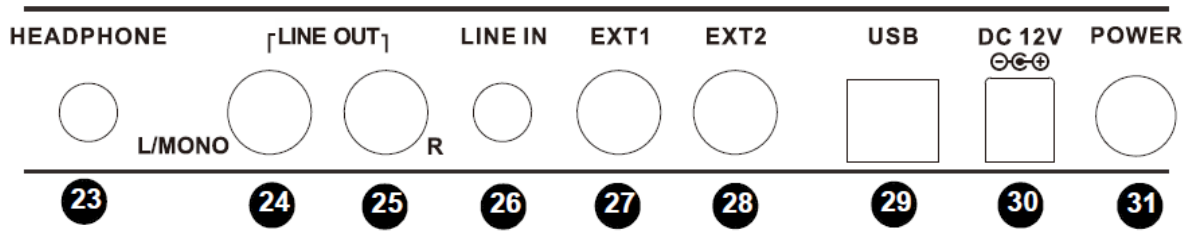

- 23. **HEADPHONE:** Connect your headphones here.
- 24. **MONO LINE OUT L:** Left channel of main output. Connect this output to any amplifier using 1/4"TS cable. For mono output please connect via this socket only.
- 25. **STEREO LINE OUT R:** Right channel main output. Connect this output to any amplifier using 1/4"TS cable. For stereo output please connect both Line out right and left.
- 26. **LINE IN:** Analog input socket of the sound module. You can connect any sound source (iPod, CD-player, mobile phone or computer) to the sound module.
- 27. **EXT1:** Extended trigger socket one, connected to the fourth tom pad by default.
- 28. **EXT2:** Extended trigger socket two, connected to the second crash pad by default.
- 29. **USB:** Connect standard B type USB cables to this socket for updating firmware, gaming, recording midi and using plug-ins for more sound on the computer.
- 30. **DC 12V:** Connect the attached DC 12 V power adapter to this socket.
- 31. **POWER:** Turns the module on and off.

Trigger Inputs

The trigger inputs socket is located at the bottom of the sound module. Connect the multi-trigger connector (aka 25pin connector) to this socket and lock it.

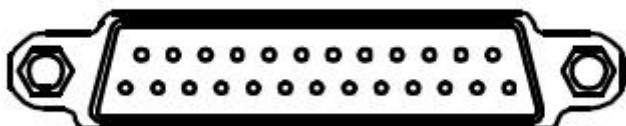

Pads

Playing Pads

All pads are with a velocity response feature. Strike the pad harder to create a higher volume and strike the pad softer to create a lower volume.

Playing Tom Drums

Strike the central position (head) of the pad to make head sound, strike the rim of the pad to make rim sound.

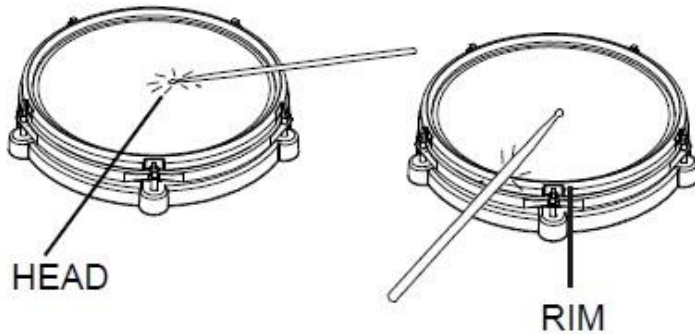

Playing Cymbals

Strike the central position (bow) of the cymbal to make cymbal bow sound, strike the edge of the cymbal to make edge shot sound.

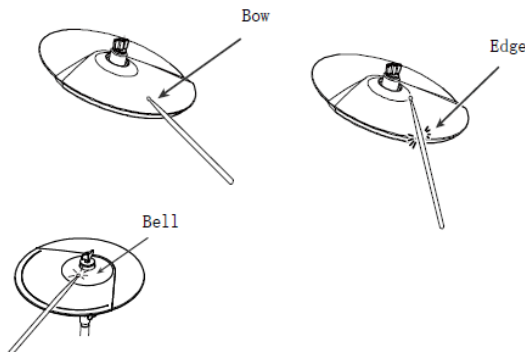

Cymbal Choke

Strike a cymbal, its sound will sustain. Then squeeze the edge portion to mute the sound. Please note that the choke feature is only available on those cymbals marked with 'Choke' on the surface or in the specifications.

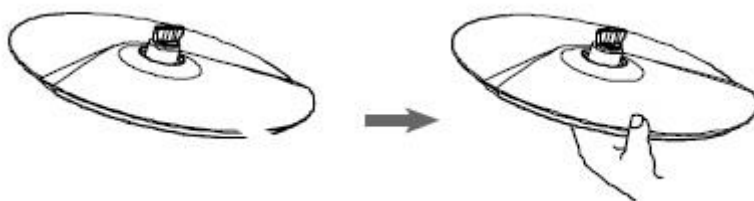

Playing Snare Drum

Strike the central position (head) of the pad to make head sound, strike the rim of the pad to make rim sound. The rim triggering is velocity layered.

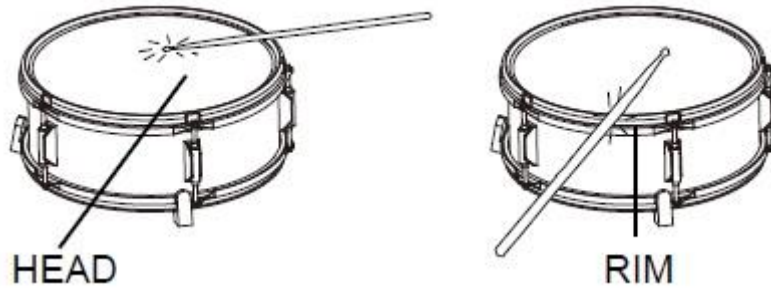

Playing HiHat

1. Strike the HiHat pad without pressing the HiHat pedal to create an open HiHat sound.
2. Strike the HiHat pad while fully pressing the HiHat pedal to create a closed HiHat sound.
3. In certain positions while you press the HiHat pedal, playing the HiHat will trigger a half-open sound.
4. Press the HiHat pedal down quickly to create the HiHat pedal chick sound.
5. Press and release the HiHat pedal very quickly to create the HiHat foot splash sound.

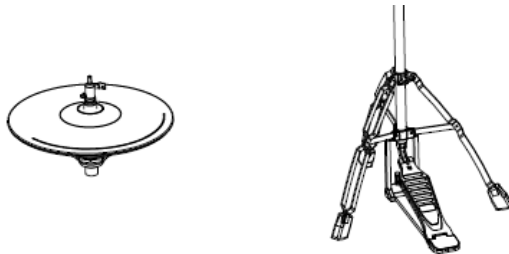

Playing Kick Drum

Press the Kick drum pedal to make kick drum sound.

Before Playing the First Time

Make sure the drum kit is stable and all parts are securely fastened and locked.

- Connect all the cables to the drum module according to their tags.
- Connect the multi-trigger connector to its socket at the bottom of the sound module.
- Connect the power adapter with the device and a socket.
- Power up the sound module.
- Press setup.
- Press PAGE DOWN/UP until you see ADVANCE and confirm with ENTER.
- Press PAGE DOWN until you see Xtalk and then press ENTER.
- Now you can test the functionality of each drum pad with striking it. Strike the drum pad until it says „Ok“ on the screen.
- Press EXIT. In the following SAVE SETUPS screen choose YES.

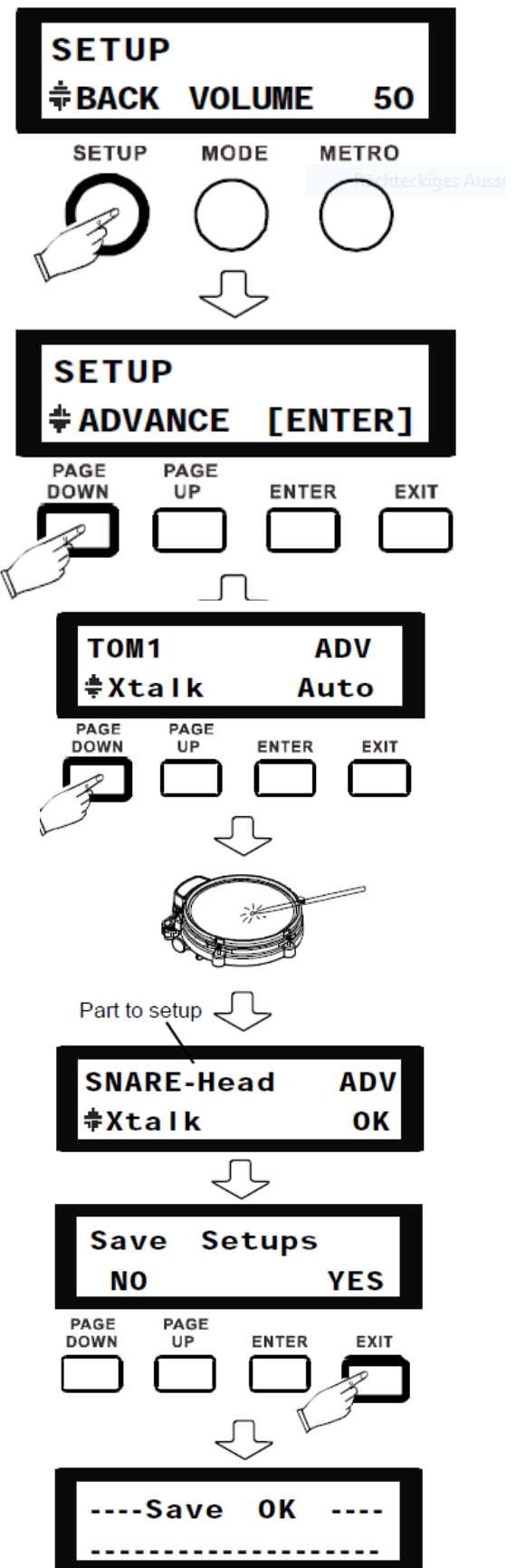

Basic Operation

Selecting a Kit

- Press KIT and use the scrolling wheel to select the desired kit.

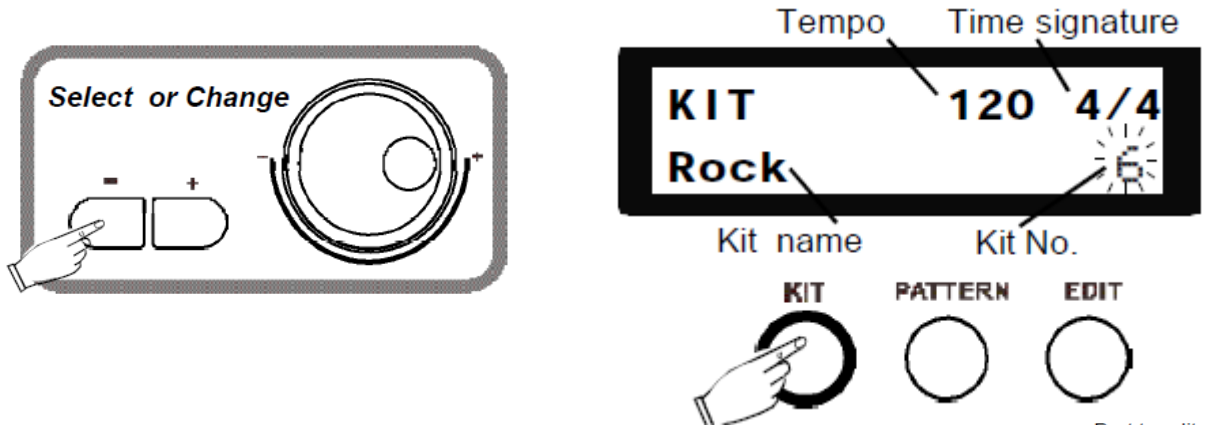

Modifying a Kit

1. Open an existing drum kit and switch into the editing mode via pressing EDIT.
2. Strike the pad (Trigger) on which you would like to program a certain sound or repeatedly press DRUM until the desired pad is shown on the display. For pads that have more than one assigned sound choose the specific trigger for the desired sound.
3. Use PAGE DOWN, respectively PAGE UP, to adjust the menus on the shown images and use the scrolling wheel [-] / [+] or the buttons [-] / [+] to change the settings for the activated trigger.
4. Leave the menu via pressing EXIT.
 - Choose a saving spot for your modifications in the following dialogue with [-] / [+]. Existing data may be overwritten.
5. Confirm the save with ENTER or cancel it with EXIT.

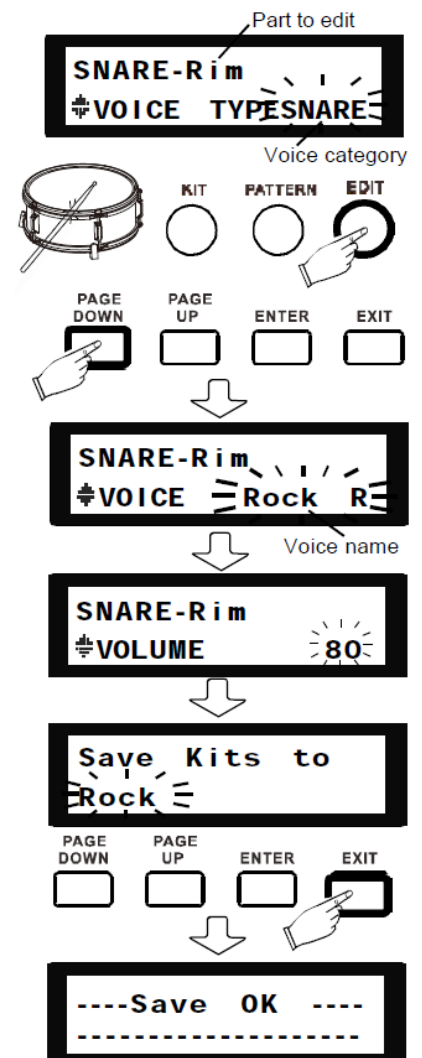

Playing Demo Songs

1. Press the PATTERN button and use the scrolling wheel to choose a song. Afterwards press PLAY and STOP to start or stop the track from playing.

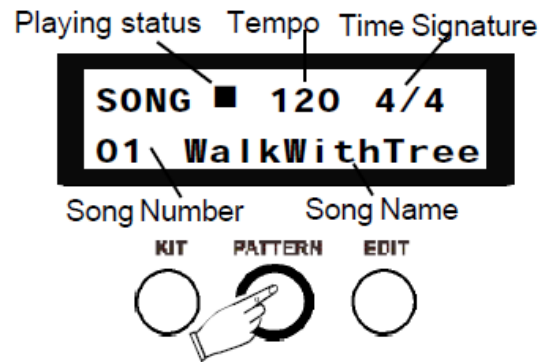

Recording a Track

The drum module offers the opportunity to record up to 15 drum tracks in the operation modes „Kit“ or „Pattern“. This can be done as follows:

1. Activate either „Kit“ or „Pattern“ mode.
2. Press the record button to activate the record mode.
3. If desired, set the metronome settings for the recording.
4. Press the record button again to start recording.
5. With the stop button you can pause the recording process and restart it with the record button. To ultimately stop the recording press the stop button twice. The display will read „Save the song to“.
6. Choose a place to save your recording with [-] / [+]. Existing data may be overwritten.
7. Press ENTER to confirm the save or cancel it by pressing EXIT.

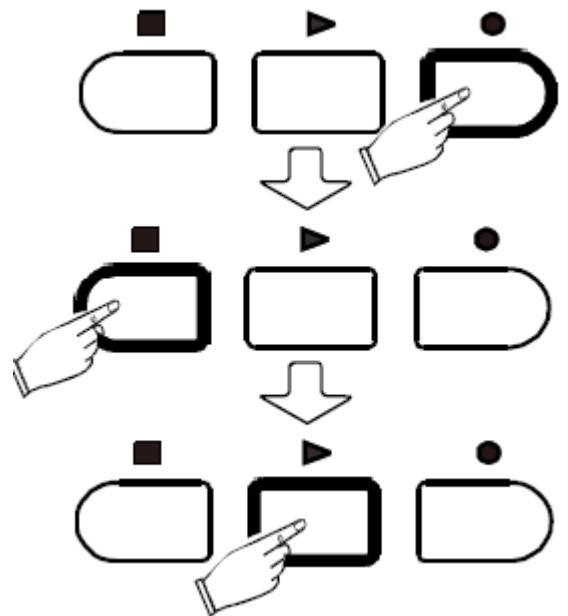

Restoring Factory Settings

1. Press SETUP and mark the menu „RESET“ by using either PAGE UP or PAGE DOWN.
2. Mark one of the following options with the scrolling wheel or the buttons:
 - „Kits“ (reset drum kits)
 - „Settings“ (reset system settings)
 - „Xtalk“ (reset cross talk)
 - „Songs“ (delete user created songs)
 - „All“ (reset all settings and delete all user created songs)
3. Confirm your choice with ENTER.
4. Restart the module.

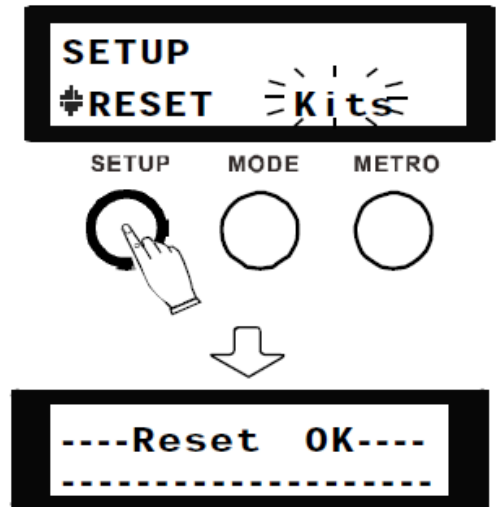

Setup

Press the SETUP button to advance to the system settings. Use PAGE DOWN/UP to select an option. If the option is shown with a blinking parameter, use the scrolling wheel to change it directly. If the item has an ENTER mark after it, press the ENTER button to enter the sub-menu for further options. After setting, press the EXIT button to exit and the display shows "Save Setup". Select "Yes" or "No", then press ENTER to save the setup or quit without saving.

Backvolume

Controls the volume of demo patterns and loops.

MIDI-Funktion

If the parameter for normal operation is switched „ON“, the module will use the programmed soundfiles. If the parameter for MIDI operation is switched „OFF“ (less latency), the module will send MIDI data.

Advanced Settings

Sensitivity

The higher this value is, the easier it will be to trigger a sound. If this value is too high it may cause cross talk problems.

Headroom

This sets the velocity dynamic range. This value is the velocity needed to get the max volume, so the lower the value is, the easier it is to create louder sounds.

Sense Time

Sets the interval between triggering. Increasing this value by a certain amount may avoid it being triggered multiple times by vibration in a very short time.

Trigger Curve

Sets the velocity curve for pads. The „Linear“ setting creates the most natural relation between a beat and the volume. A stronger strike with „Exp“ causes a stronger change in the volume (eg. dynamic). A stronger change with a softer strike is caused with „Log“. The setting „Spline“ changes the volume less when a different velocity is used. High volumes can be reached with a relatively soft strike intensity.

Cross Talk

This controls cross talk. Press ENTER to change the cross talk settings. Strike the pad with maximum force until the display shows OK. Change to the next pad and repeat this process. The velocity data of the other pads will be loaded automatically to avoid the cross talk effect.

Note Send

Default setting of MIDI note values, that are sent while in MIDI mode.

Rim Velocity

This controls the volume behavior of the rim trigger independent of the actual velocity. The higher this value is, the louder the rim trigger will be and vice versa.

Pedal Velocity

This controls the volume behavior of the HiHat pedal. The higher this value is, the louder the volume of the HiHat will be when the pedal is used and vice versa (pedal chick and pedal splash).

Calibration

This defines the HiHat pedal playing range. You can see the current playing range on the top right of the display. Choose the calibration option, press the pedal down fully and press ENTER to define the minimal playing range. Allow the pedal to bounce back and press ENTER to define the maximum playing range. You are advised not to set extreme values to allow fluid playing.

Split Point

This defines the velocity split point of the snare's rim trigger. If you hit the rim trigger of the snare softly, you will hear the cross-stick sound. Above the split point you will hear the rim-shot sound.

Chick Time

This defines the trigger disabling time after the pedal has been pressed down. It can be used to avoid unwanted triggering after physical contact with the pedal.

Splash Time

Defines the difficulty of triggering a pedal splash. (foot splash)

Peak Decay

Sets the signal decay of a selected part. The higher this value, the lesser the chance of skipping notes, but the easier it is to double-trigger them.

Rim Modifier

Rim judgement correction value. When a head sound is triggered while trying to play a rim sound turn up this value. When a rim sound is heard while trying to play a head sound lower this value.

Open Point

Defines at which point the HiHat is triggered with an open sound. The value displayed is the current position within the entire pedal range. The higher this value, the closer its position is to the pedal's release. This in turn means a smaller range to play an open HiHat.

Close Point

Defines at which point the HiHat is triggered with a closed sound. The value displayed is the current position within the entire pedal range. The lower this value, the closer its position is to the point where the pedal is fully pressed down. This in turn means a smaller range to play a closed HiHat. The range between open and closed position is for a half-open sound. If you want to increase the half-open range, you have to increase the values for OPEN POINT and decrease the values for CLOSE POINT.

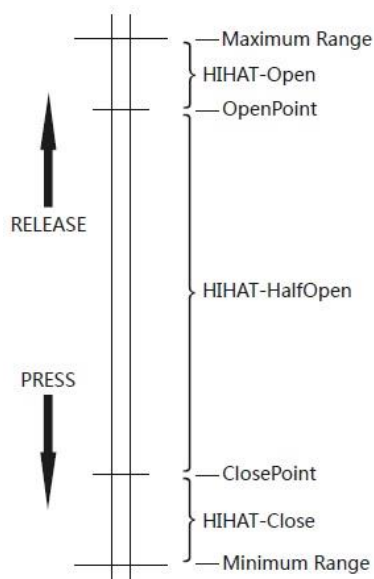

Appendix

List of Included Kits

1	Studio	8	Latin	15	DirtySouth
2	Standard	9	Brush	16	Nebula
3	Pop	10	Sunray	17	Drumstep
4	Jazz	11	Fiesta	18	Jungle
5	Metal	12	Mario	19	Utopia
6	Rock	13	Impulse	20	BlueBay
7	80s	14	Loop		

Pattern List

1	WalkWithTree	20	SoftAmour	39	Bartender
2	Soul	21	MelodicDeath	40	Celebration
3	Latin	22	SambaDance	41	Discover
4	Moskau	23	RockBlues	42	Shade
5	Heart	24	Fly	43	Echo
6	Fable	25	Bossa	44	LiteGroove
7	theStorm	26	Tango	45	River
8	Beowulf	27	Dancing	46	Jazz
9	Forever	28	CryintheRain	47	Love
10	Acid	29	NightTrain	48	Blues
11	Arcane	30	Arriba	49	Techno
12	toBeLoved	31	Batteries	50	OutofMyHeart
13	Rain	32	Revealite	51	MellowTone
14	PopAges	33	Breathe	52	theLight
15	ChaCha	34	BlueEyes	53	Take
16	Life	35	HeyMan	54	Angel
17	Home	36	Firerain	55	Bridge
18	Latina	37	NyanCats		
19	Reality	38	Supreme		

Voice List

KICK

Rock	Techno 03	Session	Kiss
Jazz	Techno 04	Vintage	DDDclean
Indie 01	Trance 01	Jungle 01	MorMOOG
Indie 02	Trance 02	Jungle 02	Morschlag2
Metal	Trance 03	Fiesta	Morschlag3
Funk 01	Trance 04	Birch 01	Morschlag1
Funk 02	Trance 05	YAM18	Morschlag5
8Bit 01	Trap 01	JAZZ V	Ballerfiako
8Bit 02	Trap 02	METAL V	Rave309
House 01	Trap 03	POP V	Y30
House 02	Trap 04	ROCK2V	SOLI606
House 03	Trap 05	ROCK V	SOLI808
RnB 01	Pop 01	ROCKBRIGHT	Y909
RnB 02	Pop 02	DGs8	Rosa
RnB 03	Pop 03	Pik	KissV
RnB 04	Pop 04	Sax	DG3
Techno 01	Jungle	Six	TR66RIM
Techno 02	Latin	Hot	Soli909RIM

SNARE

Rock	RnB 04	Latin Rimshot 02	POPV SS
Rock Rimshot	RnB R 01	Session	ROCKV2
Rock X	RnB R 02	Session Rimshot	ROCKV2 RS
Jazz 01	RnB X-Stick 01	Session X	ROCKV2 SS
Jazz 01 Rimshot	RnB X-Stick 02	Vintage	ROCKV3
Jazz X-Stick	Techno 01	Vintage Rimshot	ROCKV3 RS
Jazz 02	Techno 02	Vintage X-Stick	ROCKV3 SS
Jazz 02 Rimshot	TechnoC 01	Jungle	ROCKBRI
Indie 01	TechnoC 02	Jungle Rimshot	ROCKBRIRS
Indie Rimshot 01	Trance 01	Fiesta 01	ROCKBRISS
Indie X-Stick	Trance 02	Fiesta R 01	Soli8085
Indie 02	Trance 03	Fiesta X-Stick 01	FatschSd
Indie Rimshot 02	Trance 04	Fiesta 02	MBare
Metal	Trap 01	FiestaRimshot 02	OrgCP
Metal Rimshot	Trap 02	Fiesta Rimshot 03	SoliNoisy
Metal X-Stick	Trap 03	Jungle2	909
Funk 01	Trap 04	Jungle2 R	Abpunch
Funk Rimshot 01	Trap 05	BALLAD1	DD31
Funk X-Stick 01	Trap 06	RSBALLAD1	Dy2
Funk 02	Trap 07	SSBALLAD1	L9

Conga2	Pop3 Rimshot	16XNMas	80er2
Conga3	Pop4	Rim10XNMas	80er3
Conga4	Pop4 Rimshot	Rim12XNMas	80er4
Conga5	Brush1	Rim14XNMas	NOV_808TOM1
Conga6	Brush2	Rim16XNMas	NOV_808TOM2
Timbale1	Brush3	10BigReverb	NOV_808TOM3
Timbale2	Brush4	12BigReverb	NOV_808TOM4
8Bit1	Latin1	14BigReverb	SDS7_4TO1
8Bit2	Latin2	16BigReverb	SDS7_4TO2
8Bit3	Latin3	Rim10BigRev	SDS7_4TO3
8Bit4	Latin4	Rim12BigRev	SDS7_4TO4
House1 01	Session1	Rim14BigRev	909_TOM1
House2 01	Session2	Rim16BigRev	909_TOM2
House3 01	Session3	10MetaFilter	909_TOM3
House4 01	Session4	12MetaFilter	909_TOM4
House1 02	Vintage1	14MetaFilter	TED_TOM1
House2 02	Vintage1 Rimshot	16MetaFilter	TED_TOM2
House3 02	Vintage2	Rim12MetaFil	TED_TOM3
House4 02	Vintage2 Rimshot	Rim14MetaFil	TED_TOM4
House1 03	Vintage3	Rim16MetaFi	X1_ETOM1
House2 03	Vintage3 Rimshot	Rim10MetaFi	X1_ETOM2
House3 03	Vintage4	10SoliNathan	X1_ETOM3
House4 03	Vintage4 Rimshot	12SoliNathan	X1_ETOM4
RnB1	Jungle1	14SoliNathan	
RnB2	Jungle1 Rimshot	16SoliNathan	

RIDE

Rock	House 01	Jungle Bell	Pst21Ny1
Rock Bell	House 02	Fiesta	Pst21Ny2
Rock Edge	House 03	Fiesta Bell	Pst21 B1
Jazz	RnB	Fiesta Edge	Pst21 B2
Jazz Bell	Techno 01	Pst20Ny1	Pst21 E
Jazz Edge	Techno 02	Pst20Ny2	Pst21Br
Indie	Trance	Pst20Ny B	Pst21Br B
Indie Bell	Pop	Pst20Ny E1	Pst21Br E
Indie Edge	Pop Bell	Pst20Ny E2	Pst21EDGMe
Funk 02	Brush	Pst20Wd	Pst2TNy
Funk Bell 02	Brush Bell	Pst20Wd B	Pst2TNy B
Funk Edge 02	Brush Edge	Pst20Wd E	Pst2TNy E1
Funk 01	Session	Pst20Br	Pst2TNy E2
Funk Bell 01	Vintage	Pst20Br B	
Funk Edge 01	Vintage Bell	Pst20Br E	

CRASH

Rock1	8Bit2	SplashA12	Crash18
Rock1 Edge	House 01	SplashA12E	Crash18 E
Rock2	House 02	SplashB12	CrashB16 E
Rock2 Edge	House 03	SplashB12E	CrashB16 E
RockChina	House 04	Splash8	CrashB16
RockSplash	Trance1	Splash8E	Crash18
Jazz1	Trance2	China12Mal	Crash18 B
Jazz1 Edge 01	Trap1 01	China14Mal	Crash18Br
Jazz2	Trap2 01	China16Mal	Crash18 E1
Jazz2 Edge	Pop1	China20Sti	Crash18 E2
JazzSplash 01	Pop2	China30	Crash20
JazzSplash 02	Session1	Crash14 E	Crash20Beat
Indie1 01	Session2	Crash14	Crash20Br
Indie2 01	Vintage1	Crash16 E	Crash20EDGE
Indie1 02	Vintage2	Crash16	808_1CYM
Indie2 02	Jungle1	Crash17	NOV_CYMB
Funk1 02	Jungle2	Crash17br	Y808crash
Funk2 02	Fiesta1	Crash17 E	
8Bit1	Fiesta2	Crash17	

HI-HAT

Rock Open	House Open 03	Brush Pedal Splash	BalHHSp
Rock Closed	House Closed 03	Session Open	CDHH O
Rock Pedal Chick	RnB Open 01	Session Closed	CDHH C
Rock Half-Open	RnB Closed 01	Session Pedal Chick	CDHH P
Rock Pedal Splash	RnB Open 02	Session Pedal Splash	CDHH Half
Jazz Open 01	RnB Closed 02	Vintage Open	CDHH Sp
Jazz Closed 01	Techno Open 01	Vintage Closed	CCO O
Jazz Pedal Chick 01	Techno Closed 01	Vintage Pedal Chick	CCO C
Jazz Open 02	Techno Open 02	Vintage Half-Open	CCO P
Jazz Closed 02	Techno Closed 02	Vintage Pedal Splash	CCO Half
Jazz Pedal Chick 02	Trance Open 01	Jungle Open	CCO Sp
Indie Open 02	Trance Closed 01	Jungle Closed	808_2HH O
Indie Closed 02	Trance Open 02	Jungle Pedal Chick	808_3HH O
Indie Pedal Chick 02	Trance Closed 02	Jungle Half-Open	808_HH C1
Metal Open	Trap Open 01	Jungle Pedal Splash	808_HH C2
Metal Closed	Trap Closed 01	Fiesta Open	808HH P
Metal Pedal Chick	Trap Open 02	Fiesta Closed	909HHOP2
Funk Open 01	Trap Closed 02	Fiesta Pedal Chick	909_HHCL

Funk Closed 01	Trap Open 03	Fiesta Half-Open	909HHCL2
Funk Pedal Chick 01	Trap Closed 03	Fiesta Pedal Splash	CR78_HHO
Funk Open 02	Pop Open	CCMHH O	CR78_HHC
Funk Closed 02	Pop Closed	CCMHH C	NOV_HHOP
Funk Pedal Chick 02	Pop Pedal Chick	CCMHH P	NOV_1HHC
8Bit Open	Pop Half-Open	CCMHH Half	SakataHH O
8Bit Closed	Pop Pedal Splash	CCMHH Sp	SakataHH C
House Open 01	Brush Open	BalHH O	SakataHH P
House Closed 01	Brush Closed	BalHH C	Y808HH O
House Open 02	Brush Pedal Chick	BalHH P	Y808HH C
House Closed 02	Brush Half-Open	BalHH Half	

PERCUSSION

Cowbell	DubstepFX01	626_TAM	Tunggu5
FunkPercussion01	DubstepFX02	707_TAMB	Tunggu6
FunkPercussion02	DubstepFX03	ABcowbell	DavulGum1
8BitFX01	DubstepFX04	C78_Guiro	DavulGum2
8BitFX02	DubstepFX05	808congalo	DavulStik1
8BitFX03	Agogo01	808congame	DavulStik2
HouseFX01	Agogo02	Y30ZAP2	DavulFingr
HouseFX02	ShakerShort	X10_ZAP	BendirDum1
HouseFX03	ShakerLong	Bg	BendirDum2
HouseFX04	NoClp	Cai1	BendirTek1
HouseFX05	SDS7_CLP	Cai2	BendirTek2
HouseFX06	Soli909_CLAP	Cang	DarbukaGum
TranceFX01	909Clp	Gong1	DarbukaTek
TranceFX02	808clp	Gong2	DarbukaTak
TranceFX03	Abs	Gong3	DarbukaTok
TranceFX04	Abs5	Gong4	DarbukaTik
TranceFX05	808congahi	Guban	FingerCym1
TrapFX01	808 claves	Tunggu1	FingerCym2
TrapFX02	808 shaker	Tunggu2	
ElectricShaker	SakataAgogo	Tunggu3	
ElectricCowbell	Elec9Clap	Tunggu4	

Specifications

Configuration	3 X 10" Mesh Tom (with rim),14" Acoustic Mesh Snare (layered rims), 2 X 12" Crash Cymbal(with edge & choke), 14" Ride Cymbal(with edge, bell & choke), 13" Hi-Hat with Stand, 14" Acoustic Mesh Kick
Voice	720+ High Quality Sounds
Drum Kit	20 Preset Kits and 20 User Kits
Pattern	55 Songs,Drum On/Off,Accomp On/Off
Sound Effect	Reverb,Compressor,Equalizer with Professional DSP Processor
Equalizer	4-Band Equalizer,Real-time Control
Metronome	On/Off,Tempo,Voice,Time Signature,TapTempo
SetupMenu	Back Volume,MasterTune,Local,Fader FX Setup, FaderMIDISetup,Advanced(Sensitivity,Headroom,Trigger Curve,AutoCrosstalk,MIDI Note Send,RimVelocity,Pedal,SnareRimSplitPoint),Reset
PadEdit	Voice,Volume,Pan,Pitch,Reverb
Record	15 Songs
Display	Back-light LCD, 2 Row X16 Characters
Power	12V DC
Aux. Socket	Headphone,Line In, Line Out(L/R),USB, Power, External TriggerX2
New Feature	New acoustic wooden snare and kick.6 faders in three modes: Real-time pad volume control,FXcontrol(Reverb, compressor and 4 -band equalizer),MIDIcontrol. Kit with loop function. 5 step Hihat Pedal with stand.

WEEE-Declaration / Disposal

Your product is designed and manufactured with materials and components of high quality, which are recyclable and can be reused. The symbol means that your product should be disposed of separately from household waste when it reaches its end of life. Please dispose of this equipment at your local collection point or recycling center. Please help to protect the environment in which we all live.

All specifications and appearances are subject to change without notice. All information was correct at time of printing. Musikhaus Kirstein GmbH does not guarantee for the accuracy or completeness of any description, photograph or statement contained in this manual. Printed colors and specifications may vary slightly from product. Products from Musikhaus Kirstein GmbH are only sold through authorized dealer. Distributors and dealers are not agents of Musikhaus Kirstein GmbH and have no authority to bind Musikhaus Kirstein GmbH legally in any way. This manual is protected by copyright. Any copying or reprint, even in excerpts, is only allowed with written consent of Musikhaus Kirstein GmbH. The same applies to reproduction or copying of images, even in altered form.

 **KIRSTEIN.de**

Musikhaus Kirstein GmbH
Bernbeurener Str. 11
86956 Schongau – Germany
Telefon/Phone: 0049-8861-909494-0
Telefax/Fax: 0049-8861-909494-19

