

Classic Cantabile KH-238 Kopfhörer HiFi dynamisch

ArtNr.: 00016331



Bedienungsanleitung

Version: 10.2024

Vielen Dank, dass Sie sich für dieses Produkt entschieden haben. Um sicherzustellen, dass Sie mit dem Classic Cantabile Kopfhörer voll und ganz zufrieden sind, lesen Sie sorgfältig und verstehen Sie diese Bedienungsanleitung, bevor Sie unser Produkt verwenden. Bewahren Sie diese Bedienungsanleitung an einem sicheren Ort auf. Die Bedienungsanleitung muss an alle nachfolgenden Anwender weitergegeben werden.



Bedienungsanleitung beachten!



WARNUNG

Mit dem Signalwort **WARNUNG** sind die Gefahren gekennzeichnet, die ohne Vorsichtsmaßnahmen zu schweren Verletzungen führen können.



HINWEIS

Mit dem Signalwort **HINWEIS** sind allgemeine Vorsichtsmaßnahmen gekennzeichnet, die im Umgang mit dem Produkt beachtet werden sollen.



HINWEIS

Bilder und Bildschirmdarstellungen in dieser Bedienungsanleitung können vom Erscheinungsbild des tatsächlichen Produkts geringfügig abweichen, solange dies keine negativen Auswirkungen auf die technischen Eigenschaften und Sicherheit des Produkts hat.



HINWEIS

Alle personenbezogenen Formulierungen in dieser Bedienungsanleitung sind geschlechtsneutral zu betrachten.

Diese Bedienungsanleitung gilt für Personen, die von einer für ihre Sicherheit verantwortlichen Person beaufsichtigt oder in die Bedienung des Gerätes eingewiesen wurden und nachgewiesen haben mit dem Gerät umgehen zu können.



WARNUNG

**Kinder sollten beaufsichtigt werden, um sicherzustellen, dass sie nicht mit dem Kopfhörer spielen.
Der Kopfhörer ist kein Spielzeug**

Alle Informationen in dieser Bedienungsanleitung wurden nach bestem Wissen und Gewissen kontrolliert. Weder Autor noch Herausgeber können jedoch für Schäden haftbar gemacht werden, die in Zusammenhang mit der Verwendung dieser Bedienungsanleitung stehen.

Sonstige, in diesem Dokument aufgeführte Produkt-, Marken- und Unternehmensbezeichnungen können die Warenzeichen ihrer jeweiligen Eigentümer sein. Die Einhaltung sämtlicher anwendbarer Urheberrechtsgesetze liegt in der Verantwortung des Anwenders dieses Dokuments.

Detaillierte Sicherheitshinweise:**⚠ HINWEIS**

- Lesen Sie diese Anweisungen und bewahren Sie diese Anleitung auf.
- Beachten Sie alle Warnungen. Befolgen Sie alle Anweisungen.
- Verwenden Sie dieses Gerät nicht im Wasser.
- Reinigen Sie das Gerät nur mit einem trockenen Tuch.
- Legen Sie das Gerät nicht in auf Wärmequellen wie Heizkörpern, Öfen oder andere Geräte, die Wärme erzeugen.
- Achten Sie auf die Lautstärke! Hören mit zu hohem Lautstärkepegel kann Ihr Gehör dauerhaft schädigen.
- Wenden Sie sich bezüglich aller Reparatur- /Wartungsarbeiten an qualifiziertes Servicepersonal. Öffnen Sie das Gerät bzw. das Gehäuse nicht eigenmächtig. Eine Wartung ist erforderlich, wenn das Gerät auf irgendeine Weise beschädigt wurde, z. B. wenn das Kabel beschädigt ist, Flüssigkeit verschüttet wurde oder das Gerät Regen oder Feuchtigkeit ausgesetzt war, nicht ordnungsgemäß funktioniert.

**Beschreibung:****Funktion:**

Der Kopfhörer kann mit jedem Abspielgerät (z.B. CD-Player) als auch Instrument (z.B. E-Drumset, Keyboard oder Piano) verbunden werden. Hierbei ist je nach Buchse lediglich auf den Einsatz der korrekten 3,5 mm Klinke oder der 6,3 mm Klinke des Adapters zu achten.(Adapter liegt bei)

⚠ WARNUNG

Achten Sie auf die Lautstärke! Hören mit zu hohem Lautstärkepegel kann Ihr Gehör dauerhaft schädigen.

Wartung

Ihr Gerät erfordert keine besondere Wartung. Wenden Sie sich jedoch im Falle einer Fehlfunktion an ein zugelassenes Servicecenter oder den Hersteller

Reinigung

Verwenden Sie zur Reinigung ein fusselfreies und nur leicht feuchtes Tuch.

Technische Spezifikationen:

System: dynamische Kopfhörer

Nennimpedanz: 32 Ohm

Lautsprecher: Stereo

Frequenzbereich: 20-20000 Hz

Empfindlichkeit: 110dB SPL

WEEE-Erklärung

(Waste of Electrical and Electronic Equipment)

Ihr Produkt wurde unter Verwendung hochwertiger Materialien und Komponenten entwickelt und hergestellt, die recycelbar und wiederverwendbar sind. Das Symbol bedeutet, dass Ihr Produkt am Ende seiner Lebensdauer vom Hausmüll getrennt entsorgt werden muss.

Entsorgen Sie dieses Gerät bei Ihrer örtlichen Sammelstelle oder Recyclingstelle. Bitte helfen Sie mit, die Umwelt zu schützen, in der wir alle leben.

Alle technischen Daten und Erscheinungsbilder können ohne vorherige Ankündigung geändert werden. Alle Angaben waren zum Zeitpunkt der Drucklegung korrekt. Die Musikhaus Kirstein GmbH übernimmt keine Gewähr für die Richtigkeit oder Vollständigkeit der in diesem Handbuch enthaltenen Beschreibungen, Fotos oder Aussagen. Gedruckte Farben und Spezifikationen können geringfügig vom Produkt abweichen. Produkte der Musikhaus Kirstein GmbH werden nur über autorisierte Händler vertrieben. Distributoren und Händler sind keine Vertreter der Musikhaus Kirstein GmbH und nicht befugt, die Musikhaus Kirstein GmbH in irgendeiner Weise rechtlich zu binden.

Diese Bedienungsanleitung ist urheberrechtlich geschützt. Die Vervielfältigung dieser Bedienungsanleitung, auch auszugsweise, ist nur mit Genehmigung der Musikhaus Kirstein GmbH gestattet. Gleiches gilt für die Vervielfältigung oder das Kopieren von Bildern, auch in geänderter Form.

© 2024

 **KIRSTEIN.de**

Musikhaus Kirstein GmbH

Bernbeurener Str. 11

D-86956 Schongau

info@kirstein.de

www.kirstein.de

Telefon/Phone: +49(0)8861 / 90 94 94 -0



Classic Cantabile KH-238 Headphones HiFi dynamic

Item number: 00016331



User Manual

Version: 10.2024

Thank you for choosing this product.

To ensure that you are fully satisfied with the Classic Cantabile headphones, read this manual carefully and understand these instructions before using our product. Keep these operating instructions in a safe place. The operating instructions must be passed on to all subsequent users.



Please carefully follow the instructions!



The signal word **WARNING** indicates the dangers that can lead to serious injuries without precautionary measures.



The signal word **NOTE** indicates general precautionary measures that should be observed when handling the product.

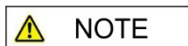

Images and screen shots in this manual may differ slightly from the appearance of the actual product as long as this has no negative effects on the technical properties and safety of the product.

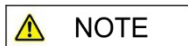

All personal formulations in these operating instructions are to be considered gender-neutral.

These operating instructions apply to persons who have been supervised by a person responsible for their safety or who have been instructed in the operation of the device and have demonstrated that they can handle the device.



Children should be supervised to ensure that they do not play with the device.

Do not leave children unattended. The product is not a toy!

All information in this operating manual has been checked to the best of our knowledge and belief. However, neither the author nor the publisher can be held liable for any damage associated with the use of this manual.

Other product, brand and company names mentioned in this document may be the trademarks of their respective owners. Compliance with all applicable copyright laws is the responsibility of the user of this document.

Detailed safety information:**⚠ NOTE**

- Read these instructions. Keep these instructions.
- Heed all warnings. Follow all instructions.
- Do not use this device near water.
- Only clean the device with a dry cloth.
- Do not block any ventilation openings.
- Do not place the device near heat sources such as radiators, stoves or other devices that generate heat.
- Pay attention to the volume! Hearing at a high-volume level can permanently damage your hearing.
- Contact qualified service personnel for all repair / maintenance work. Do not open the device or the housing yourself. Maintenance is required if the device has been damaged in any way, e.g., if the power cord or plug is damaged, liquid has been spilled or objects have fallen into the device, the device has been exposed to rain or moisture, is not working properly or has been dropped.

**Function:**

The headphones can be connected to every playing device (e.g., CD-players) as well as instrument (e.g., E-drumset, keyboard or piano). It is only important to note which jack plug is required for the used device: the 3.5 mm jack or the 6.3 mm jack of the adapter. (Adapter is included in delivery)

⚠ WARNING Pay attention to the volume! Hearing at a high-volume level can permanently damage your hearing.

Maintenance

Your device does not require any special maintenance. However, in the event of a malfunction, contact an approved service center or the manufacturer

Cleaning

Use a lint-free and only slightly damp cloth for cleaning.

Technical specifications:

System: dynamic headphones

Impedance: 32 Ohm

Speakers: Stereo

Frequency range: 20-20000 Hz

Sensitivity: 110dB SPL

WEEE declaration (Waste of Electrical and Electronic Equipment)

Your product has been developed and manufactured using high quality materials and components that are recyclable and reusable. The symbol means that your product must be disposed of separately from household waste at the end of its service life.

Dispose of this device at your local collection or recycling centre, please help protect the environment we all live in.

All technical data and appearances are subject to change without notice. All information was correct at the time of printing. Musikhaus Kirstein GmbH assumes no liability for the correctness or completeness of the descriptions, photos or statements contained in this manual. Printed colours and specifications may differ slightly from the product. Musikhaus Kirstein GmbH products are only sold through authorized dealers. Distributors and dealers are not representatives of Musikhaus Kirstein GmbH and are not authorized to bind Musikhaus Kirstein GmbH legally in any way.

This manual is protected by copyright. Reproduction of these operating instructions, in whole or in part, is only permitted with the approval of Musikhaus Kirstein GmbH. The same applies to the duplication or copying of images, even in modified form.

© 2024

 **KIRSTEIN.de**

Musikhaus Kirstein GmbH

Bernbeurener Str. 11

D-86956 Schongau

info@kirstein.de

www.kirstein.de

Phone: +49(0)8861 / 90 94 94 -0



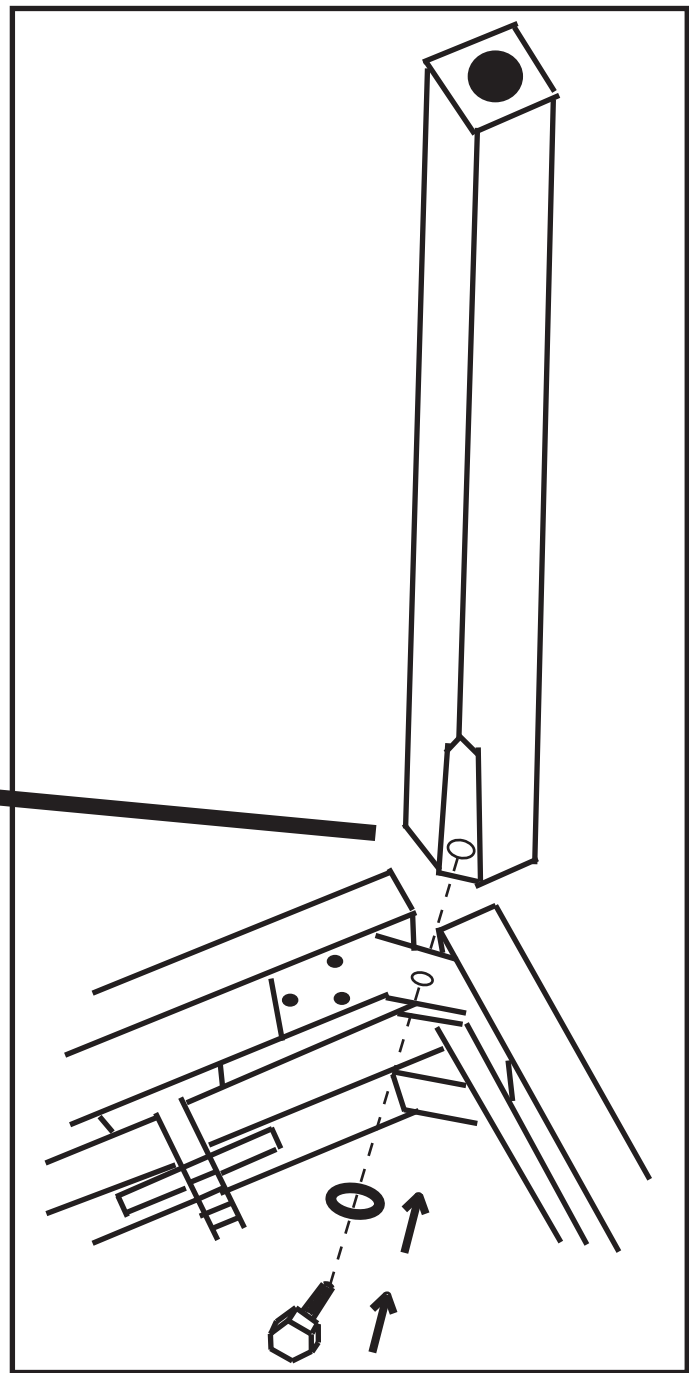

VORSICHTSMASSNAHMEN (BITTE SORGFÄLTIG DURCHLESEN) Kinder sollten beaufsichtigt werden, um sicherzustellen, dass sie dieses Produkt nicht als Spielzeug verwenden. Lassen Sie Kinder niemals unbeaufsichtigt mit dem Verpackungsmaterial spielen. **Warnhinweise:** Stellen Sie das Produkt stets auf eine geeignete Oberfläche ab, um ein Wackeln oder Umfallen zu verhindern. **Vorsichtsmaßnahmen:** Um Schäden am Produkt zu vermeiden, stellen Sie es nicht an Plätze mit hohen Temperaturen oder viel Staub, stellen Sie es nicht direkt neben eine Klimaanlage und vermeiden Sie direkte Sonneneinstrahlung. Wenden Sie im Umgang mit dem Produkt keinerlei Gewalt an und stellen Sie keine zu schweren Gegenstände darauf. **Ort:** Setzen Sie das Produkt nicht den folgenden Bedingungen aus, um Verformungen, Verfärbungen oder größere Schäden zu vermeiden: Direktes Sonnenlicht, extreme Temperatur oder Luftfeuchtigkeit, übermäßig staubiger oder schmutziger Ort, starke Vibrationen oder Stöße. **Reinigung:** Reinigen Sie das Produkt nur mit einem weichen, trockenen Tuch. Verwenden Sie keine Farbverdünner, Lösungsmittel, Reinigungsflüssigkeiten oder chemisch imprägnierte Wischtücher. **Handhabung:** Üben Sie keine übermäßige Kraft auf Bedienelemente wie z.B. Schalter, Knöpfe aus. Technische Änderungen und Änderungen im Erscheinungsbild sind vorbehalten. Alle Angaben entsprechen dem Stand bei Drucklegung. Für die Richtigkeit und Vollständigkeit der enthaltenen Beschreibungen, Abbildungen und Angaben übernimmt Musikhaus Kirstein GmbH keinerlei Gewähr. Abgebildete Farben und Spezifikationen können geringfügig vom Produkt abweichen. Musikhaus Kirstein GmbH - Produkte sind nur über autorisierte Händler erhältlich. Distributoren und Händler sind keine Handlungsbevollmächtigten von Musikhaus Kirstein GmbH und haben keinerlei Befugnis, die Musikhaus Kirstein GmbH in irgendeiner Weise, sei es ausdrücklich oder durch schlüssiges Handeln, rechtlich zu binden. Diese Bedienungsanleitung ist urheberrechtlich geschützt. Jede Vervielfältigung, bzw. jeder Nachdruck, auch auszugsweise, und jede Wiedergabe der Abbildungen, auch in verändertem Zustand, ist nur mit schriftlicher Zustimmung der Firma Musikhaus Kirstein GmbH gestattet.

PRECAUTIONS (PLEASE READ CAREFULLY) Children should be supervised to ensure that they do not use this product as a toy. Never let children play with the packaging material unsupervised. **Warning:** Always place the product on a suitable surface to prevent it from wobbling or falling over. **Precautions:** To avoid damage to the product, do not place it in places with high temperatures or a lot of dust, do not place it directly next to an air conditioner and avoid direct sunlight. Do not use force when handling the product and do not place objects that are too heavy on it. **Location:** Do not expose the product to the following conditions to avoid warping, discoloration, or major damage: direct sunlight, extreme temperature or humidity, excessively dusty or dirty location, strong vibration or shock. **Cleaning:** Only clean the product with a soft, dry cloth. Do not use paint thinners, solvents, cleaning fluids, or chemically impregnated wipes. **Handling:** Do not exert excessive force on controls such as switches, buttons. Technical changes and changes in appearance are reserved. All information corresponds to the status at the time of printing. Musikhaus Kirstein GmbH assumes no liability for the correctness and completeness of the descriptions, illustrations and information contained. Shown colors and specifications may differ slightly from the product. Musikhaus Kirstein GmbH - Products are only available through authorized dealers. Distributors and dealers are not authorized representatives of Musikhaus Kirstein GmbH and have no authority to bind Musikhaus Kirstein GmbH legally in any way, be it expressly or through coherent action. This manual is protected by copyright. Any duplication or reprint, even in part, and any reproduction of the images, even in a modified state, is only permitted with the written consent of Musikhaus Kirstein GmbH.

STEINMAYER

DP 361

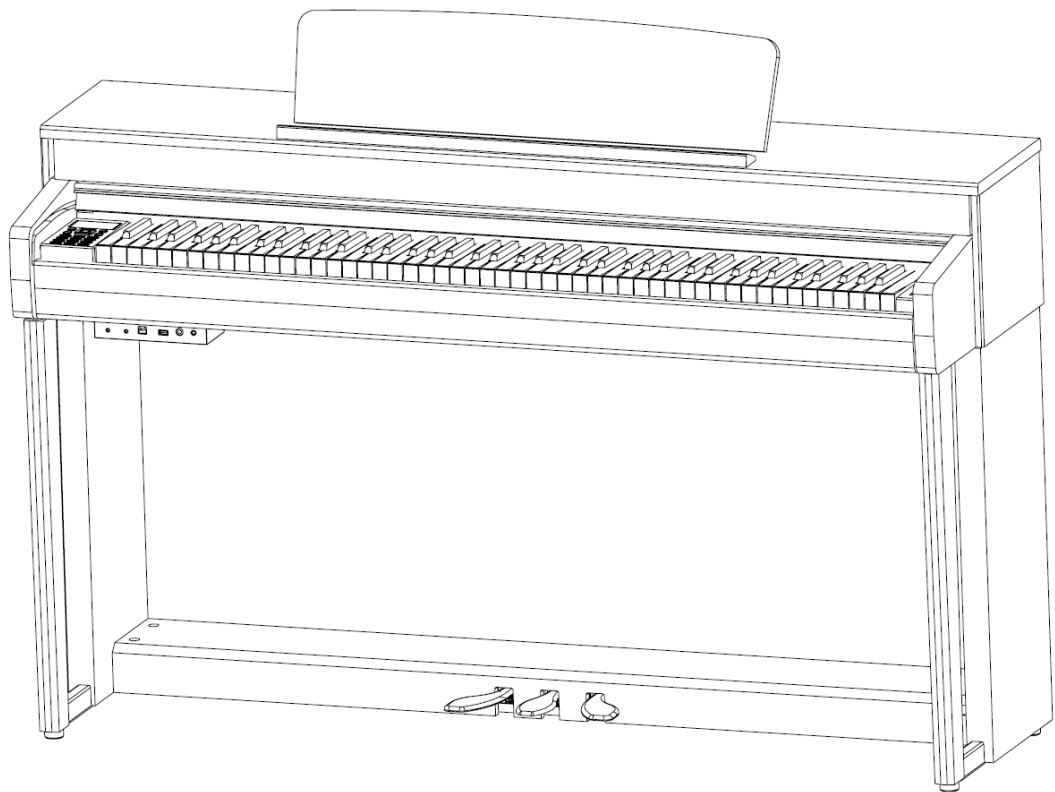

Owner's Manual

Version: 11/2019

© 2019

This manual is protected by copyright. Any copying or reprint, even in excerpts, is only allowed with consent of Musikhaus Kirstein GmbH. The same applies to reproduction or copying of images, even in altered form.

Contents

Assembly	1
Assembly of the pedal bar and side panels	2
Attach the Back.....	2
Fitting the piano console	3
Connect the pedal cable and power cord	3
Basic operation	4
Power switch.....	4
Auto Power Off (APO)	4
Headphone jacks	4
Connections	5
Pedals	6
Connecting the pedal cable	6
How to operate the pedals	6
Operating unit	7
Using the MOVE/ENTER keys	8
Using the BACK (↶) and HOME (▲) buttons	8
Operation	8
Adjusting the volume	8
Choosing a Tone (Voice).....	8
Voice-Liste	9
Dual	10
Layer.....	10
Split.....	11

STEINMAYER

Layer+Split	11
Move the split point	11
Twin Piano	12
Metronome	13
Start / Stop	13
Metronome Settings	13
TEMPO	13
“Piano Assist” Function.....	14
To start Piano Assist	14
Drum Player	14
Piano Player.....	15
Chord specification for the piano player	16
Select the Method	17
Further settings	18
“Record” Function.....	18
Recording and playback.....	18
Recording with Piano Assist.....	19
Music Databank	20
USB-Player	21
Registration Memory	21
Saving a Registration	21
Calling up a Registration	22
Changing the Registration Memory Bank	22
BrainCare	22
BrainCare List	23
Function menu	24
System.....	25
Controller	27
Voice.....	28

STEINMAYER

Balance	30
MIDI	31
Bluetooth.....	31
Bluetooth.....	31
Bluetooth Audio.....	31
Bluetooth-MIDI	32
MIDI Chart.....	33
GM-Voice.....	34
Percussion	35
Trouble Shooting.....	36
Product Specifications	37
WEEE Declaration.....	38

Thank you for choosing this product.

To ensure that you are fully satisfied with this product, carefully read and understand this manual before using this instrument. Keep this manual in a safe place. The operating instructions must be passed on to all subsequent users.



Observe operating instructions!



The WARNING signal word identifies hazards that, without precautions, could result in serious injury.



The signal word NOTE indicates general precautions that should be observed when handling the product.



Images and screen images in this manual may differ slightly from the actual product's appearance, as long as it does not adversely affect the technical characteristics and safety of the product.



All personal phrasing in this manual should be considered gender neutral.

These operating instructions apply to responsible persons and users who have been supervised by a person responsible for their safety or instructed in the operation of the device and who have proven to be able to handle the device.



**Children should be supervised to ensure that they do not use this device as a toy.
Never allow children to play unattended with the packaging material.**



Danger of property damage! We are not liable for accidents that occur as a result of non-observance of the safety instructions or due to incorrect handling.

All information in this manual has been checked to the best of our knowledge and belief. However, neither author nor publisher can be held liable for any damage related to the use of this manual.

Other product, brand and company names mentioned herein may be the trademarks of their respective owners. Compliance with all applicable copyright laws is the responsibility of the user of this document.

 **WARNING**

Caution

Please observe the following basic information in order not to endanger yourself or others and to avoid damage to external devices.

 **NOTE**

Warning

Do not disassemble the instrument and do not modify it. This could result in electric shock. Entrust a specialist workshop with any necessary service and maintenance or contact your dealer.

If you notice that the power cord is showing signs of wear, the unit shows malfunctions, burns, smells or smokes, unplug the power cord immediately and have a technician repair it.

Before you clean the instrument, you should disconnect it from the mains power.

Always place the instrument on a level, stable surface to ensure a secure footing.

Do not use the instrument in a damp or wet environment.

Do not place vessels that are filled with liquids on the instrument, such as vases, glasses or bottles.

Do not place small objects on it that could slip in, such as Hairpins, sewing needles or coins.

Do not place burning candles on the instrument.

 **NOTE**

Precautions

To avoid damage to the instrument, do not place it in places with high temperatures or dust, do not place it next to an air conditioner and avoid direct sunlight.

Do not place the instrument near other electrical equipment to avoid interference.

Do not use force when handling the instrument or place heavy objects on it.

Disconnect the instrument from the power if you are not going to use it for a long time. To disconnect the device from the mains, pull the plug, not the cable. Please handle the power cable with care. It should not be near radiators, you should not place heavy objects on it and move it so that people can not step on it or fall over it.

Please note that continuous high volume can permanently damage your hearing.

Adjust the volume carefully.

 **WARNING**

Power adapter

Please connect the supplied power adapter to a power outlet with the correct voltage. Do not connect it to mains voltages other than those for which the instrument is intended. Unplug the power cord if you are not going to use the product for a long time or if there is upcoming a thunderstorm.

Assembly

Please unpack the instrument carefully and make sure all components listed below are in perfect condition.

If any items are missing or damaged, please contact the manufacturer.

Piano console

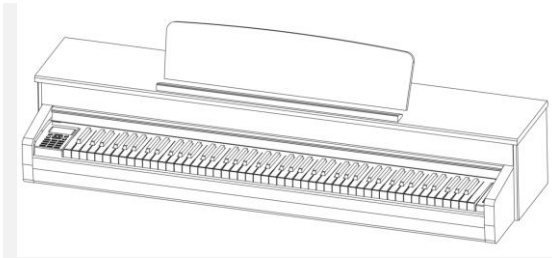

Operating manual (possibly as download)

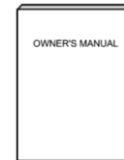

Left / Right foot (a, b)

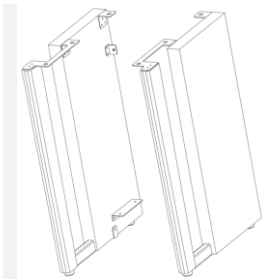

Pedal unit (c)

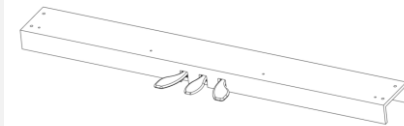

Back (d)

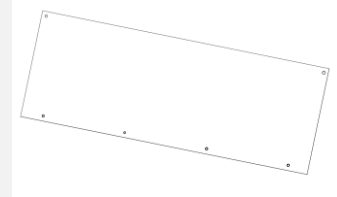

Screws pedal box

(e) 4 pieces M6 x 16

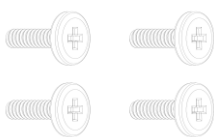

Screws for the Back

(f) 4 pieces M3,5 x 25
(g) 2 pieces M4 x 13

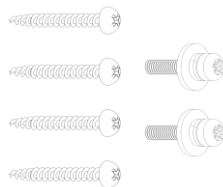

Screws for the console

(h) 6 pieces M6 x 16

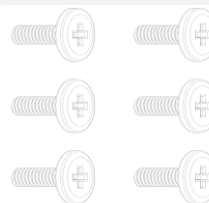

Power adapter

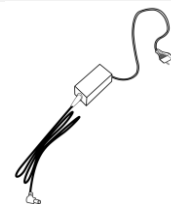

► It may be useful to keep the packaging materials in case the instrument needs to be transported to a faraway place.

Assembly of the pedal bar and side panels

Attach the pedal bar (c) between the two side panels (a, b) using the screws (e)

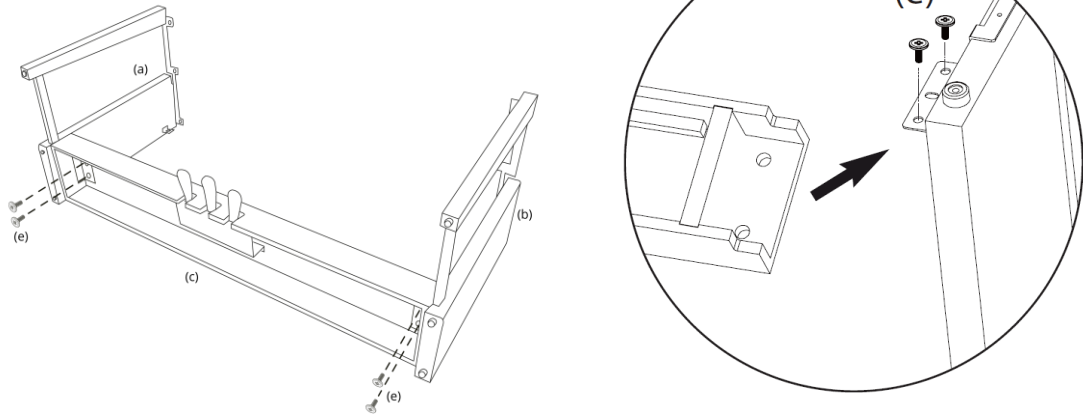

Unscrew the spacer screw under the pedal unit until it makes contact with the ground and the pedal unit can be supported against the pedal pressure towards the ground.

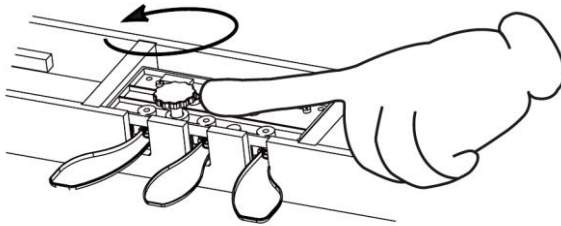

Attach the Back

Attach the Back to the base from the rear and attach it to the side panels using the screws (g).

Make sure the base is properly aligned and secure the Back to the pedal bar using the screws (f).

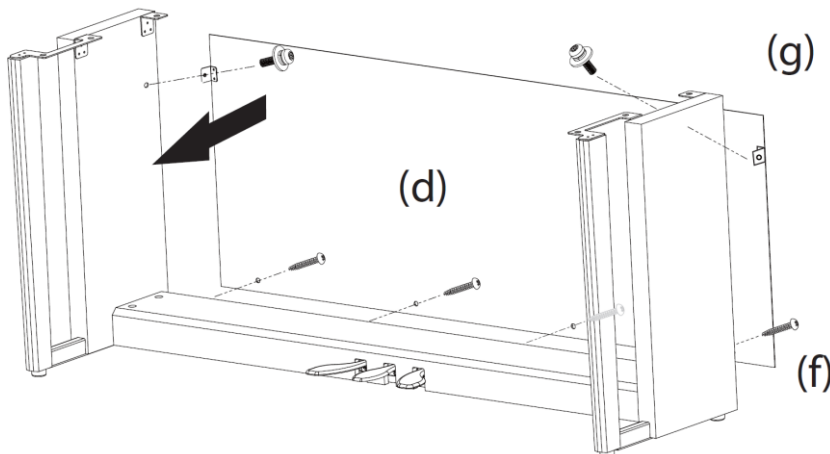

Fitting the piano console

Carefully place the piano console on the base. Pay attention to your fingers. Connect the two components using the screws (h)

Set up the music stand and hold it at the desired angle with the metal base

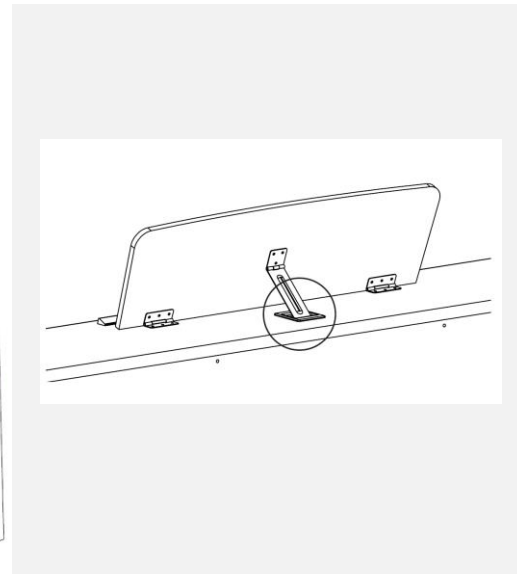
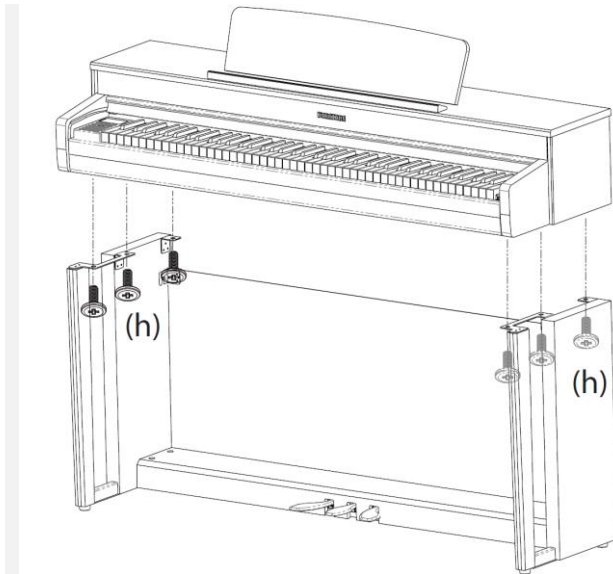

Connect the pedal cable and power cord

Connect the pedal cable (this is already placed on the underside of the pedal bar) with the matching connection on the underside of the piano console

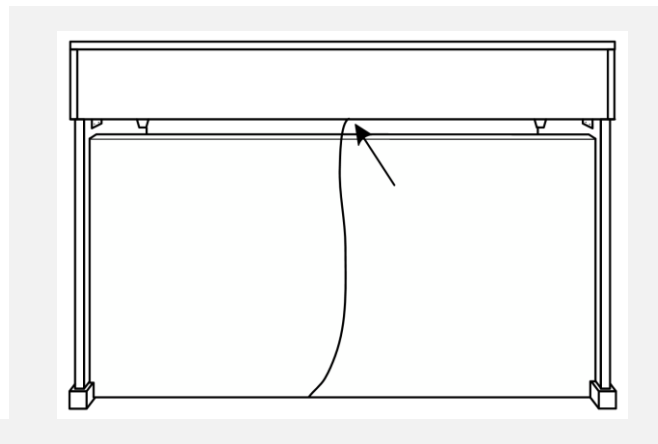
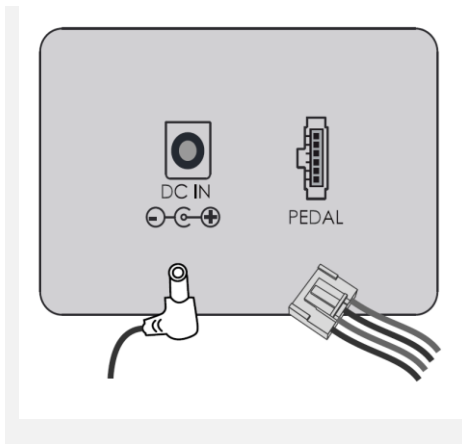

Basic operation

Power switch

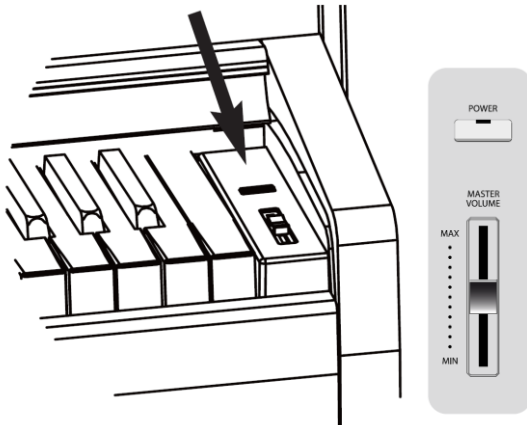

Insert the jack plug of the power supply unit into the socket at the bottom of the console and then plug the power plug into the socket.

Now press the power button to turn on the instrument.

► When switching on for the first time, "German G.Piano" is selected as "Voice".

► Adjust the desired volume with the MASTER VOLUME control.

To turn off the instrument, press and hold the power button. All settings made will be reset to the default value when restarting. Recordings are saved in the memory.

Auto Power Off (APO)

This instrument automatically shuts off, if it is not used for 30 minutes. This setting can be changed via function-menu.

Headphone jacks

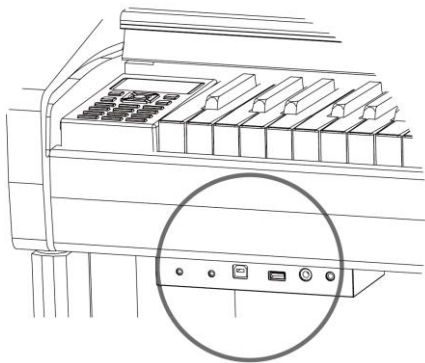

There are two headphone jacks in the connection panel at the bottom left of the piano console

► The loudspeakers of the instrument are automatically deactivated when a headphone is connected

► To allow the connection of both commercially available headphone plug, the instrument has a 6.35 mm and a 3.5 mm headphone jack.

► Both headset connections can be used simultaneously. Thus, two players can practice together through headphones.

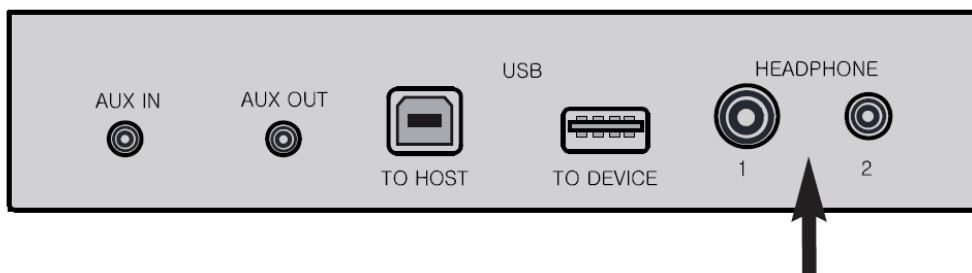

Connections

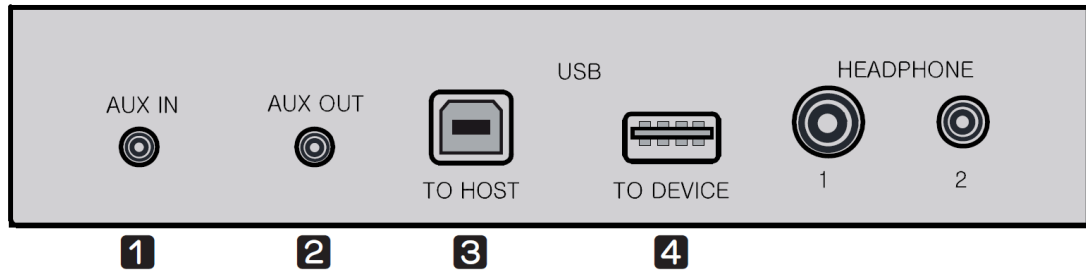

Connection panel at the bottom left of the piano console

1 Aux In – Stereo 3.5mm

The Aux-In jack can be used to connect external audio devices such as Mp3 players. The incoming music signals through this jack are played through the loudspeakers of the piano. It is recommended to turn off both devices before making a cable connection. Initially, to avoid damage, set the volume of both devices to a low level.

2 Aux Out – Stereo 3.5mm

The Aux-Out jack can be used to connect external amplifiers or recorders. The music signals sent out via this jack can be played back via an external amplifier or recorded by a recording device. It is recommended to turn off both devices before making a cable connection. Initially, to avoid damage, set the volume / sensitivity of both devices to a low level.

3 USB to HOST - (USB – B)

The USB-to-HOST jack connects to the computer to transmit MIDI or audio data. The connection is made via a USB A to B cable (not included).

To use the piano as a MIDI input device, start MIDI-capable software (not included) on your computer and select the piano as a MIDI device within the application.

To use the piano as an audio source, select the instrument in the audio settings of the computer as the audio device.

⚠ NOTE: The instrument uses USB 2.0. It is recommended not to exceed a cable length of 1.2m. The instrument supports Windows XP or higher, Mac OS X and iOS 4.0 and higher. Compatibility with Android Devices may be limited depending on the manufacturer and version. No further drivers are needed. After connecting, to avoid malfunction, wait a few seconds before using the instrument.

4 USB to DEVICE – (USB – A)

An external storage medium in the form of a USB stick can be attached to the USB-to-device socket. The MP3 and SMF files from the USB stick can be played via the piano.

⚠ NOTE The instrument supports USB sticks with FAT32 formatting. Do not remove the stick during data transfer. After attaching the stick, to avoid malfunctions, wait a few seconds before using the piano.

Pedals

The instrument has three pedals. These simulate the pedals of a real concert piano.

Connecting the pedal cable

Disconnect the pedal cable which is fixed under the pedal box and connect it to the corresponding socket on the underside of the piano console.

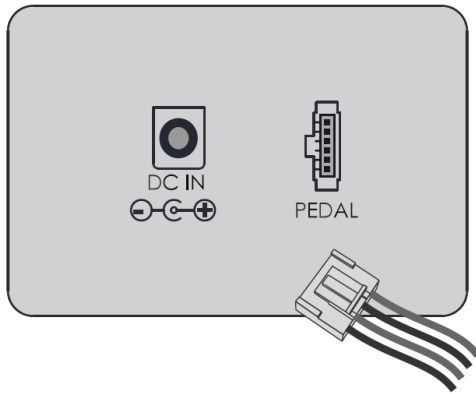

How to operate the pedals

1 Sustain Pedal (right pedal)

This pedal has the same function as the sustain pedal of an acoustic piano. Notes played while the pedal is pressed continue to sound when the key on the keyboard is released. This Instrument also features a half-pedal-function. This function simulates the sound of a piano string slightly touched by the damper with the pedal pressed lightly.

2 Sostenuto Pedal (middle pedal)

This pedal has the same function as the Sostenuto-Pedal of a concert piano. It behaves similar to the sustain pedal, but only the sounds are retained which are triggered simultaneously with the pedal.

3 Soft Pedal (left pedal)

This pedal has the same function as the Soft Pedal of an acoustic piano. Pressing this pedal softens and thins the sound a bit.

Rotary-Effect-Pedal (left and middle pedal)

If a Rotary-Effect is selected in the effect section, the left pedal can be used to switch to a faster speed. With the middle pedal you can stop abruptly the Rotary-Effect.

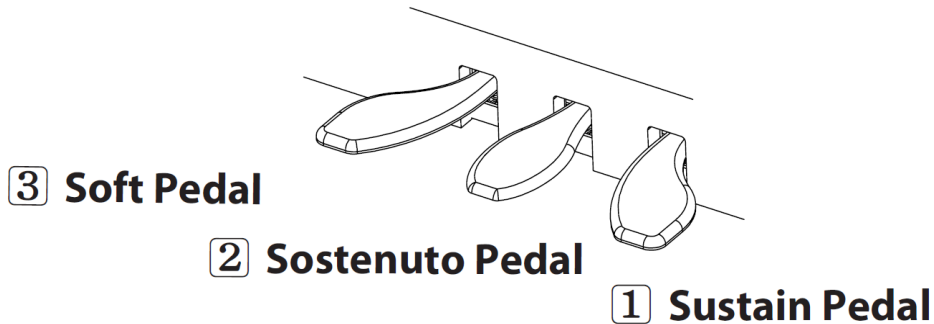

Operating unit

<p>The diagram shows the control panel of the Steinmayer operating unit. At the top is the 'BrainCare' logo. Below it is a large LCD screen (a). Under the screen are three buttons: 'Reg. SAVE' (c), a central 'MOVE/ENTER' button (b) with four directional arrows, and 'Reg. LOAD' (d). Below these are 'TEMPO' (e) and 'FUNCTION' (f) buttons. The panel features six registration buttons: R1 G.PIANO, R2 E.PIANO, R3 ORGAN, R4 STRINGS, R5 (g), and R6 OTHERS. Below the registrations are three buttons: 'METRONOME' (h), 'DUAL' (i), and 'MUSIC' (j). At the bottom are three buttons: 'RECORD' (k), 'PLAY/STOP' (l), and 'PIANO ASSIST' (m).</p>	<p>a LCD screen</p> <p>b MOVE/ENTER</p> <p>c BACK (↶) / Reg. SAVE</p> <p>d HOME (⬆) /Reg. LOAD</p> <p>e TEMPO</p> <p>f FUNCTION</p> <p>g Voice / Registration</p> <p>h METRONOME</p> <p>i DUAL</p> <p>j MUSIC</p> <p>k RECORD</p> <p>l PLAY / STOP</p> <p>m PIANO / ASSIST</p>	<p>page 8</p> <p>page 8,21</p> <p>page 8,22</p> <p>page 13</p> <p>page 24</p> <p>page 8,21</p> <p>page 13</p> <p>page 10</p> <p>page 20</p> <p>page 18</p> <p>page 15,18,21</p> <p>page 14</p>
---	--	--

Using the MOVE/ENTER keys

Bring the cursor on the screen with the arrow keys to the desired position. Press the Enter key in the middle of the arrow keys to confirm your selection and open menus.

Using the BACK (↶) and HOME (▲) buttons

The back button takes you back one step.

The Home button returns you to the main screen. In recording, music or piano assist mode, you will be taken to the respective main screen of the selected function.

Operation

Adjusting the volume

To adjust the overall volume, use the volume slider

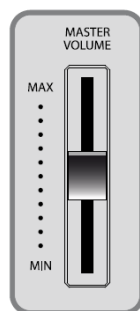

Choosing a Tone (Voice)

Press the key of the desired voice group. Now press the ENTER button (b) to display the voice list of this group. Select the desired tone using the arrow keys.

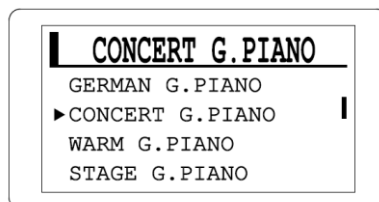
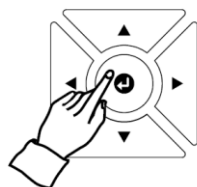
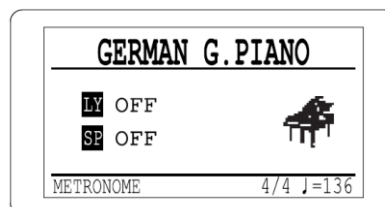
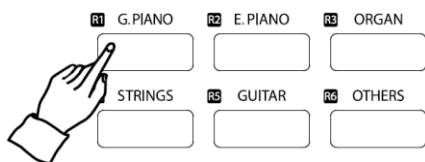

You can also scroll through the tones using the ◀ or ▶ keys without selecting a group.

STEINMAYER

Voice-Liste

G.Piano	E.Piano	Organ
German G. Piano	Vintage E. Piano	Pipe Organ
Concert G. Piano	Modern E. Piano	E. Organ Gospel
Warm G. Piano	Bright E. Piano	E. Organ Jazz
Stage G. Piano	Clavinet	E. Organ Rock
Mellow G. Piano	Harpsichord	Accordion
Light Pop G. Piano	Vibraphone	
Honkytonk Piano	Synth Lead 1	
	Synth Lead 2	
Strings	Guitar	Others
Symphony Strings	Acoustic Guitar	Brass Section
Bright Strings	Steel Guitar	Big Band Brass
Brass Strings	Jazz Guitar	Synth Brass
Pizzicato Strings	Driven Guitar	French Horn
Synth Strings	Acoustic Bass	Trumpet Soloist
Slow Strings	Elec Bass	Flute Soloist
Violin Soloist		Orchestral Oboe
Cello Soloist		Clarinet
Choir Aha		Alto Sax
Vocal Ooh		Tenor Sax
		Drum Set
		SFX Set

For the Voices E. Organ Gospel, Jazz and Rock the Rotary-Effect is automatically activated.

Dual

Press the DUAL button to enter the Dual Mode. In this mode, you can combine multiple timbres in different ways. Pressing the DUAL button repeatedly will enter the different operating modes.

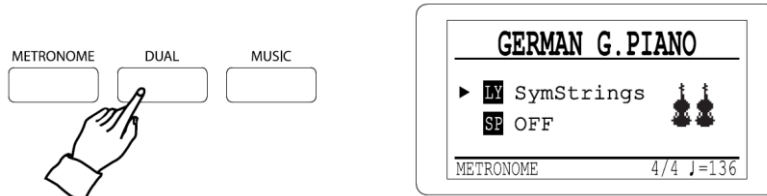

In Dual Mode you can choose from the following options:

DUAL mode	Layer / Split				Twin Piano	
Order in the menu	Layer	Layer+Split	Split	Off	Twin Piano	Off
LED color	white	pink	red	off	white	off
Display	LY	LY,SP	SP	-	+	-

Layer

Here two tones per key are played simultaneously.

First select the desired main voice (Main Voice).

Now press the DUAL button. The cursor in the display points to LY and the DUAL button lights in white color. Now select the desired second tone (Layer Voice) using the ◀ or ▶ keys.

By moving the cursor up and down, you can switch between the selection of the main and layer voice

The volume levels of both voices can be adjusted individually. See function menu.

Press the DUAL button three times to deactivate the mode.

Split

Here, the keyboard divides into two areas with different timbres. First, select the desired main voice for the right keyboard half.

Now press the DUAL button three times. The cursor on the display points to SP and the button lights in red.

Now select the desired second tone (split voice) for the left keyboard half using the ◀ or ▶ keys.

By moving the cursor up and down, you can switch between the selection of the main and split voices.

The volume levels of both voices can be adjusted individually. See function menu.

Press the DUAL button again to deactivate the mode.

Layer+Split

Layer and split function can be combined.

First, select the desired main voice for the right keyboard half.

Now press the DUAL button twice. The display shows the respective voice for LY and SP and the button lights in pink.

By moving the cursor up and down, you can switch between the selection of the main, layer and split voice. Now select the desired tone using the ◀ or ▶ keys.

The volume levels of the different voices can be adjusted individually. See function menu.

Press the DUAL button twice to deactivate the mode.

Move the split point

The split point defines the boundary between the left and right half of the keyboard. The split point can be chosen individually. See function menu. The default value for the split point is F # 3 (the third Fis from the left).

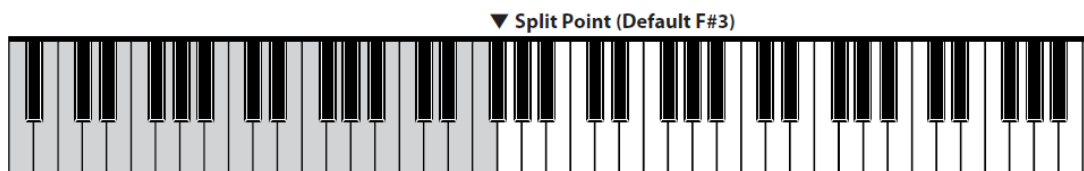

Twin Piano

This function divides the keyboard into two equal parts. Now two players can play in the same pitch at the same time.

The operation of the pedals is adapted to the split keyboard. The left pedal controls the sustain effect of the left keyboard half and the right pedal controls the sustain effect of the right keyboard half.

To be able to use this mode, you have to switch in the function menu in the category Controller in dual mode to the value TWIN. See function menu.

 **NOTE** If TWIN mode is selected, Split and Layer are no longer available.

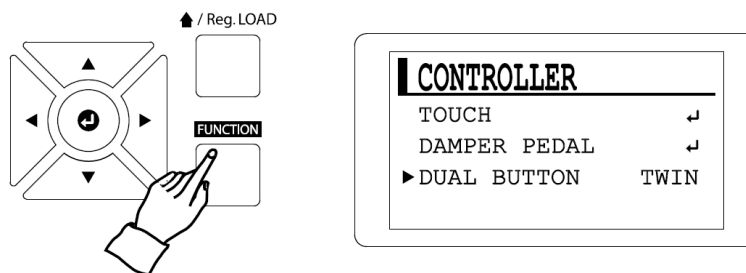

First select the desired tone.

Now press the DUAL button. The display will show the icon of the selected voice twice and the button will light in white.

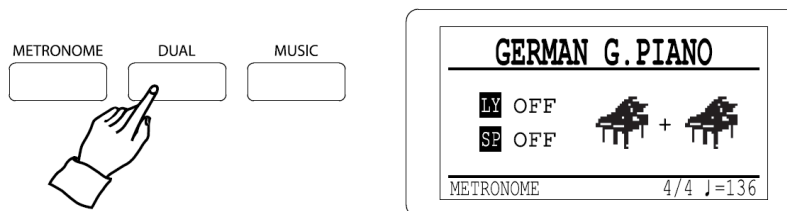

The keyboard is now split at Eb4.



Press the DUAL button again to deactivate the TWIN mode.

Metronome

Start / Stop

Press the METRONOME button to start the metronome.

Press the METRONOME button again to stop the metronome.

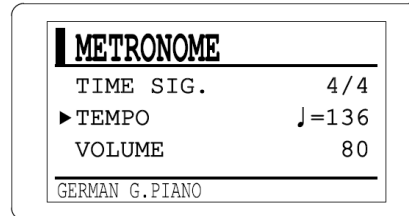
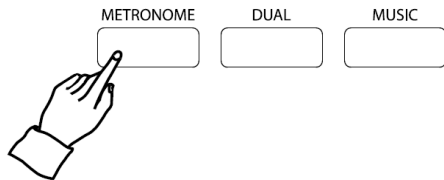

Metronome Settings

Press the METRONOME button to enter the metronome menu. Use the ▲ and ▼ keys to select the desired value.

Change the desired value using the ◀ or ▶ keys. Holding the key down for a longer time makes the change quicker. Press the ◀ and ▶ keys simultaneously to return to the default value.

The following values can be changed:

Display	Value Range	Default
TIME SIG.	2/2, 1/4, 2/4, 3/4, 4/4, 5/4, 6/4, 7/4, 6/8, 9/8, 12/8, 3/8, 7/8	4/4
TEMPO	40 - 250	120
VOLUME	50 - 100	80

TEMPO

The TEMPO button makes it easy to set the metronome speed.

Press the TEMPO button to access the speed display. Now change the value using the ◀ or ▶ keys.

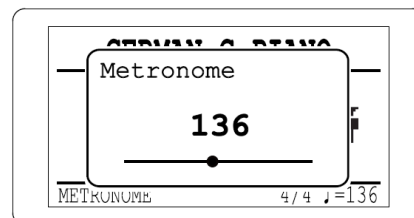
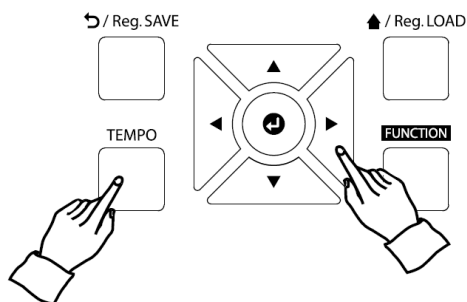

“Piano Assist” Function

In the Piano Assist function two different assistants can be selected. In Drum Player mode, you can be accompanied by a drum rhythm. In Piano Player mode, the instrument plays complicated left-hand chord patterns on its own, making it easier to play challenging piano pieces.

To start Piano Assist

To start Piano Assist, press the PIANO ASSIST button.

Now use the arrow keys ▲ ▼ to select between Drum Player and Piano Player and confirm the selection with the Enter key ↵.

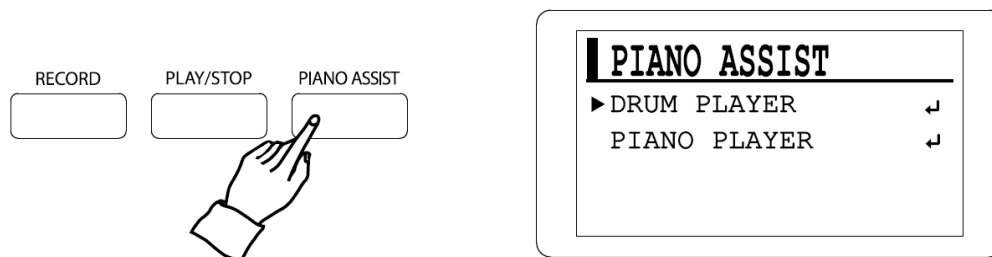

Drum Player

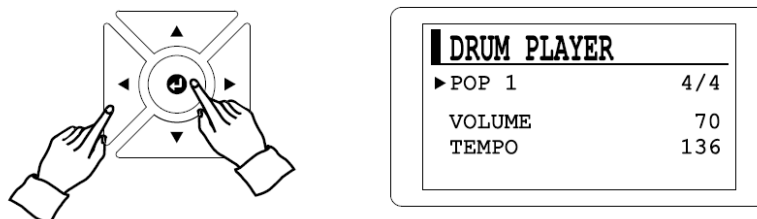

In Drum Player mode you can choose between many different drum rhythms.

Use the Cursor in the Drum Player menu window to select the drum rhythm. By pressing the ◀ or ▶ keys, you can choose between available rhythms. After selecting the rhythm, press the Enter key ↵ to go to the list of available rhythms.

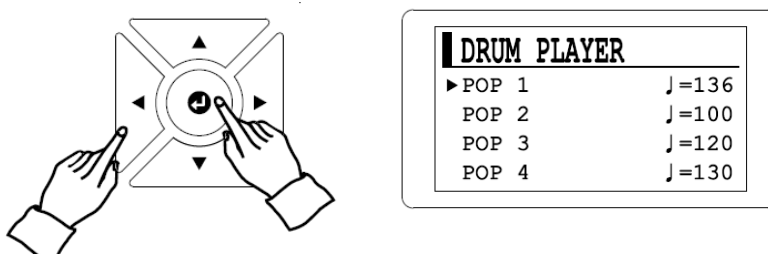

STEINMAYER

The following rhythms of drum accompaniment are available:

DRUM PLAYER							
01	Pop 1	11	Motown	21	Swing 1	31	Waltz 4
02	Pop 2	12	Slow Rock	22	Swing 2	32	March 1
03	Pop 3	13	Funk	23	Jazz 1	33	March 2
04	Pop 4	14	Latin 1	24	Jazz 2	34	Polka
05	Ballad 1	15	Latin 2	25	Bossanova1	35	Bluegrass
06	Ballad 2	16	Latin 3	26	Bossanova2	36	Country 1
07	Rock 1	17	Rhumba	27	Bossanova3	37	Country 2
08	Rock 2	18	Salsa	28	Waltz 1	38	Reggae
09	Shuffle1	19	Tango 1	29	Waltz 2	39	Chacha
10	Shuffle2	20	Tango 2	30	Waltz 3	40	Makarena

The drum player starts as soon as you press a key on the keyboard or the START / STOP key. Press START / STOP again to stop the drum player. Press the PIANO ASSIST button again to exit this mode.

Piano Player

In the Piano Player mode, you can choose between numerous accompanying characters, which facilitate the play of the left hand.

The operation of the Piano Player mode is analogous to the drum player.

You can choose between the following accompanying characters:

PIANO PLAYER			
01	Arpeggio 4/4	11	Boogie
02	Arpeggio 3/4	12	Waltz
03	Ballad	13	Skate Waltz
04	Slow Rock	14	Jazz Waltz
05	Polka	15	Beguine
06	March	16	Twist
07	Blues1	17	Jive
08	Blues2	18	Obladi
09	RocknRoll	19	Dixieland
10	Swing	20	Country

The piano player starts as soon as you play a chord in the left keyboard area.

The instrument now plays on its own the associated chord break of the selected accompanying figure. Press the START / STOP button to stop the piano player. Press the PIANO ASSIST button again to exit this mode.

STEINMAYER

Chord specification for the piano player

In Piano Player mode, it is necessary to specify the chord of the desired accompaniment character.

For this purpose, two methods can be used with this instrument:

Single Finger method

With the Single Finger method, chords can be specified with 1-3 fingers. Here, the root of a chord is enough to define a major triad. The keynote and the nearest left black key lead to a minor triad. The root note and the nearest left white key give a dominant seventh chord and the root note and the nearest left white and black keys a minor seventh chord.

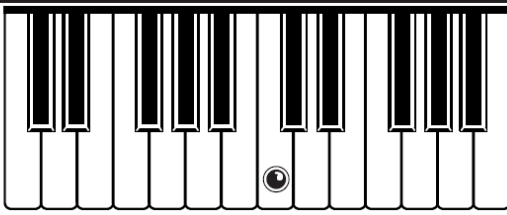
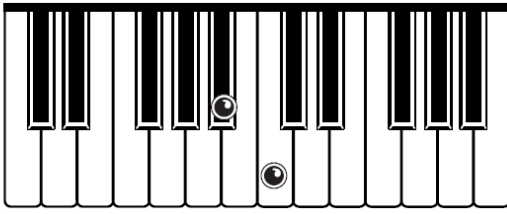
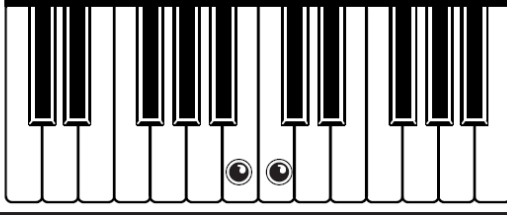
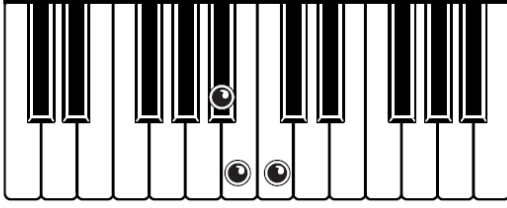
C	 A piano keyboard diagram showing the C major chord. The root note C is marked with a dot on the white key in the middle of the keyboard.
Cm	 A piano keyboard diagram showing the Cm minor chord. The root note C is marked with a dot on the white key in the middle of the keyboard, and the nearest left black key (Bb) is also marked with a dot.
C7	 A piano keyboard diagram showing the C7 dominant seventh chord. The root note C is marked with a dot on the white key in the middle of the keyboard, and the nearest left white key (B) is also marked with a dot.
C m7	 A piano keyboard diagram showing the Cm7 minor seventh chord. The root note C is marked with a dot on the white key in the middle of the keyboard, and the nearest left white key (B) and the nearest left black key (Bb) are both marked with dots.

STEINMAYER

Fingered

With the fingered method, it is possible to specify a chord by all chord tones involved. The advanced player can use this method to reproduce more complicated chords.

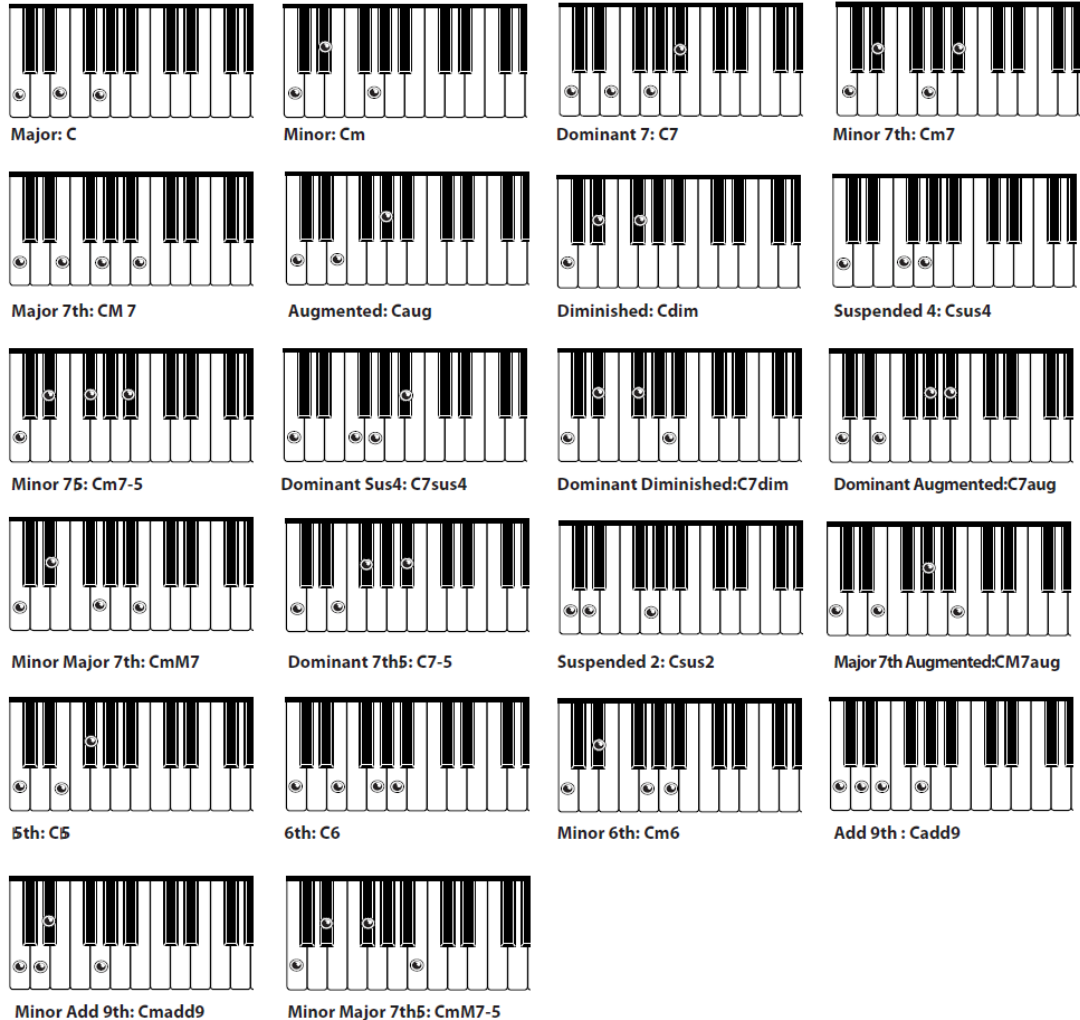

Select the Method

In the Piano Assist window, you can choose between two settings for chord recognition. Press PIANO ASSIST and then select Piano Player. Move the cursor to the ACCOMP menu dialog and use the ◀ or ▶ keys to select between MULTI.F and FINGERED. In MULTI.F mode, the piano recognizes both chord input methods (Single Finger + Fingered). This setting is the default setting.

Further settings

You can select additional settings in the Piano Assist screen. Press PIANO ASSIST and then select Piano Player. Move the cursor to the desired menu dialog and use the ◀ or ▶ keys to change the tempo or volume of the Piano Player.

Display	Value Range	Default	Restriction
VOLUME	0 - 100	70	
TEMPO	40 - 250	rhythm dependent	
ACCOMP	MULTI.F / FINGERED	MULTI.F	Only in the piano player

“Record” Function

Recording and playback

Press the RECORD button to go to the screen for recording.

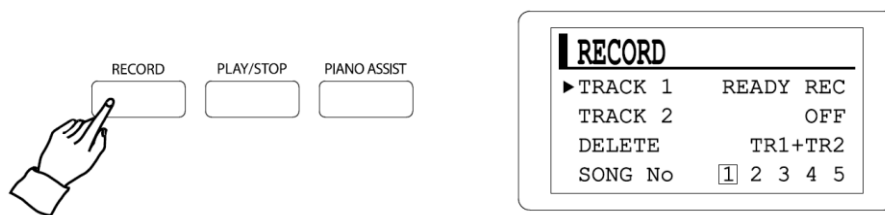

Track 1 is now ready for recording.

Use the ◀ or ▶ keys to toggle the status of the track between READY REC (record-ready) and OFF (inactive). If Track 1 is inactive, the status of track 2 is automatically changed to READY REC.

Press START / STOP or play the keyboard to start recording.

To stop recording, press the START / STOP button again. The status of the track will now change to PLAY.

To play the recorded track, press the START / STOP button again.

To record a second track simultaneously with playback, use the cursor to change the status of Track 2 to READY REC. Start recording by pressing the START / STOP button or playing on the keyboard.

To add a second track without hearing the recording of Track 1, go with the cursor to TRACK 1 and set its status with the ◀ or ▶ keys on MUTE.

A track occupied by a recording cannot be dubbed. If you would like to replace this track, delete the current recording via the menu dialog DELETE.

Here you can select with the arrow keys which track should be deleted (TR1, TR2 or TR1 + TR2).

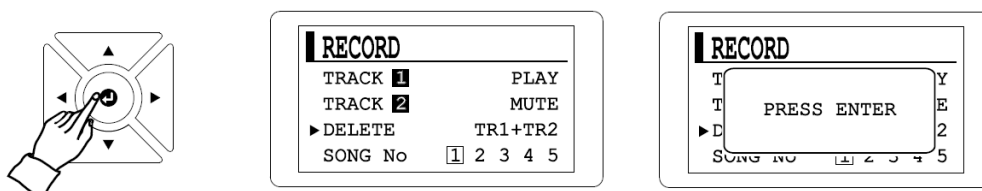

The piano has 5 memory slots for 2 tracks each. These can be selected in the SONG No menu dialog using the ◀ or ▶ keys.

Press the RECORD button again to exit the RECORD menu.



If no key is pressed for a long time during recording, recording will stop automatically.

The recording capacity per track is 4500 notes. If this number is exceeded, the recording stops automatically.

If you want to use the metronome while recording, start the metronome before recording. The metronome will not be recorded.

The piano has an internal memory. The recorded tracks are not lost when switching off the piano.

Recording with Piano Assist

The piano can also record your playing with Piano Assist. Just start the Piano Assist function before recording. The recording can only be done on Track 1 in READY REC status. Track 2 cannot save Piano Assist data. When changing to Track 2 or already assigned Track 1, the Piano Assist function will be switched off automatically.

Music Databank

The instrument contains various music data which can be used for practicing or simply for listening.

You can also play music from a USB stick (not included in scope of delivery) on the piano. The supported file formats are SMF and MP3.

Press the MUSIC button to go to the corresponding selection menu.

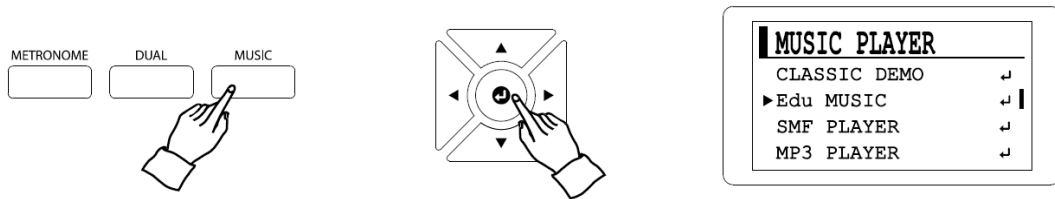

Navigate with the cursor to the desired menu item and confirm with Enter.

Classic Demo includes 50 classic demo songs.

Edu MUSIC includes an etude collection of some famous composers.

By confirming with the Enter button you will get to the respective operating menu. Press Enter again to go to the selection in the list.

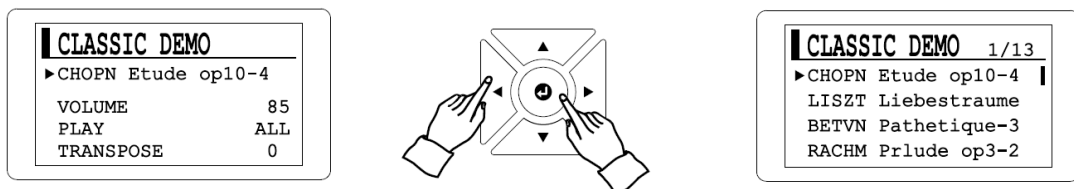

Press the START / STOP button to play the desired track.

In the operating menu, different parameters are available for modification. Navigate with the cursor to the desired parameter. This allows you to change the volume (VOLUME) and pitch (TRANSPOSE) of a song. In the PLAY menu dialog, you can select whether all songs should be played one after the other, only one song once or one song repeatedly. For Edu Music rehearsals, the speed and part (left, right or left and right hands) can also be selected for playback.



USB-Player

The piano can play music data from a USB stick (not included in the scope of delivery). The supported file formats are SMF and MP3.

The instrument only supports USB flash drives with FAT32 format.

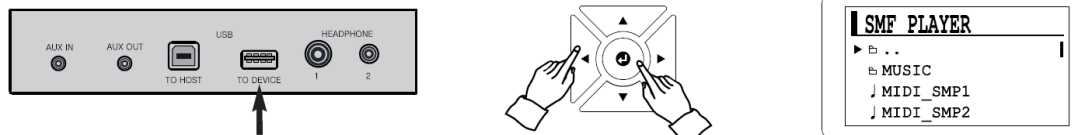
Press the MUSIC button and navigate the cursor to SMF (if you want to play standard MIDI files from the stick), MP3 (if there is MP3 data on the stick) or VP (if you want to play Advanced MIDI Files).



Navigate with the cursor to the desired file. Where stands  for a folder and  for the respective music file. Selecting  . . takes you to the higher-level folder.

Start the selected track using the START / STOP button.

In the operating menu, different parameters are available for modification. Navigate with the cursor to the desired parameter and confirm with Enter. This allows you to change the volume (VOLUME) of a song. In the PLAY menu dialog, you can select whether all songs should be played one after the other, only one song once or one song repeatedly.

Registration Memory

Saving a Registration

The instrument has five registration memory banks, each with six registration memories (R1-R6). These allow you quick access to preferred settings.

To save the current status of your piano's settings, press and hold the Reg.SAVE button and one of the six registration buttons (R1-R6).

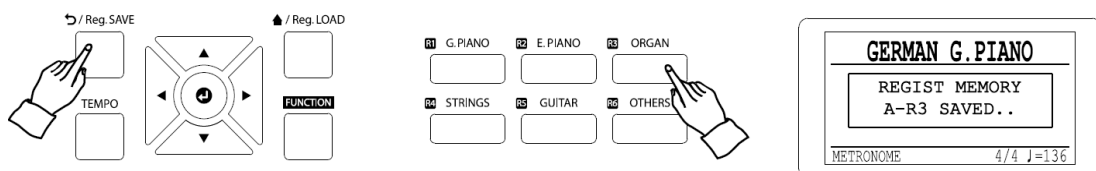

 **NOTE**: If memory data already exists on the selected registration memory location, this data will be overwritten.

Calling up a Registration

To recall the settings stored in a Registration Memory location, press and hold the Reg.LOAD button and one of the six Registration buttons (R1-R6).

Changing the Registration Memory Bank

To switch to another Registration Memory bank, use the menu dialog REGIST BANK in the SYSTEM category of the function menu. There are 5 Memory banks (A-E) available. See function menu.

BrainCare

The instrument has a separate BrainCare mode. To get into this operating state, turn off the instrument. Now press and hold the FUNKTION key and switch on the instrument. Hold down the FUNKTION key until the instrument is started in secured BrainCare mode.

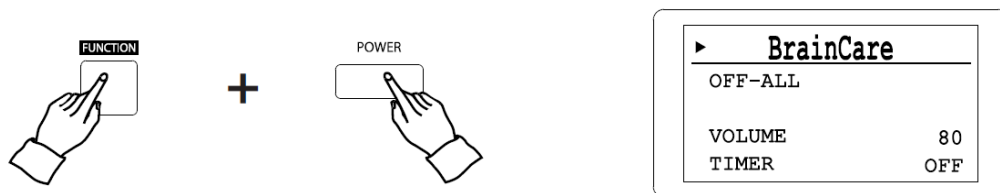

 **NOTE** There are no piano functions available in BrainCare mode.

In this operating mode, you can choose from different categories of background noise atmosphere with timer function.

These categories can be combined with each other. For example, as a sleeping aid you can underlay a relaxing piano piece with the sound of the sea and automatically stop playing the sound after 30 minutes.

With the cursor position next to BrainCare you can switch between the modes BrainCare (10 Presets), Binaural Beats, White Noise and Healing Music using the ◀ or ▶ keys.

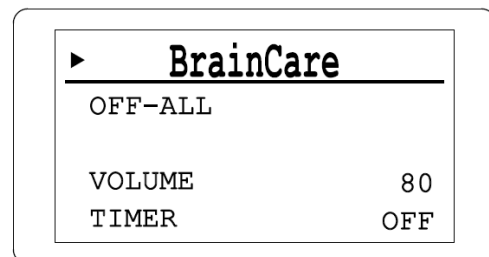

Move the cursor down to select between OFF-ALL (no sound from this section) and different background noises using the ◀ or ▶ keys.

STEINMAYER

Move the cursor to the position VOLUME to adjust the volume of this section with the ◀ or ▶ keys.

Move the cursor to the TIMER position to set the timer duration using the ◀ or ▶ buttons (range: 10 min – 240 min). The instrument automatically turns off after the timer expires.

<div style="border: 1px solid black; padding: 5px; width: fit-content; margin: auto;"> <p style="text-align: center;">BrainCare</p> <p>▶PRESET 01</p> <p>Study</p> <p>VOLUME 80</p> <p>TIMER OFF</p> </div> <p style="text-align: center;">Preset</p>	<div style="border: 1px solid black; padding: 5px; width: fit-content; margin: auto;"> <p style="text-align: center;">Binaural Beats</p> <p>▶[01] ALPHA WAVE 1</p> <p>Relaxation</p> <p>VOLUME 30</p> <p>TIMER OFF</p> </div> <p style="text-align: center;">Binaural Beats</p>	<div style="border: 1px solid black; padding: 5px; width: fit-content; margin: auto;"> <p style="text-align: center;">White Noise</p> <p>▶[01] WHITE NOISE</p> <p>Study</p> <p>VOLUME 50</p> <p>TIMER OFF</p> </div> <p style="text-align: center;">White Noise</p>	<div style="border: 1px solid black; padding: 5px; width: fit-content; margin: auto;"> <p style="text-align: center;">Healing Music</p> <p>▶[01]LSZT Liebestrum</p> <p>Meditation</p> <p>VOLUME 50</p> <p>TIMER OFF</p> </div> <p style="text-align: center;">Healing Music</p>
--	--	--	--

To return to Standard mode and exit BrainCare mode, turn the instrument off and start it again by simply pressing the POWER button.

BrainCare List

Healing Music			
Display	Type	Composer	Title
LSZT Liebestrum	Meditation	F. Liszt	Liebesträume S.541 No.3
SATI Gymnpdi 1e	Meditation	E. Satie	Gymnopedie 1ere
BTVN Monlight-1	Meditation	L. V. Beethoven	Sonate No.14 'Moonlight' - 1. Adagio sostenuto
SCHM Traumerei	Meditation	R. Schumann	Traumerei from Kinderszenen
CHPN Nct Op27-2	Meditation	F. Chopin	Nocturne Op.27 No.2
BTVN PathetiQ-2	Healing	L. V. Beethoven	Sonate No.8 'Pathetique' - 2. Adagio cantabile
TCSK Seasns-Oct	Healing	P. Tchaikovsky	The Seasons - X. October 'Autumn song'
MNDL Sprng Sng	Healing	F. Mendelssohn	Spring song
CHPN Noct Op9-2	Healing	F. Chopin	Nocturne Op.9 No.2 in - Andante
CHPN Noct Op9-1	Healing	F. Chopin	Nocturne Op.9 No.1 in - Larghetto
CHPN Bld Op23-1	Healing	F. Chopin	Ballade No.1
CHPN Wlz Op64-2	Healing	F. Chopin	Waltz Op.64 No.2
BRMS WlzOp39-15	Relaxation	J. Brahms	Waltz Op.39 No.1
DBSY Arabesque	Relaxation	C. Debussy	Arabesque No.1
DBSY Clair d In	Relaxation	C. Debussy	Suite bergamasque 3. Clair de lune

BrainCare Preset		Binaural Beats		White Noise	
Display	Type	Display	Type	Display	Type
PRESET 01	Study	ALPHA WAVE 1	Relaxation	WHITENOISE	Study
PRESET 02	Study	ALPHA WAVE 2	Relaxation	VACUUM	Study
PRESET 03	WorkingStress	ALPHA WAVE 3	Relaxation	FAN NOISE	Study
PRESET 04	WorkingStress	BETA WAVE 1	Working Stress	JET CAVIN	Study
PRESET 05	Relaxation	BETA WAVE 2	Working Stress	GALAXY SHIP	Study
PRESET 06	Relaxation	BETA WAVE 3	Working Stress	FOR SLEEP	Sleep
PRESET 07	Sleep	GAMMA WAVE 1	Study	FOR SLEEP 2	Sleep
PRESET 08	Sleep	GAMMA WAVE 2	Study	CRINKLE	Sleep
PRESET 09	Meditation	GAMMA WAVE 3	Study	TAPING	Sleep
PRESET 10	Meditation	DELTA WAVE 1	Deep Sleep	RIVER FLOW	Meditation
		DELTA WAVE 2	Deep Sleep	SEA WAVES 1	Meditation
		DELTA WAVE 3	Deep Sleep	SEA WAVES 2	Meditation
		THETA WAVE 1	Meditation	CRICKETS	Meditation
		THETA WAVE 2	Meditation	RAIN	Meditation
		THETA WAVE 3	Meditation	SINGING BOWL	Meditation

Function menu

Numerous settings can be made on the instrument with the function menu. This menu is divided into six subgroups. The operation within the groups takes place in the same way.

Press the FUNCTION button to enter the function menu.

Use the ▲ and ▼ keys to select the desired menu dialog and confirm your selection with the Enter button ↵.

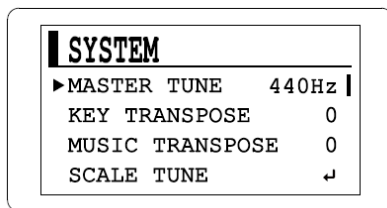
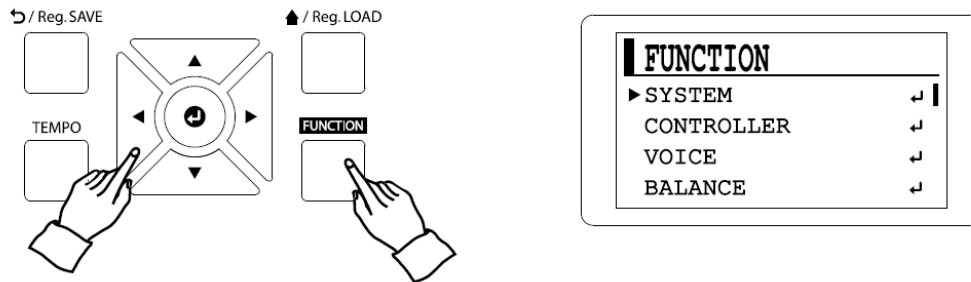

In the selected menu dialog, use the ▲ and ▼ keys to navigate to the desired value and change it using the ◀ or ▶ keys. If the symbol ↵ is displayed instead of a value, you must enter another submenu before you can change the value by pressing the Enter button.

The six subgroups are:

SYSTEM for basic system settings	page 25
CONTROLLER for settings for the keyboard or pedals	page 27
VOICE for the settings for timbres and effects	page 28
BALANCE for volume settings	page 30
MIDI for all MIDI-related settings	page 31
BLUETOOTH for using Bluetooth	page 31

The various setting options can be found in the following lists.

STEINMAYER

System

Menu dialog	Sub-menu-point	Standard	Range	Description
MASTER TUNE		440	415-465 (Hz)	The tuning of the instrument can be adjusted in steps of 1Hz to other instruments.
KEY TRANSPOSE		0	-12 - +12 (semitone)	The instrument can be tuned in semitone steps.
MUSIC TRANSPOSE		0	-12 - +12 (semitone)	The tuning of the Demo and Edu songs can be changed in semitone steps.
SCALETUNE	BASS NOTE TYPE	C EQUAL TEMPERAMENT	C-B Equal, Pure Major, and 7 more	<p>Many western instruments use the equal tuning scale. To play old or Arabic music authentically, other different tuning methods can be chosen.</p> <p>Equal tuning: Common tuning scale</p> <p>Pure Major / Pure Minor: strictly follows the overtone series of a defined root note.</p> <p>Pythagorean: Based on fifths and octaves, but destabilizes thirds.</p> <p>MeanTone: This system defuses the third-octave problem.</p> <p>Werckmeister / Kirnberger: These systems combine Pythagorean and MeanTone, each key has its own character.</p> <p>Arabic1 / Arabic2: For traditional Arabic music.</p>
REGISTER BANK		A	A-E	Select the Register bank here.

STEINMAYER

KEEP SETTING		OFF	On/OFF	In the ON position, all settings of the piano are retained for the next start.
AUTO POWER-OFF		30	Off/30/60/ 120/240 min	When not in use, the piano will turn itself off after a certain period of time to save power.
LCD KONTRAST		0	-20 - +20	Adjust the contrast of the display here. The set value also applies at the next start.
RESET			Yes/No	Resets all values and parameters to their factory settings (except LCD Contrast and Auto Power-Off).

Controller

Menu dialog	Sub-menu-point	Standard	Range	Description
TOUCH	CURVE	NORMAL3	FIXED/ SOFT1/2/3/ NORMAL1/2/3/ HARD 1/2/3	<p>Here you set the touch sensitivity of the instrument.</p> <p>FIXED: All notes are played equally loud regardless of the touch strength.</p> <p>NORMAL: Simulates the touch sensitivity of an acoustic grand piano.</p> <p>SOFT: Recommended for players with a weak touch strength. Even with a light touch relatively loud sounds are played.</p> <p>HARD: Recommended for players with a strong touch strength. This setting provides a wider dynamic range.</p>
	FIXED VELOCITY	80	20-127	With the FIXED dynamics setting, you can adjust here the volume of the notes played.
DAMPER PEDAL	LINEAR	ON	ON/OFF	This feature is also called a half pedal.
	DEPTH	NORMAL	LIGHT/ NORMAL/ HEAVY	Controls the strength of the pedal effect.
	MAIN	ON	ON/OFF	Activates the pedal function for the MAIN voice.
	LAYER	ON	ON/OFF	Activates the pedal function for the LAYER voice.

STEINMAYER

	SPLIT	ON	ON/OFF	Activates the pedal function for the SPLIT voice.
DUAL BUTTON		LY/SP	LY/SP TWIN	Controls how the DUAL function works as a layer / split or TWIN function.

Voice

Menu dialog	Sub-menu-point	Standard	Range	Description
PIANO ACOUSTIC	STRING RESO	60	0-100	In addition to the sound of each played string, the acoustic piano has a unique string resonance phenomenon caused by sound interference between the piano strings. This function allows you to set the string resonance volume.
	DAMPER RESO	80	0-100	When you play the damper pedal on an acoustic piano, in addition to playing the notes, you will hear certain strings of the piano reverberate. This is called damper resonance and is a natural reverberation that occurs in the piano body. This function allows you to set the damper resonance volume.
	CABINET RESO	ON	ON/OFF	In addition to the damper and string resonance, an acoustic piano has a cabinet resonance. With this function you can adjust the cabinet resonance. Speaker resonances represent the resonances of the strings without dampers

STEINMAYER

				(G6 C8) and the resonances delivered by the piano frame. When using REVERB, the cabinet sound effect is not applied, so REVERB should be off. This feature applies only to the MAIN voice.
	HAMMER SOUND	30	0-100	The acoustic piano creates sound by striking its strings with hammers. This parameter controls the volume of the physical sound of the hammers when they hit the strings.
	STRETCH TUNE	ON	ON/OFF	When tuning an acoustic piano, the lower strings are lowered a bit and the high strings are tuned slightly higher to compensate for the difference in frequency of the overtone harmonics, which depends on the tension and stiffness of the strings.
REVERB	TYPE	ROOM3	OFF/ ROOM1/2/3/ HALL1/2/3/ STAGE1/2/3	Choose from 9 reverb types.
	VOICE	65	0-100	Individual adjustment of the reverb content.
	PIANO ASSIST	65	0-100	
	DEMO/Edu MUSIC	65	0-100	
FX	TYPE	OFF	OFF/ CHORUS/ PHASER/ TREMOLLO/ ROTARY	Selection of effect types.
	DEPTH	80	0-100	Regulates the effect proportion.

STEINMAYER

SPLIT POINT		F#3	C2-C6	Sets the split point.
OCTAVE	MAIN	0	-1 - +1	Adjusts the octave setting.
	LAYER	0	-1 - +1	
	SPLIT	0	-1 - +1	
BRILLIANCE		0	-50 - +50	Controls the brilliance of the piano sound.

Balance

Menu dialog	Sub-menu-point	Standard	Range
MAIN	100	0 - 100	Volume Main-Voice
LAYER	70	0 - 100	Volume Layer-Voice
SPLIT	100	0 - 100	Volume Split-Voice
METRONOME	80	50 - 100	Volume Metronome
PIANO ASSIST	70	0 - 100	Volume Piano-Assist
DEMO/ EduMusic	85	0 - 100	Volume Demo und Edu Music Songs
SMF/VP Player	70	0 - 100	Volume MIDI-File-Player
MP3 Player	50	0 - 100	Volume MP3-Player
BLUETOOTH	50	0 - 100	Volume Bluetooth-Audio
AUX IN	50	0 - 100	Volume AUX-In

MIDI

Menu dialog	Sub-menu-point	Standard	Range	Description
LOCAL CONTROL		ON	ON/OFF	Local-OFF Setting for using the piano as a MIDI controller.
MIDI OUT	MAIN	CH01	CH01-CH16	Selects the send channel for the MAIN voice.
	LAYER	CH02	CH01-CH16	Selects the send channel for the LAYER voice.
	SPLIT	CH03	CH01-CH16	Selects the send channel for the SPLIT voice.
	NOTE OFF VEL	ON	ON/OFF	Setting for the use of NOTE OFF Velocity.

Bluetooth

Menu dialog	Sub-menu-point	Standard	Range
PAIRING	ON	ON/OFF	Switch the pairing mode active or inactive.
VOLUME	50	0-100	Volume setting for Bluetooth audio.

Bluetooth

This instrument supports Bluetooth audio and Bluetooth MIDI connections.

Bluetooth Audio

The default is PAIRING ON. Thus, immediate pairing is possible. Activate Bluetooth on the smart device (smartphone, tablet or similar) which you want to connect to the piano. Select the piano from the list of available Bluetooth devices displayed on your smart device. Once pairing is complete, you can hear the music you play on your smart device through the speakers of the piano.

Bluetooth-MIDI

With the PAIRING-ON status selected, you can also pair your piano with MIDI-enabled applications on your smart device. To do this, select "BLE" as the MIDI device in the MIDI-enabled application.

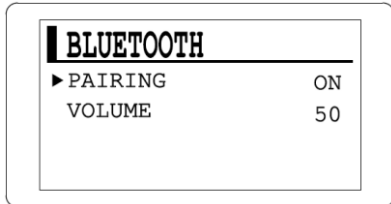

 **NOTE** If there are connection problems, check in the function menu whether the pairing status is ON.

Switch off the Bluetooth function of your Smart Device and start it again.

Check if there is already an automatic pairing with another device.

MIDI Chart

Function		Recognized	Transmitted	Remark
Basic Channel	Default	ALL	1-3	
Mode	Default	OMNI OFF, POLY	OMNI OFF, POLY	
Note ON/OFF	9nH kk w	O	O	#kk:note ON (0-127) #vv:velocity (1-127)
Pitch Bender	EnH bi bh	O	O	Maximum swing +/- 1 tone
Control Change	00 BnH 00H cc	O	X	Bank Select
	01 BnH 01H cc	O	X	Modulation Wheel
	05 BnH 05H cc	O	X	Portamento Time
	06 BnH 06H cc	O	X	Data Entry
	07 BnH 07H cc	O	X	Volume
	10 BnH 0AH cc	O	X	Pan Out
	11 BnH 0BH cc	O	X	Expression
	64 BnH 40H cc	O	O	Damper Pedal
	65 BnH 41H cc	O	X	Portamento ON/OFF
	66 BnH 42H cc	O	O	Sostenuto Pedal
	67 BnH 43H cc	O	O	Soft Pedal
	80 BnH 80H wv	O	X	Reverb Prog.(vv=00H-70H)
	81 BnH 51H wv	O	X	Chorus Prog.
	91 BnH 5BH wv	O	O	Reverb Send Level
	93 BnH 5DH wv	O	O	Chorus Send Level
	120 BnH 78H 00H	O	X	All Sound Off
121 BnH 79H 00H	O	X	Reset All Controller	
123 BnH 7BH 00H	O	X	All Notes Off	
126 BnH 7EH 00H	O	X	Mono On	
127 BnH 7FH 00H	O	X	Poly On	
Program Change	CnH PP	O	O	Sounds/Drum Set List
System Exclusive	General MIDI Reset	X	X	

O:Yes, X:No

STEINMAYER

GM-Voice

(only with MIDI connection)

GM #	VOICE	GM #	VOICE
001	Grand Piano 1	065	Soprano Saxophone
002	Grand Piano 2	066	Alto Saxophone
003	Grand Piano 3	067	Tenor Saxophone
004	Honky Tonk	068	Baritone Saxophone
005	Electric Piano 1	069	Oboe
006	Electric Piano 2	070	English Horn
007	Harpsichord	071	Bassoon
008	Clavinet	072	Clarinet
009	Celesta	073	Piccolo
010	Glockenspiel	074	Flute
011	Music Box	075	Recorder
012	Vibraphone	076	Pan Flute
013	Marimba	077	Bottle Blow
014	Xylophone	078	Shakuhachi
015	Tubular Bell	079	Whistle
016	Dulcimer	080	Ocarina
017	Electric Organ 1	081	Square
018	Electric Organ 2	082	Sawtooth
019	Electric Organ 3	083	Calliope
020	Pipe Organ	084	Chiffer
021	Reed Organ	085	Charang
022	Accordion	086	Solo Vox
023	Harmonica	087	Fifths
024	Bandonion	088	Bass Lead
025	Nylon Guitar	089	Fantasia
026	Steel Guitar	090	Warm Pad
027	Jazz Guitar	091	Poly Synth
028	Clean Guitar	092	Space Vox
029	Muted Guitar	093	Bow Glass
030	Drive Guitar	094	Metal Pad
031	Lead Guitar	095	Halo Pad
032	Harmonic Guitar	096	Sweep Pad
033	Acoustic Bass	097	Ice Rain
034	Finger Bass	098	Sound Track
035	Pick Bass	099	Crystal
036	Fretless Bass	100	Atmosphere
037	Slap Bass 1	101	Brightness
038	Slap Bass 2	102	Goblin
039	Synth Bass 1	103	Echo Drop
040	Synth Bass 2	104	Star Theme
041	Violin	105	Sitar
042	Viola	106	Banjo
043	Cello	107	Shamishen
044	Contra Bass	108	Koto
045	Tremolo Strings	109	Kalimba
046	Pizzicato Strings	110	Bagpipe
047	Harp	111	Fiddle
048	Timpani	112	Shanai
049	Strings	113	Tinkle Bell
050	Slow Strings	114	Agogo
051	Synth Strings 1	115	Steel Drum
052	Synth Strings 2	116	Wood Block
053	Choir Aahs	117	Taiko
054	Voice Oohs	118	Melody Tom
055	Synth Voice	119	Synth Drum
056	Orchestra Hit	120	Reversed Cymbal
057	Trumpet	121	Guitar Noise
058	Trombone	122	Breath Noise
059	Tuba	123	Sea Shore
060	Muted Trumpet	124	Birds
061	French Horn	125	Telephone
062	Brass Section	126	Helicopter
063	Synth Brass 1	127	Applause
064	Synth Brass 2	128	Gunshot

Percussion

(If two different effects are specified, they will react depending on the strength of the touch)

	Prog 59 SFX1 (SFX Set)
21 - A0	Low
22 - A#0	Bass Drum
23 - B0	Snare Drum Left Hand
24 - C1	Snare Drum Right Hand
25 - C#1	Bongo
26 - D1	Guiro
27 - D#1	Conga
28 - E1	Whistle
29 - F1	Sogo
30 - F#1	Cymbal
31 - G1	Castanets
32 - G#1	Triangle
33 - A1	Maracas
34 - A#1	Tambourine
35 - B1	Low/High (Woodblock Low/High)
36 - C2	Double Low C
37 - C#2	Jingle
38 - D2	Rocket Fire
39 - D#2	Jing
40 - E2	One
41 - F2	Two
42 - F#2	Scoundrel's Laugh
43 - G2	Three
44 - G#2	Cricket
45 - A2	Four
46 - A#2	Fairy
47 - B2	Five
48 - C3	Low C
49 - C#3	Samul Janggu L-1
50 - D3	Claps
51 - D#3	Samul Janggu L-2
52 - E3	Claps
53 - F3	Short/Long
54 - F#3	Samul Janggu M
55 - G3	Soft/Loud
56 - G#3	Samul Janggu R-1
57 - A3	Good/Very Good
58 - A#3	Samul Janggu R-2
59 - B3	Table Clock
60 - C4	Middle C
61 - C#4	Cuckoo
62 - D4	Bird
63 - D#4	Whistle Bird
64 - E4	Hen/Cackling

	Prog 59 SFX1 (SFX Set)
65 - F4	Chicks/Rooster
66 - F#4	Duck
67 - G4	Cat
68 - G#4	Dog
69 - A4	Goat
70 - A#4	Pig
71 - B4	Cow
72 - C5	High C
73 - C#5	Small Gong-1
74 - D5	Horse
75 - D#5	Small Gong-2
76 - E5	Horse Running
77 - F5	Frog/Frogs
78 - F#5	Splash
79 - G5	Swan+Bubble
80 - G#5	Comical Sound
81 - A5	Wolf
82 - A#5	Children's Laugh
83 - B5	Tiger
84 - C6	Double High C
85 - C#6	Samul Drum1
86 - D6	Bear
87 - D#6	Samul Drum2
88 - E6	Elephant
89 - F6	Bicycle
90 - F#6	Wall Clock+Pendulum
91 - G6	Bell
92 - G#6	Stream
93 - A6	Car
94 - A#6	Sea Waves/Waterfall
95 - B6	Train/Train+Whistle
96 - C7	Rain
97 - C#7	Forest
98 - D7	Wind
99 - D#7	Wind Chime
100 - E7	Thunder
101 - F7	Deep Sea
102 - F#7	The Sea
103 - G7	Bubble
104 - G#7	Fish Bubble
105 - A7	Robot
106 - A#7	Telephone
107 - B7	Helicopter/Siren
108 - C8	High

Trouble Shooting

If a malfunction occurs, please check the following causes of error.

Error	Cause	Solution
The piano does not turn on	<ol style="list-style-type: none"> 1.The power cord is not plugged in 2.The instrument is not turned on 3.The outlet has no power 	<ol style="list-style-type: none"> 1.Plug in the power cord properly 2.Turn on the instrument 3.Use another outlet
The piano does not emit sound from the speakers	<ol style="list-style-type: none"> 1.The volume is set to the lowest value 2.A headphone (adapter) is in the headphone jack 3.The power cord is not plugged in 	<ol style="list-style-type: none"> 1. Increase the volume setting 2.Remove the headphone (adapter) from the headphone jack 3.Plug the instrument into an electrical outlet
The volumes of the different voices are very different	The volume adjustment in the function menu is changed	Reset the volume levels in the function menu to the default values
The instrument emits noises	<ol style="list-style-type: none"> 1.There are devices with disturbing features (freezer, washing machine or similar) in the immediate vicinity 2.Objects on or near the instrument resonate with 3.The noise occurs only when using a headphone 	<ol style="list-style-type: none"> 1.Remove the piano from the vicinity of other electrical appliances (especially those with motors) 2.Remove resonant objects from the surroundings of the piano 3.Clean the headphone plug or replace the headphone
The instrument does not pass any sound through the AUX-OUT connector	<ol style="list-style-type: none"> 1.The volume is set to the minimum value 2.The connection cable is damaged 	<ol style="list-style-type: none"> 1. Increase the volume 2.Replace the connection cable

Product Specifications

Keyboard	touch-sensitive real wood hammer buttons
Touch-sensitivity	10 levels (Soft 1/2/3, Normal 1/2/3, Hard 1/2/3, Fixed)
Max. Polyphony	256
Voices	46 + 1 Drum-Set + 1 SFX-Set
Dual	Layer, Split, TwinPiano
DSP	9 Reverb, 4 Effect
Demo	50
Piano Assist	PianoPlayer 20, DrumPlayer 40
Record function	2 Tracks in 5 banks (4500 Note/Track)
Registration memory	5 banks with 6 memory slots each
Bluetooth	Bluetooth-Audio, Bluetooth-MIDI Bluetooth 5.0 Dual Mode, Class2 Frequency spectrum: 2.402 GHz to 2.480 GHz • Receive sensitivity: -90 dBm (2 Mbps EDR) • Output Power - BM62/64 Class 2: +2 dBm typical
BrainCare	10 Preset, 15 Binaural Beats, 15 White Noise, 15 Healing Music
Pedals	3 (Soft, Sostenuto, Sustain)
Half-pedal	Yes (right pedal)
Connections	AUX In/Out, USB to Host, USB to Device, 2x headphone (3,5mm+6,35mm), Pedal, Power supply
Speaker	(18,4cm x 12,7cm)x2 + (6,1cm)x2
Power consumption max.	66W
Supplied accessories	Power supply 24V, 2,75A, + inside

WEEE Declaration

(Waste of Electrical and Electronic Equipment)

Your product has been designed and manufactured using high quality materials and components that are recyclable and reusable. This symbol means that electrical and electronic equipment must be disposed of separately from household waste at the end of their service life.

Please dispose of this device at your local municipal collection point or at the recycling center.

Please help protect the environment in which we all live.

All specifications and appearance are subject to change without notice. All information was correct at the time of printing. Musikhaus Kirstein GmbH assumes no responsibility for the accuracy or completeness of the descriptions, photos or statements contained in this manual. Printed colors and specifications may vary slightly from the product. Products of Musikhaus Kirstein GmbH are distributed only through authorized dealers. Distributors and dealers are not representatives of Musikhaus Kirstein GmbH and are not authorized to legally bind Musikhaus Kirstein GmbH in any way, whether expressly or through conclusive action. This manual is protected by copyright. Any duplication, or any reprint, even in extracts, and any reproduction of the illustrations, even in altered condition, is only permitted with the written consent of the company Musikhaus Kirstein GmbH.

SIMPLIFIED EU DECLARATION OF CONFORMITY

Herewith Musikhaus Kirstein GmbH declares that the radio unit of Model is in compliance with the EU directive 2014/53/EU.

You can download the full EU declaration of conformity for this item under download link:

http://www.kirstein.de/docs/Konformitaetserklaerung/CE_Konformitaetserklaerung_00063251.pdf



Musikhaus Kirstein GmbH

Bernbeurener Str. 11

86956 Schongau – Germany

Telefon/Phone: 0049-8861-909494-0

Telefax/Fax: 0049-8861-909494-19

