

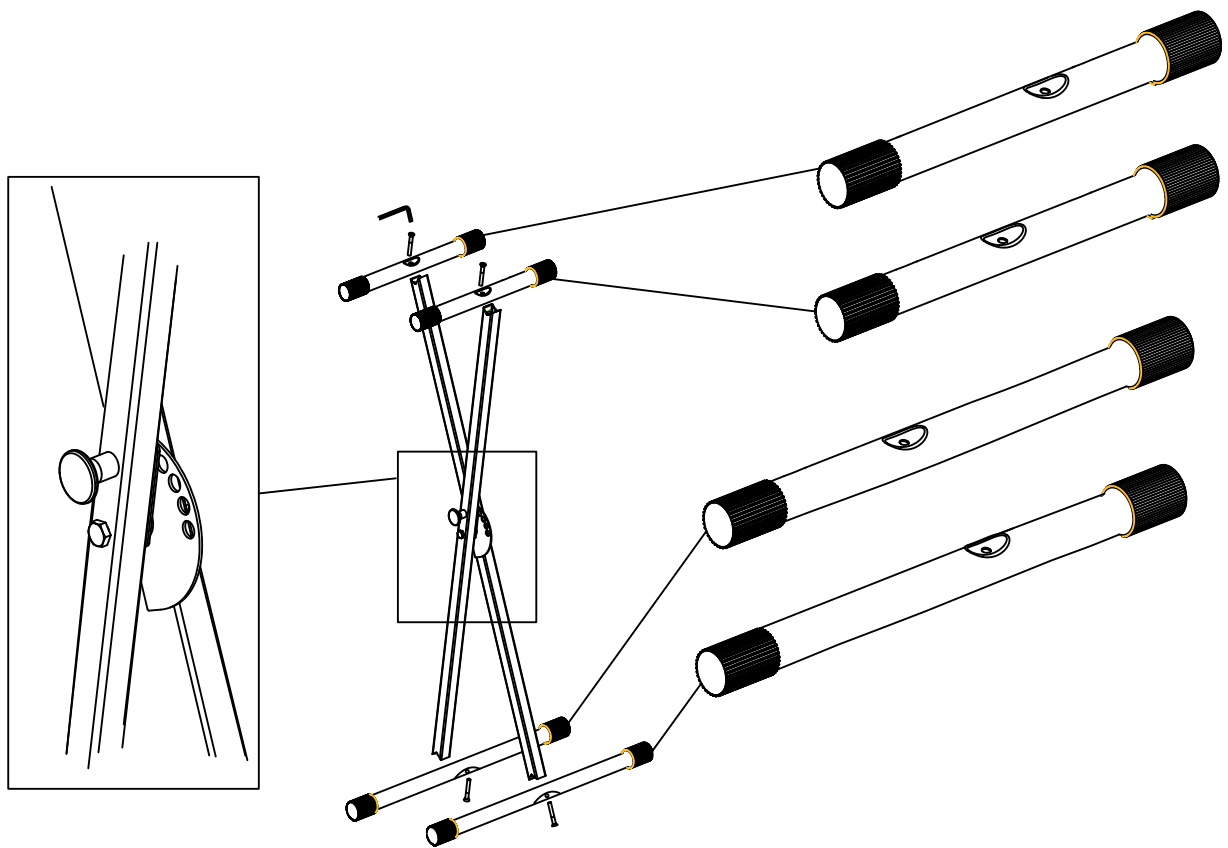

X-Keyboardständer einstrebig



 **KIRSTEIN.de**
We love music!

Musikhaus Kirstein GmbH
Bernbeurener Str. 11
86956 Schongau
www.kirstein.de

Art. 00009812 /00062730
Version 10/2019



KH-10

VORSICHTSMASSNAHMEN (BITTE SORGFÄLTIG DURCHLESEN). Kinder sollten beaufsichtigt werden, um sicherzustellen, dass sie dieses Produkt nicht als Spielzeug verwenden. Lassen Sie Kinder niemals unbeaufsichtigt mit dem Verpackungsmaterial spielen. Warnhinweise: Lesen Sie diese Anweisungen und bewahren Sie diese Anleitung auf. Verwenden Sie dieses Gerät nicht im Wasser. Vorsichtsmaßnahmen: Um Schäden am Produkt zu vermeiden, bringen Sie es nicht an Plätze mit hohen Temperaturen oder viel Staub, sehr niedriger oder hoher Luftfeuchtigkeit, legen Sie es nicht direkt neben eine Klimaanlage und vermeiden Sie direkte Sonneneinstrahlung. Wenden Sie im Umgang mit dem Produkt keinerlei Gewalt an. Ort: Setzen Sie das Produkt nicht den folgenden Bedingungen aus, um Verformungen, Verfärbungen oder größere Schäden zu vermeiden: Direktes Sonnenlicht, extreme Temperatur oder Luftfeuchtigkeit, übermäßig staubiger oder schmutziger Ort. Reinigung: Reinigen Sie das Produkt nur mit einem weichen, trockenen Tuch. Verwenden Sie keine Farbverdünner, Lösungsmittel, Reinigungsflüssigkeiten oder chemisch imprägnierte Wischtücher. Technische Änderungen und Änderungen im Erscheinungsbild sind vorbehalten. Alle Angaben entsprechen dem Stand bei Drucklegung. Für die Richtigkeit und Vollständigkeit der enthaltenen Beschreibungen, Abbildungen und Angaben übernimmt Musikhaus Kirstein GmbH keinerlei Gewähr. Abgebildete Farben und Spezifikationen können geringfügig vom Produkt abweichen. Musikhaus Kirstein GmbH - Produkte sind nur über autorisierte Händler erhältlich. Distributoren und Händler sind keine Handlungsbevollmächtigten von Musikhaus Kirstein GmbH und haben keinerlei Befugnis, die Musikhaus Kirstein GmbH in irgendeiner Weise, sei es ausdrücklich oder durch schlüssiges Handeln, rechtlich zu binden. Diese Bedienungsanleitung ist urheberrechtlich geschützt. Jede Vervielfältigung, bzw. jeder Nachdruck, auch auszugsweise, und jede Wiedergabe der Abbildungen, auch in verändertem Zustand, ist nur mit schriftlicher Zustimmung der Firma Musikhaus Kirstein GmbH gestattet.

WARNUNG: Achten Sie auf eine angemessene Lautstärke! Hören mit zu hohem Lautstärkepegel kann Ihr Gehör dauerhaft schädigen!



FUNKTION UND HANDHABUNG Der Kopfhörer kann mit allen handelsüblichen Abspielgeräten, wie CD-Playern, Stereoanlagen, mobilen Musik-Playern verwendet werden, welche über einen Kopfhörerausgang mit 3,5mm Stereo-Klinke verfügen. Sollte Ihre Soundquelle mit einem Kopfhörerausgang mit 6,3mm Stereo-Klinke ausgestattet sein, nutzen Sie den mitgelieferten Adapter (6,3mm zu 3,5mm Stereoklinkenbuchse).

WARTUNG: Ihr Gerät erfordert keine besondere Wartung. Wenden Sie sich im Falle einer Fehlfunktion an ein zugelassenes Servicecenter oder direkt an den Hersteller.

REINIGUNG: Verwenden Sie zur Reinigung ein fusselfreies, trockenes oder nur leicht angefeuchtetes Tuch.

TECHNISCHE DATEN: System: dynamischer Kopfhörer Stereo, Nennimpedanz: 32Ohm +/- 10%, Frequenzbereich: 20-20000Hz, Empfindlichkeit: 103dB S.P.L. bei 1kHz +/- 2%

WEEE-Erklärung (Waste of Electrical and Electronic Equipment) Ihr Produkt wurde unter Verwendung hochwertiger Materialien und Komponenten entwickelt und hergestellt, die recycelbar und wiederverwendbar sind. Dieses Symbol bedeutet, dass elektrische und elektronische Geräte am Ende ihrer Lebensdauer vom Hausmüll getrennt entsorgt werden müssen. Bitte entsorgen Sie dieses Gerät bei Ihrer örtlichen kommunalen Sammelstelle oder im Recycling-Center. Bitte helfen Sie mit, die Umwelt zu schützen, in der wir alle leben.



Musikhaus Kirstein GmbH, Bernbeurener Strasse 11, 86956 Schongau, Germany, [Tel:08861-909494-0](tel:08861-909494-0), info@kirstein.de



KH-10

PRECAUTIONS (PLEASE READ CAREFULLY). Children should be supervised to ensure that they do not use this product as a toy. Never allow children to play with the packaging material unsupervised. Warnings: Read these instructions and keep these instructions in a safe place. Do not use this appliance in water. Precautions: To avoid damage to the product, do not place it in places with high temperatures or a lot of dust, very low or high humidity, do not place it directly next to an air conditioner and avoid direct sunlight. Do not use force when handling the product. Location: Do not expose the product to the following conditions to avoid deformation, discoloration or major damage: Direct sunlight, extreme temperature or humidity, excessively dusty or dirty place. Cleaning: Only clean the product with a soft, dry cloth. Do not use paint thinners, solvents, cleaning fluids or chemically impregnated wiping cloths. We reserve the right to make technical changes and changes in appearance. All information is correct at the time of printing. Musikhaus Kirstein GmbH accepts no liability for the accuracy and completeness of the descriptions, illustrations and information contained herein. Colors and specifications shown may differ slightly from the product. Musikhaus Kirstein GmbH products are only available through authorized dealers. Distributors and dealers are not authorized agents of Musikhaus Kirstein GmbH and have no authority to legally bind Musikhaus Kirstein GmbH in any way, whether expressly or by implication. These operating instructions are protected by copyright. Any duplication or reprinting, even in part, and any reproduction of the illustrations, even in modified form, is only permitted with the written consent of Musikhaus Kirstein GmbH.

WARNING: Ensure an appropriate volume level! Listening at too high a volume level can permanently damage your hearing!



FUNCTION AND HANDLING The headphones can be used with all commercially available playback devices such as CD players, stereo systems and mobile music players that have a headphone output with a 3.5mm stereo jack. If your sound source is equipped with a headphone output with a 6.3 mm stereo jack, use the supplied adapter (6.3 mm to 3.5 mm stereo jack).

MAINTENANCE: Your appliance does not require any special maintenance. In the event of a malfunction, contact an approved service center or the manufacturer directly.

CLEANING: Use a lint-free, dry or slightly damp cloth for cleaning.

TECHNICAL DATA: System: dynamic stereo headphones, nominal impedance: 32Ohm +/- 10%, frequency range: 20-20000Hz, sensitivity: 103dB S.P.L. at 1kHz +/- 2%

WEEE declaration (Waste of Electrical and Electronic Equipment) Your product has been developed and manufactured using high-quality materials and components that are recyclable and reusable. This symbol means that electrical and electronic equipment must be disposed of separately from household waste at the end of its life. Please dispose of this appliance at your local municipal collection point or recycling center. Please help to protect the environment in which we all live.



Classic Cantabile

CPK-403

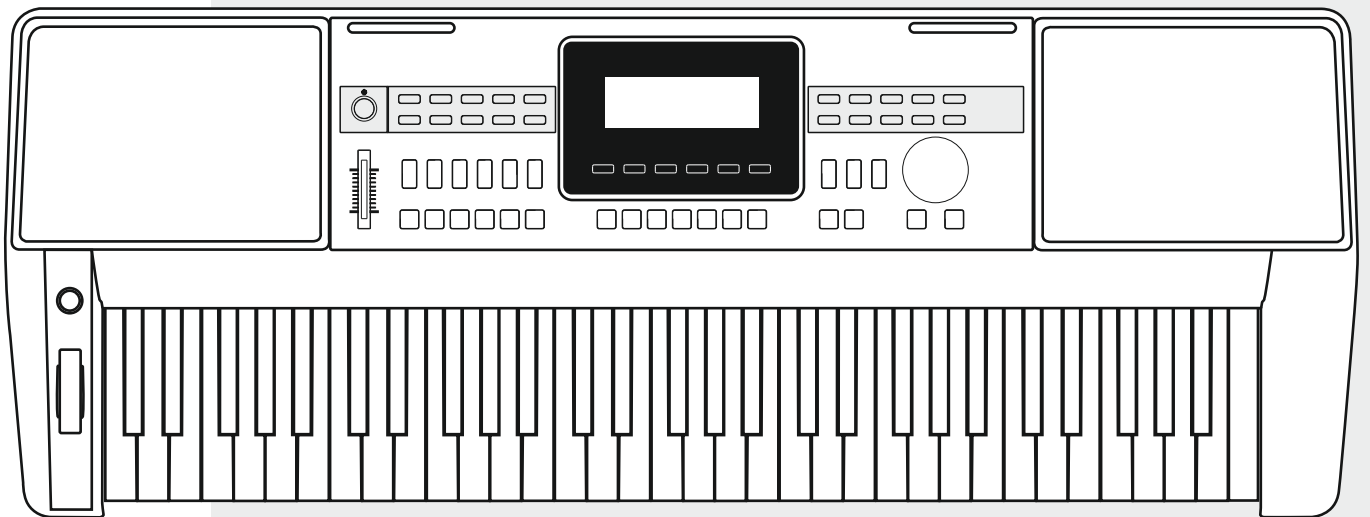

Owner's Manual

Version 07/2019

INFORMATION FOR YOUR SAFETY!

THE FCC REGULATION WARNING (for USA)

This equipment has been tested and found to comply with the limits for a Class B digital device, pursuant to Part 15 of the FCC Rules.

These limits are designed to provide reasonable protection against harmful interference in a residential installation. This equipment generates, uses, and can radiate radio frequency energy and, if not installed and used in accordance with the instructions, may cause harmful interference to radio communications. However, there is no guarantee that interference will not occur in a particular installation. If this equipment does cause harmful interference to radio or television reception, which can be determined by turning the equipment off and on, the user is encouraged to try to correct the interference by one or more of the following measures:

- Reorient or relocate the receiving antenna.
- Increase the separation between the equipment and receiver.
- Connect the equipment into an outlet on a circuit different from that to which the receiver is connected.
- Consult the dealer or an experienced radio/TV technician for help.

Unauthorized changes or modification to this system can void the user's authority to operate this equipment.

CAUTION

The normal function of the product may be disturbed by Strong Electro Magnetic Interference. If so, simply reset the product to resume normal operation by following the owner's manual. In case the function could not resume, please use the product in other location.

PRECAUTIONS

PLEASE READ CAREFULLY BEFORE PROCEEDING

Please keep this manual in a safe place for future reference.

Power Supply

Please connect the designated AC adaptor to an AC outlet of the correct voltage.

Do not connect it to an AC outlet of voltage other than that for which your instrument is intended.

Unplug the AC power adaptor when not using the instrument, or during electrical storms.

Connections

Before connecting the instrument to other devices, turn off the power to all units. This will help prevent malfunction and / or damage to other devices.

Location

Do not expose the instrument to the following conditions to avoid deformation, discoloration, or more serious damage:

- Direct sunlight
- Extreme temperature or humidity
- Excessive dusty or dirty location
- Strong vibrations or shocks
- Close to magnetic fields

Interference with other electrical devices

Radios and televisions placed nearby may experience reception interference. Operate this unit at a suitable distance from radios and televisions.

Cleaning

Clean only with a soft, dry cloth.

Do not use paint thinners, solvents, cleaning fluids, or chemical-impregnated wiping cloths.

Handling

Do not apply excessive force to the switches or controls.

Do not let paper, metallic, or other objects into the instrument. If this happens, unplug the AC adaptor from the wall outlet. Then have the instrument inspected by qualified service personnel.

Disconnect all cables before moving the instrument.

| | |
|---|---------------------|
| Panel & Display Description | |
| Front Panel..... | 4 |
| Rear Panel..... | 4 |
| LCD..... | 5 |
| Setup | |
| Power Supply..... | 6 |
| Setting a Music Stand..... | 6 |
| Using Sustain Pedal..... | 6 |
| Connections | |
| Connecting a pair of Headphones..... | 7 |
| Connecting an Audio Equipment..... | 7 |
| Connecting an MP3/CD Player..... | 7 |
| Connecting a Computer..... | 7 |
| Connecting a Microphone..... | 7 |
| | Quick Start |
| Power Switch and Master Volume | 8 |
| Playing Demo Songs | 8 |
| Playing Voices | 9 |
| Playing Styles | 9 |
| Playing Songs | 10 |
| Record | 10 |
| | Advanced Use |
| Playing Voices | |
| Selecting a Voice..... | 11 |
| Playing two voices simultaneously-DUAL..... | 11 |
| Playing Different Voices with Both hands-LOWER..... | 11 |
| Touch..... | 12 |
| Sustain..... | 12 |
| Pitch Bend..... | 12 |
| Modulation..... | 12 |
| Transpose..... | 12 |
| Octave..... | 13 |
| Piano mode..... | 13 |
| Metronome..... | 13 |
| Auto Accompaniment | |
| Play Auto Accompaniment(rhythm track only)..... | 14 |
| Play Auto Accompaniment(all tracks)..... | 14 |
| Accompaniment Sections..... | 15 |
| Playing Different Accompaniment Sections..... | 15 |
| Fade..... | 15 |
| Accompaniment Volume Control..... | 16 |
| Chord Fingering..... | 16 |
| Tempo..... | 17 |
| One Touch Setting..... | 17 |
| Harmony | |
| Play with harmony effect..... | 18 |
| Performance Assistant | |
| What's the performance assistant?..... | 19 |
| Enter the Performance Assistant..... | 19 |
| Guitar Mode..... | 19 |
| Playing in Guitar Mode..... | 20 |
| Piano Mode..... | 20 |
| Playing in Piano Mode..... | 21 |
| Exit the Performance Assistant..... | 21 |
| DSP | 22 |
| Mixer | 22 |
| Pedal Function | 23 |
| Function Menu | |
| Tune..... | 24 |
| KeySplit..... | 24 |
| Beat Type..... | 25 |
| Metronome Volume..... | 25 |
| Pedal Type..... | 25 |
| EQ Type..... | 25 |
| Reverb Type..... | 26 |
| Reverb Level..... | 26 |
| Chorus Type..... | 26 |
| Chorus Level..... | 27 |
| Harmony Type..... | 27 |
| MIDI IN..... | 28 |
| MIDI OUT..... | 28 |
| Auto Power Off..... | 28 |
| Performance Beat..... | 28 |
| Restore Factory Setting | 28 |
| Register Memory | |
| Registering the Panel Setting..... | 29 |
| Recalling the Registered Panel Settings..... | 29 |
| Selecting a Registration Bank..... | 29 |
| Song Album | 29 |
| Record | |
| Start Recording..... | 30 |
| Stop Recording..... | 30 |
| Playback Recording..... | 31 |
| Delete User Song..... | 31 |
| Song | |
| Listen to the songs..... | 32 |
| Song Control..... | 32 |
| Smart Learning System | |
| Smart Learning..... | 33 |
| Gold Star..... | 36 |
| Chord Dictionary | |
| DICT 1 (Chord Learning Mode)..... | 37 |
| DICT 2 (Chord Examining Mode)..... | 37 |
| MIDI | |
| What's MIDI?..... | 38 |
| Upload/Download Data from the Computer..... | 38 |
| Troubleshooting | 39 |
| Specifications | 40 |
| | Appendices |
| Voice List..... | 41 |
| Style List..... | 47 |
| Song List..... | 49 |
| Demo List..... | 50 |
| Album List..... | 51 |
| Chord List..... | 54 |
| MIDI Implementation Chart..... | 55 |

Panel & Display Description

Front Panel

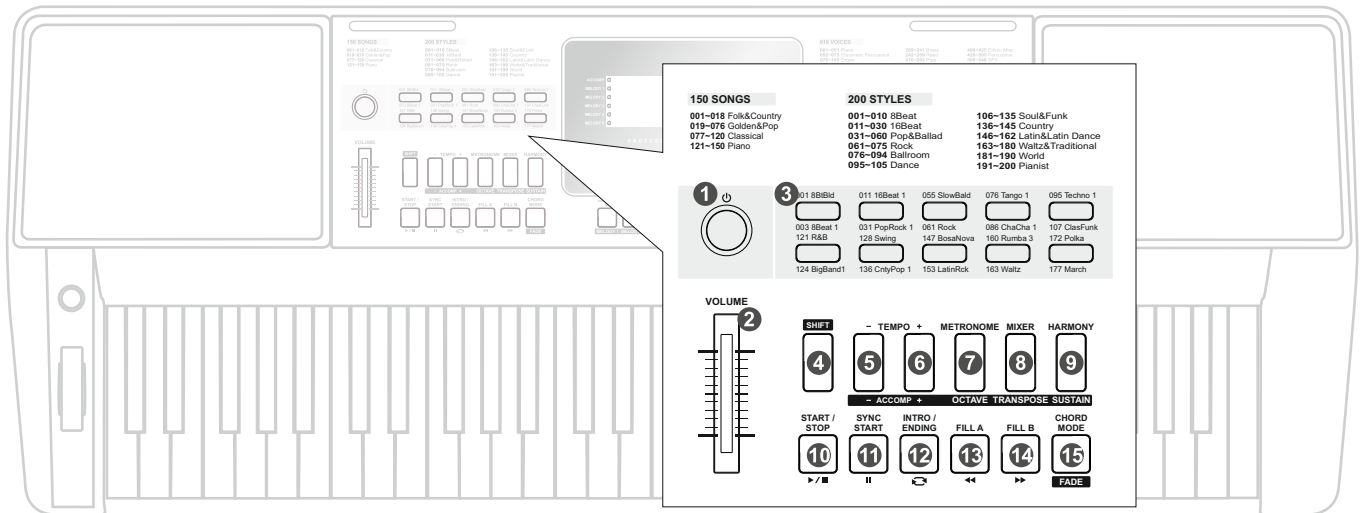

1. POWER SWITCH
Turn the Power on or off.

2. [VOLUME] Slider
Adjust the master Volume.

3. STYLE DIRECT SELECT BUTTON
Select a direct Style.

4. [SHIFT] button
Select the second function of some buttons.

- In Song Mode**
- 10. [▶/■] button**
Start or Stop playing the song.
 - 11. [⏸] button**
Pause or continue playing the song.
 - 12. [↺] button**
Set the beginning and ending location of loop to the current song.
 - 13. [◀◀] button**
Rewind the song.
 - 14. [▶▶] button**
Fast forward the song.

- In Style Mode**
- 10. [START/ STOP] button**
Start or Stop playing the style.
 - 11. [SYNC START] button**
Turn the Sync Start function on or off.
 - 12. [INTRO/ ENDING] button**
Play the Intro or Ending.
 - 13. [FILL A] button**
A Fill-in A plays.
 - 14. [FILL B] button**
A Fill-in B plays.

When the [SHIFT] button released
5~6. [TEMPO +]~ [TEMPO -] button
Adjust the current Tempo.

When the [SHIFT] button pressed
5~6. [ACCOMP +]~ [ACCOMP -] button
Adjust the ACCOMP volume.

7. [METRONOME] button
Turn the metronome on or off.

7. [OCTAVE] button
Enter the Octave setting.

8. [MIXER] button
Enter the Mixer menu.

8. [TRANPOSE] button
Enter the Transpose setting.

9. [HARMONY] button
Turn the Harmony effect on or off.

9. [SUSTAIN] button
Turn the Sustain function on or off.

15. [CHORD MODE] button
Enter the chord mode.

15. [FADE] button
Produce smooth Fade-ins or Fade-outs at the beginning or end of style playback.

Rear Panel

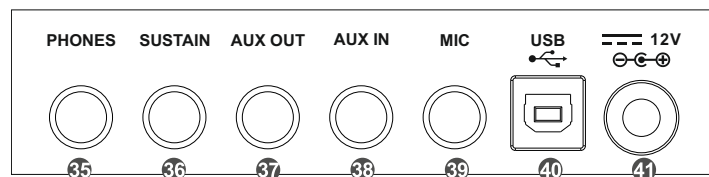

35. PHONE jack
Connect a pair of headphones.

38. AUX IN jack
Connect an external sound source, such as an MP3 or CD player.

40. USB terminal
Connect to a computer.

36. SUSTAIN jack
Connect a sustain pedal.

39. MIC jack
Connect a microphone.

41. DC 12V jack
Connect DC 12V power adaptor.

37. AUX OUT jack
Connect the audio equipment.

Panel & Display Description

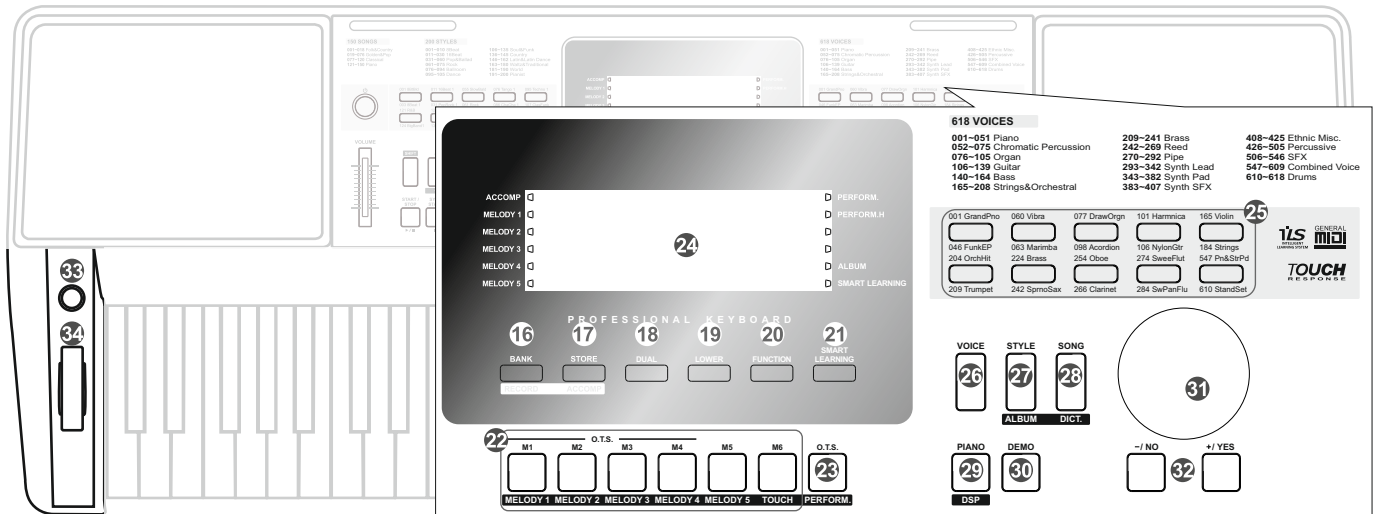

- | | | | |
|--|---|--|---|
| <p>18. [DUAL] button Turn the Dual function on or off.</p> <p>19. [LOWER] button Turn the Lower function on or off.</p> <p>20. [FUNCTION] button Enter the Function Mode.</p> <p>21. [SMART LEARNING] button Turn the Smart Learning function on or off.</p> <p>24. [LCD] Display the useful information while using this keyboard.</p> <p>25. VOICE DIRECT SELECT BUTTON Select a direct Voice.</p> | <p>26. [VOICE] button Switch to Voice Mode.</p> <p>30. [DEMO] button Switch to Demo Mode.</p> <p>31. DATA DIAL Slowly or quickly adjust the parameter value.</p> <p>32. [-/NO]/ [+YES] button Adjust parameter value.</p> <p>33. [MODULATION] button Apply a vibrato effect.</p> <p>34. [PITCH BEND] wheel Bend notes up or down.</p> | <p>When the [SHIFT] button Released</p> <p>16. [BANK] button Switch between Memories.</p> <p>17. [STORE] button Register the panel settings.</p> <p>22. [M1] ~ [M6] buttons Recall the registered panel settings. In O.T.S. mode, only M1-M4 are available.</p> <p>23. [O.T.S.] button Turn one touch setting on or off.</p> <p>27. [STYLE] button Switch to Style Mode.</p> <p>28. [SONG] button Enter the Song Mode.</p> <p>29. [PIANO] button Enter the Piano Mode.</p> | <p>When the [SHIFT] button Pressed</p> <p>16. [RECORD] button Enter the Record Mode.</p> <p>17. [ACCOMP] button Select the accompaniment track when recording.</p> <p>22. [MELODY 1] ~ [MELODY 5] buttons Select the melody track from melody 1 - melody 5 when recording. [TOUCH] button Turn the Touch Response on or off.</p> <p>23. [PERFORM.] button Turn the Performance Assistant function on or off.</p> <p>27. [ALBUM] button Turn the Album function on or off.</p> <p>28. [DICT.] button Enter the Chord Dictionary.</p> <p>29. [DSP] button Turn the DSP function on or off.</p> |
|--|---|--|---|

LCD

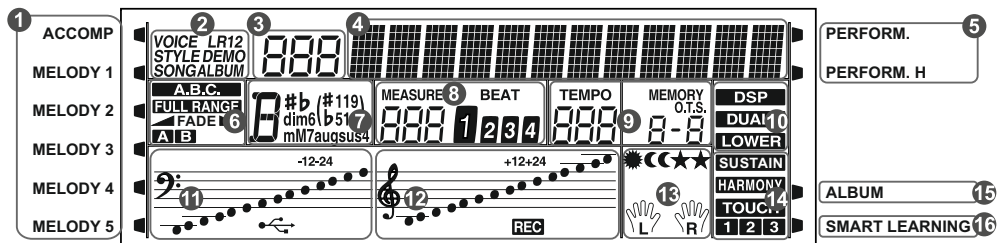

- | | | |
|---|--|---|
| <p>1. ACCOMP/ MELODY 1-5</p> <p>2. VOICE/ STYLE/ DEMO/ SONG/ ALBUM</p> <p>3. NUMBER</p> <p>4. CHARACTER</p> <p>5. PERFORMANCE ASSISTANT/ PERFORMANCE ASSISTANT HIGH</p> | <p>6. A.B.C. / FULL RANGE/ FADE/ ACCOMPANIMENT SECTION</p> <p>7. CHORD</p> <p>8. MEASURE/ BEAT</p> <p>9. TEMPO/ MEMORY/ O.T.S./ BANK</p> <p>10. DSP/ DUAL/ LOWER</p> <p>11. BASE CLEF/ USB</p> | <p>12. TREBLE CLEF/ RECORD</p> <p>13. GRADE LEVEL/LEFT HAND/ RIGHT HAND</p> <p>14. SUSTAIN/ HARMONY/ TOUCH (1-3)</p> <p>15. ALBUM</p> <p>16. SMART LEARNING</p> |
|---|--|---|

Setup

This section contains information about setting up your instrument and preparing to play. Please go through this section carefully before turning the power on.

Power Supply

You can power the instrument either by batteries or by power adaptor. Follow the instructions described below.

Using Batteries

6 pieces of AA (NO.5) or equivalent alkaline batteries must first be installed into the battery compartment.

1. Open the battery compartment cover located on the bottom cabinet of the unit.
2. Insert the batteries; carefully follow the polarity markings on the cabinet.
3. Replace the compartment cover, making sure that it locks firmly in place.

Note:

1. Do not mix old and new batteries.
2. Always use same types of batteries.
3. Always remove the batteries from the unit when it is not being used for an extended period of time.

Using Power Adaptor

1. First, please make sure that POWER ON/OFF switch of the instrument is set to OFF.
2. Connect the AC adaptor to the power supply jack.
3. Plug the AC adaptor into an AC outlet. And when turning the power OFF, simply reverse the procedure please. This will automatically cut off the battery power supply.

Note:

1. In the idle mode, the instrument will automatically shutdown in 30 minutes if you do not take any action on the instrument (Please refer to "Auto Power Off" for details).
2. When the keyboard is not in use or during thunderstorm, please disconnect the power for safety.

Setting a Music Stand

A music stand is supplied with the keyboard. You can easily attach it to the instrument by inserting it into the slots at the rear of the panel.

Using Sustain Pedal

When using a sustain pedal in playing, your performance will remain an elegant sustain with hands out of keys, which makes the performance more expressive and abundant. Plug an optional pedal into this jack and use it to switch sustain on and off.

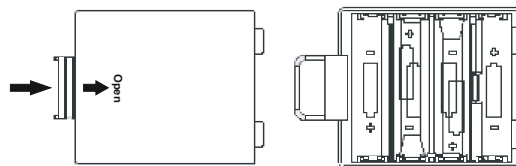

12V

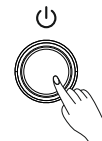
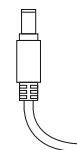

VOLUME

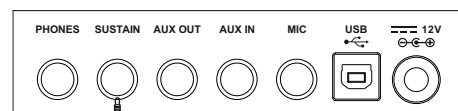
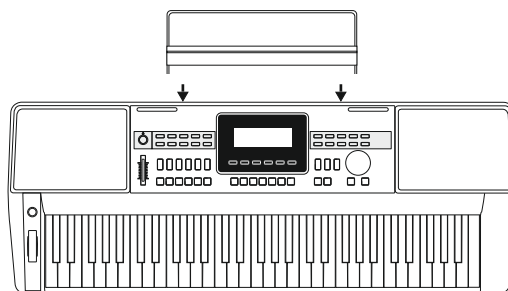
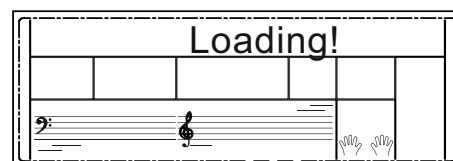
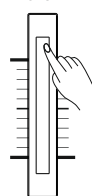

Connecting a pair of Headphones

1. A standard pair of stereo headphones can be connected to the PHONES jack for private practice or late-night playing.
2. The internal stereo speaker system is automatically shut off when a pair of head phones is plugged into this jack.

Note:

To avoid the risk of hearing loss when using headphones, please do not play the piano with a high volume level for a long time.

Connecting an Audio Equipment

The rear-panel AUX.OUT jack delivers the output of the instrument for connection to a keyboard amplifier, stereo sound system, a mixing console, or tape recorder. Use an audio cord to plug into the AUX.OUT jack located on the rear panel then plug the other end of the cord into AUX.IN of the amplifier.

Note:

To avoid damaging the speakers, please ensure that all connected audio equipments are turned off and the volume has been set to the minimum level before connecting the power and other devices.

Connecting an MP3/CD Player

Connect the audio output of an MP3/CD player or other audio source to the stereo AUX IN jack on the rear panel. The input signal is mixed with the instrument signal, allowing you to play along.

Connecting a Computer

The instrument can be connected to a computer by a USB cable. You can store your song playing to computer, or play the MIDI songs from computer.

Using a transverter between the piano MIDI IN /OUT terminal and the computer USB terminal can also transmit MIDI data.

Note:

1. Don't set the USB audio as input and output simultaneously on the computer software, or it may sound overlapped when play a note.
2. We recommend you using a USB 2.0 port to connect with your computer while you are using a USB 3.0 port and the instrument cannot work correctly.

Connecting a Microphone

By connecting a microphone, you can enjoy singing along with your keyboard performance or with Song playback (KARAOKE).

1. Before turning the power on, set the master volume to minor value.
2. Connect a microphone to the [MIC] jack.
3. Turn the power on. Adjust the master volume value while singing into the microphone.

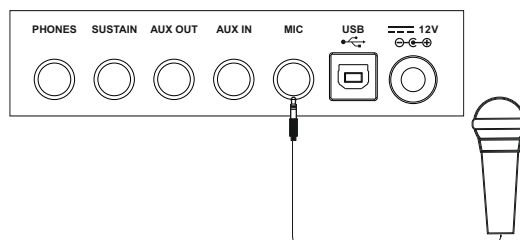
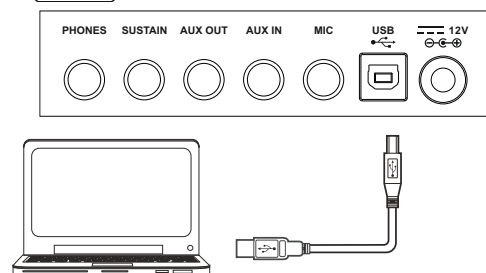
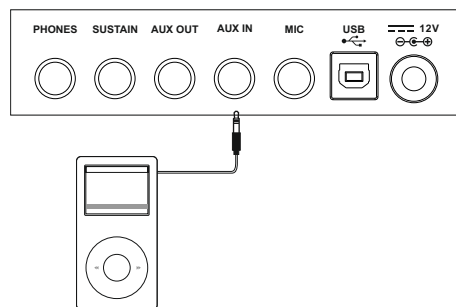
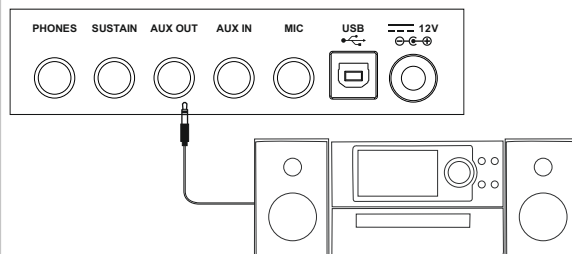
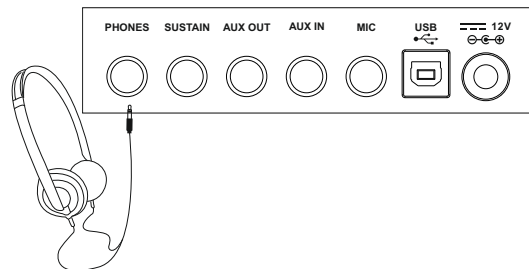

Power Switch and Master Volume

Power Switch

Before you switch your instrument on, please turn down the volume of instrument and the connected audio equipment first.

1. Firstly, please make sure you have correctly completed power connection.
2. Press POWER SWITCH, the LCD screen is lit, and displays "Loading!" on the screen, it indicates the instrument is powered on.

Note:

If the LCD display does not light up after you turned on the keyboard, please check the power supply.

Master Volume

Move the MASTER VOLUME slider upwards/ downwards to increase/ decrease the volume level. Adjust an appropriate value as you like.

Note:

The overall volume is too low, or no sound is heard. The master volume may set too low. Set it to an appropriate level with the [MASTER VOLUME] slider. Another reason could be the headphones are connected, disabling the speak output. Try to unplug the headphones.

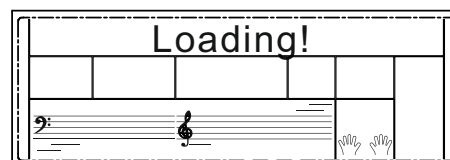

VOLUME

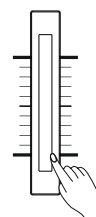

Playing Demo Songs

This instrument features 5 wonderful demos with different characters. (Please refer to Demo List.)

1. Press the [DEMO] button, enter the main interface of demo playing back, The LCD displays current demo number and name, meanwhile, all the demo songs will loop playing.
2. Use the data dial or the [+ /Yes] / [- /No] button to select a demo song.
3. Press the [START/STOP] button to stop playing and exit the demo mode.
Or you can press the [DEMO] button again.

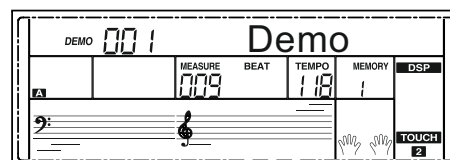

Playing Voices

The keyboard has 618 remarkably realistic built-in voices, including Piano, Woodwind, Saxophone, Drum Kits and many more. Please refer to Voice List.

1. Press the [VOICE] button.
Enter the Voice Mode. The LCD displays the current default voice name and number.
2. Select a Voice.
Use the data dial or the [+ / Yes] / [- / No] button to select the voice you want to play. You can also use the Voice Direct Button to select a voice. 2 direct voices for each button (upper & lower key).
3. Play the Voice.
You can play the keyboard and listen to the wonderful voice.

Note:

While changing a voice, pay attention to the rules. If you press the same button, the voice will be changed between the upper and lower key. When the upper/lower voice is on, and then you press another direct button, the corresponding upper/lower voice will be selected.

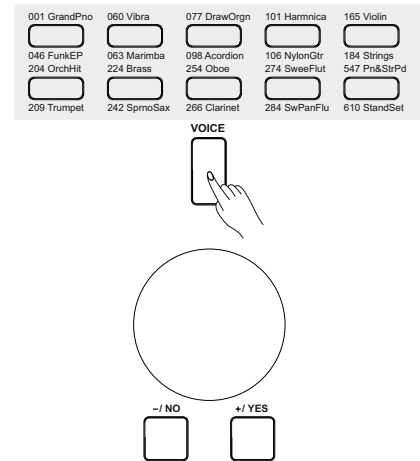

Playing Styles

The instrument features 200 styles in a variety of different musical genres. Try selecting some of the different styles (Please refer to the Style List) and playing with the auto accompaniment.

1. Press the [STYLE] button.
Enter the Style Mode. The LCD displays the current default style name and number.
2. Select a Style.
Use the data dial or the [+ / Yes] / [- / No] button to select the style you want to play. You can also use the Style Direct Button to select a style. 2 direct styles for each button (upper & lower key).
3. Play the Style.
Press the [START/STOP] button, directly start a rhythm playing.

Note:

While changing a style, please pay attention to the rules. If you press the same button, the style will be changed between the upper and lower key. When the upper/lower style is on, and then you press another direct button, the corresponding upper/lower style will be selected.

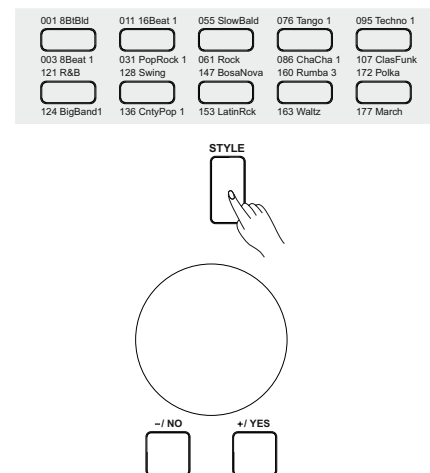

Playing Songs

This instrument has featured 150 preset songs, and each song can be practiced in Smart Learning mode.

1. Press the [SONG] button.
Enter the song selection mode. It will play all songs circularly.
2. Select a song.
Use the data dial or the [+ / YES] / [- / NO] button to select the song you want to play.
3. Press the [START / STOP] button.
Once you start playing a song, it will play current song repeatedly.
4. While stop playing a song, press any of [STYLE] or [VOICE] button, you can exiting the song mode.

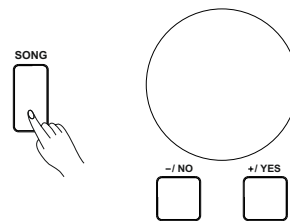

Record

You can record your performance and the accompaniment; this instrument can record up to 5 user songs.

1. Press and hold the [SHIFT] button, and then press the [BANK / RECORD] button.
Enter the song mode, you can use the data dial or the [+ / YES] / [- / NO] button to select a user song to be saved.
2. Press and hold the [SHIFT] button, and then press the [BANK / RECORD] button.
Enter the record standby mode, and you can select voice, style or other parameters to prepare for recording.
3. Press the [START / STOP] button or play a key on the keyboard to start recording.
4. When recording is in process, holding down [SHIFT] button and then press the [RECORD] button, it will stop recording and enter the Song play mode, and the current recorded song will play automatically in circle.

Note:

Press the [SONG] button to enter the song mode and it will play all songs circularly. Use the data dial, [+ / YES] or [- / NO] button can select a user songs (151~155). If there is no data in the selected user song, it will display "NoFile!" and stop playing.

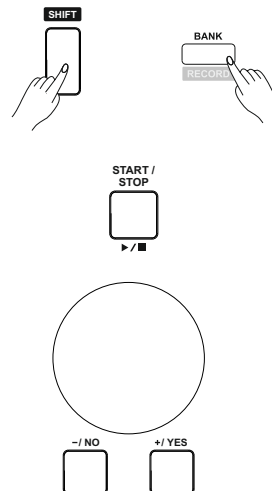

Playing Voices

The instrument features 618 build-in voices (Please refer to Voice List). In order to offer you a better performance experience, we programmed many useful effects which can be inserted while playing voices.

Selecting a Voice

1. Press the [VOICE] button or Voice Direct Button.
Enter the VOICE mode. LCD shows "VOICE R1" and the current voice name and voice number.
2. Select a voice.
Use the data dial, the [+ / YES] button, the [- / NO] button to select the voice you want to play. You can also use the Voice Direct Button to select a voice.
3. Play the voice.
You can play the keyboard and listen to the wonderful voice.

Note:

1. While changing a voice, pay attention to the rules: If you press the same button, the voice will be changed between the upper and lower key. When the upper/lower voice is on, and then you press another direct button, the corresponding upper/lower voice will be selected.
2. When the DUAL and LOWER function is on, you can press [VOICE] button repeatedly to choose the voice source. The corresponding LCD indicate will highlight between R1, R2, and L.

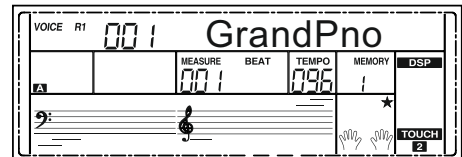
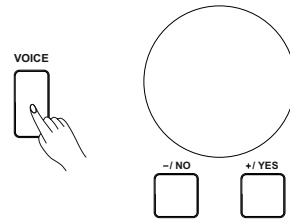

Playing two voices simultaneously-DUAL

This instrument has a dual voice function. This function is capable to enhance the delicacy of your music by playing two voices of musical instruments simultaneously; new combinations of voices and music could be created then. When the dual function is off, the voice indicated is VOICE 1, when the dual function is on; the voice indicated is VOICE 2.

1. In idle mode, press the [DUAL] button to turn dual function on. The LCD displays the current voice name and number, and the indicate "VOICE R 2" and "DUAL".
2. You can use the data dial or [+ / YES] / [- / NO] button to select the dual voice you want to play. You can also use the Voice Direct Button to select a voice.
3. Play the keyboard, and then you will hear two different voices are sounded simultaneously in a layer. It seems like two different instruments playing at the same time.
4. Press the [DUAL] button again to turn the dual function off.

Note:

When the keyboard has been split, only the right hand area will respond the dual voice, the left hand will not respond to it.

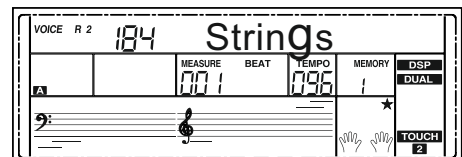
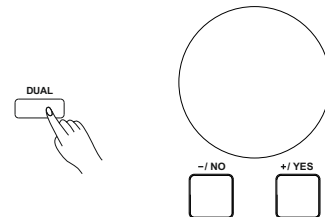

Playing Different Voices with Both hands-LOWER

The lower function splits the keyboard into right and left areas to create two different voices. The left section voice is lower voice. You can set the split point position as you like.

1. In idle mode, press the [LOWER] button to turn the lower function on.
The keyboard is split into two independent sections, and each section has its voice. The LCD displays the left hand voice name and number, and the indicate "VOICE L" and "LOWER".
2. You can use the data dial or the [+ / YES] / [- / NO] button to select the lower voice you want to play. You can also use the Voice Direct Button to select a voice.
3. Play the keyboard in different sections, and you will hear two different voices.
4. Press the [LOWER] button again to turn lower function off.

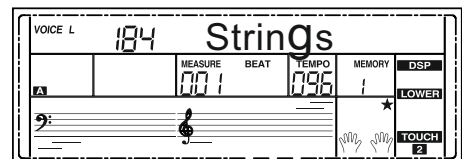
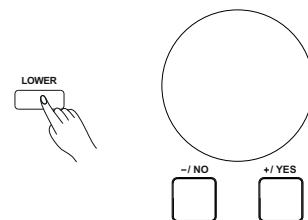

Split Point

The Point on the keyboard that separates voice L and voice R1/R2 is called the "split point". The split point is set to F#3(34) at the factory setting. However you can set this to any key you want. Refer to setting the split point.

Playing Voices

Touch

The instrument is equipped with a touch response feature that lets you dynamically and expressively controls the level of the voice with your playing strength just as on an acoustic instrument. The piano has 3 touch types to choose.

1. Holding down [SHIFT] button and then press [TOUCH] button to enter touch settings. The LCD displays the touch setting number. The default number is 2.
2. Choose a touch type. When the LCD displays touch setting, using [+ / YES] / [- / NO] or data dial or holding down [SHIFT] button, and then pressing [TOUCH] button can change touch type. Pressing [+ / YES] and [- / NO] buttons simultaneously will set touch value to default setting: 2(normal).
3. Turn the touch function off. If the value is set to OFF, that means no touch response to keyboard.

Sustain

1. Press and hold the [SHIFT] button and then press the [SUSTAIN] button to start sustain function. All notes will sustain even after releasing the keys.
2. To stop the sustain function, press the [SUSTAIN] button again.

Note:

If you want a better sustain effect, we recommend you using a sustain pedal. (Refer to pedal function for more details.)

Pitch Bend

Use the pitch bend wheel to bend notes up (roll the wheel away from you) or down (roll the wheel toward you) while playing the keyboard. The pitch bend wheel is self-centering and will automatically return to normal pitch when released. You can use the pitch bend wheel to imitate the guitar, violin, saxophone, urheen, suona and other instruments pitch bend effect, make your performance more vivid.

Modulation

The Modulation function applies a vibrato effect to notes played on the keyboard. This is applied to all the keyboard parts. Pressing the [MODULATION] button to add modulation effect and releasing [MODULATION] button to stop modulation effect. This modulation effect is very important to those performances with urheen, guitar, and violin these string instruments, make your performance more vivid.

Transpose

Transpose function allows the overall pitch of the instrument to be transposed up or down by a maximum of one octave in semitone increments.

1. Holding down [SHIFT] button, and then press [TRANPOSE] button to enter transpose settings. LCD displays the current transpose: xxx Transpos.
2. When LCD displays the current transpose, use [+ / YES] / [- / NO] or data dial to change transpose value. The max transposes is ± 12 semitones.
3. Press [+ / YES] and [- / NO] simultaneously will set the transpose value to its default setting: 000 Transpos.

Note:

1. If you want to play song in G key, you can set the transpose to -05 or 007, and then you can play the G scale using C scale keys.
2. Transpose setting is applied to all part of the music and keyboard.

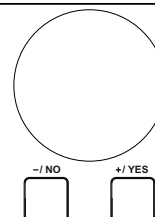
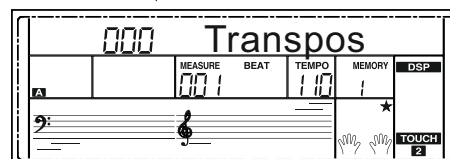
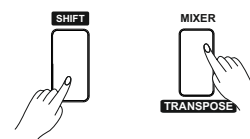
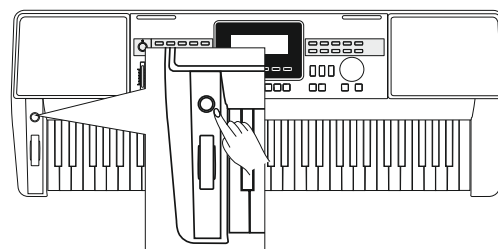
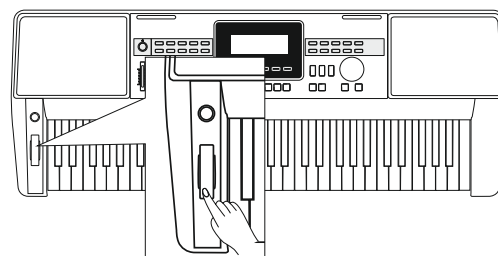
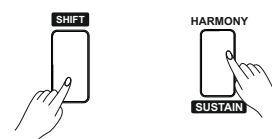
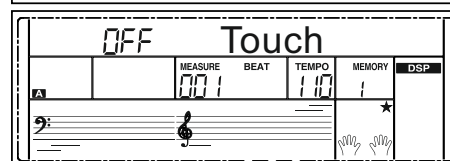
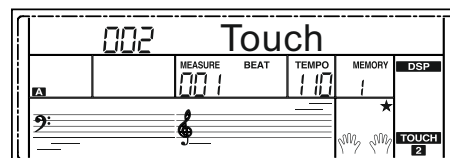
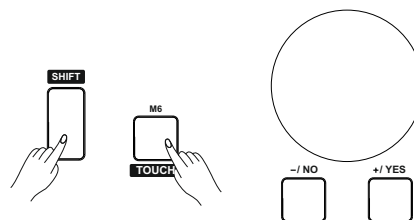

Octave

Octave function determines the relative octave setting for the keyboard-played voice R1, R2 and L.

1. Press and hold the [SHIFT] button and then press the [OCTAVE] button to select octave function menu. The LCD displays “xxx Octave”.
2. When LCD displays the current octave, use [+ / YES] / [- / NO] button or data dial to change octave value, adjustable range is: -1 ~ +1.
3. Press the [+ / YES] and [- / NO] buttons simultaneously to restore default setting: 000.

Note:

1. Some voices have a pitch limit which highest and lowest notes do not sound.
2. You can individually set the octave value of master voice, dual voice and lower voice. For example, in dual mode, allow the pitch of the keyboard to be shifted down or up in octave steps.

Piano mode

This function is to set the voice of the whole keyboard to piano instantly.

1. Press [PIANO] button can enter or exit piano mode.
2. In piano mode, the accompaniment control is the same to other mode. The accompaniment only plays the rhythm part.

Note:

In piano mode, the A.B.C. is automatically turned off.

Metronome

The metronome provides a click sound, giving you an accurate tempo guide when you practice, or letting you hear and check how a specific tempo sounds.

1. Press [METRONOME] button to start the metronome.
2. To stop the metronome, press the [METRONOME] button again. (The metronome type can be set in the function menu.)

Note:

1. The metronome and style can be started at the same time. If you start the metronome after the style stop playing, the beat type will be changed as metronome setting; if you start the metronome while the style is playing, the beat type will be changed as style setting.
2. You can record your performance while playing back the metronome. However, the metronome sound is not recorded.

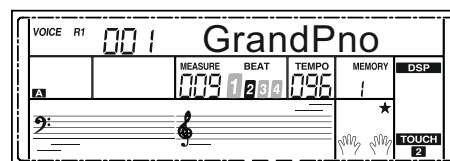
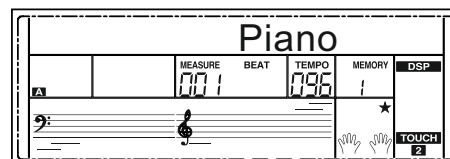
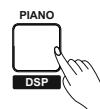
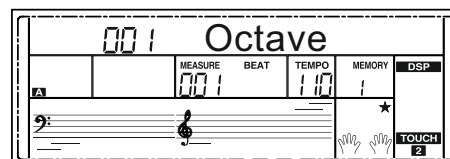

Auto Accompaniment

The auto accompaniment feature puts a full backing band at your fingertips. To use it, all you have to do is to play the chords with your left hand using your selected accompaniment style, and then the accompaniment will automatically play along, instantly following the chords you play. With auto accompaniment, even a solo performer can enjoy playing with the backing of an entire band or orchestra. This keyboard features 200 styles in a variety of musical genres. Try to select some of the different styles (refer to Style List) and enjoy the auto accompaniment feature.

Play Auto Accompaniment (rhythm track only)

1. Press [STYLE] button.
Enter the style mode. The "STYLE" icon on the left-top of the LCD will light up. The LCD displays the name and number of the current style.
2. Select a style.
Use the data dial or the [+ / YES] / [- / NO] button to select a style you want to play. Or you can use the Style Direct Button to make a quick selection.
3. Start playing a style.
Press the [START/STOP] button to start the rhythm tracks of the auto accompaniment. Also you can press [SYNC START] and then play any key to start the rhythm tracks of the auto accompaniment.
4. If you are ready to stop playing style, press the [START/STOP] again.

Note:

While changing a style, pay attention to the rules. If the same button has been pressed twice, the style will be swapped from one to another. When the upper/lower style is on, and you then press another direct button, the corresponding upper/lower style will be selected.

Play Auto Accompaniment(all tracks)

1. Turn the auto accompaniment on.
In style mode, you can press the [CHORD MODE] button to enter the "auto bass chord" (A.B.C.) mode. The keyboard is split into two sections. Left hand section is chord detect section. The "A.B.C." icon will light up. Now pressing any key in chord detect section(Sync Start status)you will hear the fantastic accompaniment.
Press [CHORD MODE] button again to enter "full range" mode. The "FULL RANGE" icon will light up. The whole keyboard is chord detect section.
2. Start the auto accompaniment.
You can press [SYNC START] button and then play a chord in chord detect section to start auto accompaniment of all tracks. When you change a chord, the accompaniment automatically changes.
You can also press [START/STOP] button to start auto accompaniment of rhythm track, then play a chord in chord detect section. It will start auto accompaniment of all tracks.

Note:

The instrument can save 10 user styles. To use your styles, you should use an optional Software to convert the style, and then use the USB cable to save the styles to the instrument.

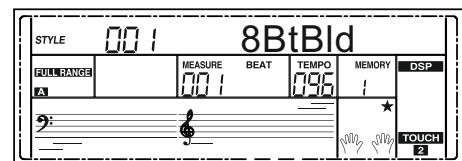
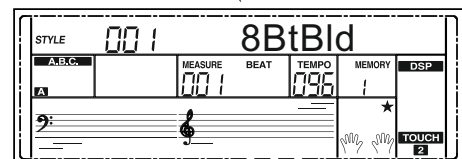
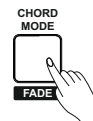
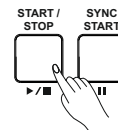
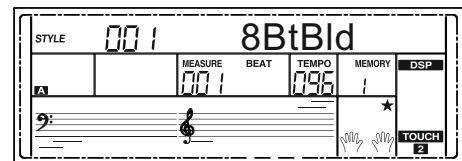
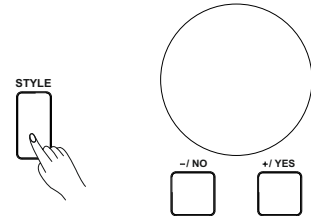

Accompaniment Sections

There are various types of Auto Accompaniment sections that allow you to vary the arrangement of the accompaniment to match the song you are playing. They are: Intro, Main (A, B), Fill (A, B), and Ending. By switching among them during your performance you can easily produce the dynamic elements of a professional sounding arrangement in your performance.

1. INTRO Section

The intro is an opening section of the song.

Each preset style features two different patterns. When the intro pattern finished, the system will automatically shift to the main section.

2. MAIN Section

The main is an important section of the song. And it plays an accompaniment pattern and repeat infinitely until another section's button is pressed.

3. FILL IN Section

Auto fill in function automatically adds a fill to your performance. When the fill-in is finished, accompaniment shifts to the Main section (A,B).

4. ENDING Section

Ending is used for the ending of the song. When the ending is finished, accompaniment automatically stops. The length of the ending differs depending on the selected style.

Note:

1. Holding down the [FILL A]/ [FILL B] button when the style is playing, the selected fill-in pattern repeats continuously until button is released.
2. Press [FILL A]/ [FILL B] button when style stops, it will change to the normal section.

Playing Different Accompaniment Sections

1. Press the [STYLE] button. Press the Style Direct Button, data dial or [+ / YES] / [- / NO] button to select a style.
2. Press [CHORD MODE] button to enter A.B.C. (auto bass chord) mode.
3. Press [SYNC START] button.
4. Press the [FILL A] button, select the Main A section.
5. Press the [INTRO/ENDING] button. Now the "A" indicate on LCD, and the style is ready to play.
6. It will start the accompaniment as soon as you start playing in Chord section. When the playback of the intro is finished, it automatically leads into Main A section.
7. Press the [FILL B] button. A fill-in plays, automatically followed by the Main B section.
8. Press the [INTRO/ENDING] button again, and it will enter the Ending Section. When the ending is finished, the auto accompaniment automatically stops.

Fade

1. Fade In

Starting the style with fade in produces a smooth beginning, the volume increases from low to high. Press and hold the [SHIFT] button and then press the [FADE] button when Style playback is stopped. The "▲FADE" icon will be lighting up, and then flashing with style playing.

2. Fade Out

Stopping the style with fade out produces a smooth ending, the volume increases from high to low. Press and hold the [SHIFT] button and then press the [FADE] button during Style playback. The "FADE ▾" icon will be lighting up, and then flashing with style playing.

3. Fade In/ Out Time

The default time value is 10 seconds.

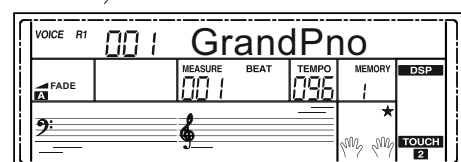
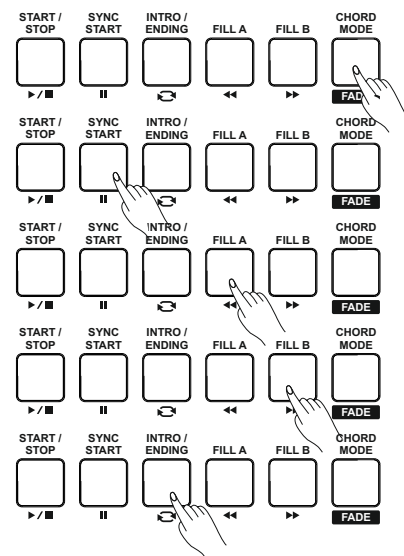
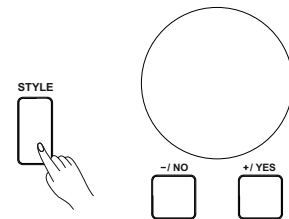
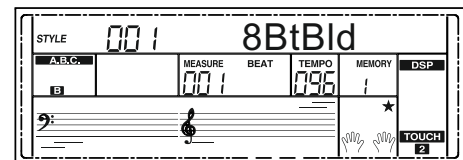
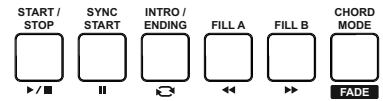

Auto Accompaniment

Accompaniment Volume Control

Adjust the master accompaniment volume; you can use this function to balance auto accompaniment part volume and keyboard voice volume.

1. Press and hold the [SHIFT] button, and then use the [ACCOMP +]/[ACCOMP -] button to set accompaniment volume, adjustable range: 0~127, the LCD displays current accompaniment volume value.
2. Press and hold the [SHIFT] button and then press the [ACCOMP +]/[ACCOMP -] for a while you can quickly adjust the volume value.
3. Press and hold the [SHIFT] button, at the accomp volume temporarily showed on the LCD, press the [ACCOMP +]/[ACCOMP -] button simultaneously to turn the accompaniment volume off. The LCD displays "OFF Accomp". Keep the [SHIFT] button pressed and then press the [ACCOMP +]/[ACCOMP -] button again to turn the accompaniment volume on.

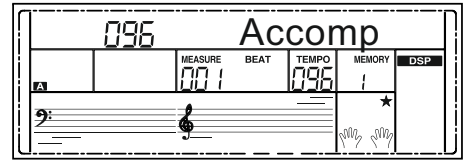

Chord Fingering

How the chords are played or indicated with your left hand (in the auto accompaniment section of the keyboard) is referred to as "fingering". There are 2 types of fingerings as described below.

Chord Basics

A chord, in music, is any harmonic set of three or more notes that is heard as if sounding simultaneously. The most frequently encountered chords are triads. A triad is a set of three notes that can be stacked in thirds. When stacked in thirds, the triad's members, from lowest pitched tone to highest, are called: the Root, the Third, and the Fifth.

Triad Type

There are following basic triad types:

| | |
|------------------|--|
| Major Triad | A root with a major third added above and a perfect fifth will consist as a "Major Triad". |
| Minor Triad | A root with a minor third added above and a perfect fifth will consist as a "Minor Triad". |
| Augmented Triad | A root with a major third added above and an augmented fifth will consist as an "Augmented Triad". |
| Diminished Triad | A root with a minor third added above and a diminished fifth will consist as a "Diminished Triad". |

Chord Inversion

We define this chord its root is not in the bass (i.e., is not the lowest note) as an inversion chord. When the root is in the bass, we call the chord: root-position chord. If we put the Third and Fifth in the root position, then it forms "Inversion", we call this chord "Inversion Chord". See the following major triad and its inverted chord.

Chord Name

The chord name contains two parts content: Chord root and Chord type.

Single Finger

Single finger type not only can detect single finger but also can detect multi finger. And the single finger makes it easily to play chords through only one, two or three keys. Including major, minor, seventh, and minor seventh chord. Refer to relevant picture on the right for details.

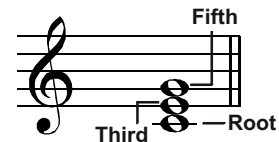

Major Triad Minor Triad



Augmented Triad Diminished Triad



Root Position First Inversion Second Inversion

Cm

Chord Root Chord Type

| | | |
|-----|--|---|
| C | | ★ Major Triad Only press the root note on the keyboard. |
| Cm | | ★ Minor Triad Press the root note and the nearest left black key simultaneously. |
| C7 | | ★ Seventh chord Press the root note and the nearest left white key simultaneously. |
| Cm7 | | ★ Minor seventh chord Press the root note and the nearest left white and black keys simultaneously. |

Multi Finger

Multi finger type only can recognize those chords have listed in the chord list, and also can be found in the dictionary function.

Note:

In full range mode, the entire keyboard will only recognize chords played in normal fingering.

| | | | | | |
|--|--|--|--|---|---|
| 0 C | 1 C ₆ | 2 C _{M7} | 3 C _{M7} (#11) | 4 C _M (9) | 5 C _{M7} (⁹) |
| 6 C ₆ (⁹) | 7 C _{aug} | 8 C _m | 9 C _m ₆ | 10 C _{m7} | 11 C _{m7} (^{b5}) |
| 12 C _m (⁹) | 13 C _{m7} (⁹) | 14 C _{m7} (¹¹) | 15 C _m _{M7} | 16 C _m _{M7} (⁹) | 17 C _{dim} |
| 18 C _{dim7} | 19 C ₇ | 20 C ₇ _{sus4} | 21 C ₇ (^{b5}) | 22 C ₇ (⁹) | 23 C ₇ (^{#11}) |
| 24 C ₇ (¹³) | 25 C ₇ (^{b9}) | 26 C ₇ (^{b13}) | 27 C ₇ (^{#9}) | 28 C _{M7} _{aug} | 29 C ₇ _{aug} |
| 30 C _{sus4} | 31 C ₁₊₂₊₅ | Notes enclosed in parentheses are optional; the chords could be recognized without them. | | | |

Tempo

Each style of the instrument has been set with a default or standard tempo; however, this can be changed by using the [TEMPO +]/[TEMPO -] button.

1. Use the [TEMPO +]/[TEMPO -] button to change the tempo. While the tempo data is flashing, use the data dial can also change the tempo.

2. Press the [TEMPO+] and [TEMPO-] buttons simultaneously to restore the default tempo setting.

Note:

The tempo will change when changing the style not playing the accompaniment. The tempo will not change when changing the style playing the accompaniment.

One Touch Setting

Sometimes it is difficult to pick up an appropriate voice to playing a song, but One Touch Setting Function can make it easy to get a perfect choice. When One Touch Setting is switched on, you can instantly recall all auto accompaniment related settings including voices selection and digital effects simply with a single touch of a button.

1. Press the [O.T.S.] button to turn on the One Touch Setting for current style. The LCD displays "O.T.S. ".

2. Press one of the One Touch Setting buttons [M1]-[M4]. Various panel settings (such as voice, effect, etc.) that match the selected style can be instantly recalled with just a single button press.

One Touch Setting parameter list:

Part ON/OFF (VOICER1, R2, L)
 Voice Change (VOICER1, R2, L)
 Voice Volume (VOICER1, R2, L)
 Voice Reverb Level (VOICER1, R2, L)
 Voice Chorus Level (VOICER1, R2, L)

Note:

1. The O.T.S. automatically turned off when you enter the song mode.
2. In O.T.S. mode, the memory cannot be registered.

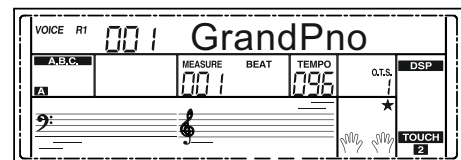
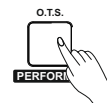
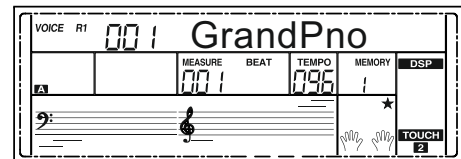
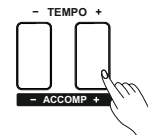

Harmony

The harmony function can add harmony effect to the main voice. If you turn the harmony on, the harmony function will automatically add harmony notes to the notes played in the right-hand section, which gives you a rich and harmonic expression.

Harmony Switch

1. Press [HARMONY] button. The LCD displays "OFF", which indicates the harmony effects turned off now.
2. When the LCD displays "OFF", repeat the previous operation. The LCD now displays "Hrm Duet", which indicates the harmony effect is open, and the type is Duet.
3. To choose a different harmony type, please refer to the harmony setting in function menu.

Play with harmony effect

Open the A.B.C., first play a chord, and then play notes in right hand section, the notes played in main voice will be added with the harmony effect.

Note:

The harmony types of 1+5, Octave 1~2, Echo 1~4, Tremolo 1~4 and Trill 1~4 will respond whether the A.B.C. is open or not. Other types of harmony will respond only when the A.B.C. is open.

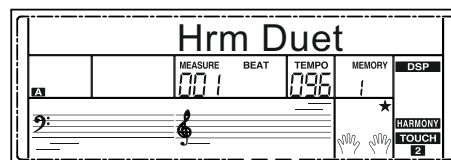
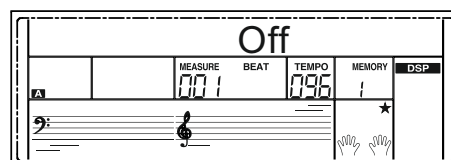

Performance Assistant

There are 2 voices you can select to perform in performance assistant mode: Guitar and Piano.

What's the performance assistant?

Performance assistant is an easy-to-use function. With this function you will find playing to be more interesting. Even if you are not a keyboard player, the performance assistant will help you to play your familiar instrument voice on the keyboard. If you're a pianist, you can easier to achieve many hard perform skills on the keyboard with the help of this function. Performance assistant will provided many wonderful phrases. Just use several keys and you will perform your own wonderful music.

Enter the Performance Assistant

1. Holding down [SHIFT] button, and then press [PERFORM] button you can enter the performance assistant mode. The default setting is Guitar Mode and the LCD will display Guitar's voice name.
2. You can use the Data Dial, [+ / YES] or [- / NO] button to change the voice you want to perform.
3. In the measure field in LCD, the "4-4" will be displayed. It means the default beat value is the 4/4 and you can change the beat value you want in function menu. Please refer to Performance Beat setting in function menu.
4. You can choose the beat between 2/4, 3/4, 4/4, and 6/8 beat.
5. In Performance Assistant mode, use [TEMPO+] or [TEMPO-] to change the tempo.

Guitar Mode

Guitar key map

The Guitar Mode makes you perform a guitar voice with keyboard just like you're playing a real guitar. In this mode you can use some perform skills like strum (5), broken chord (5), echoism (5) and also 2 endings.

Chord part

C2 to B3 is the chord part area. Play a chord in this area.

Sub Area 1

C4 to B4 (only white keys) is the sub area 1. 5 types of broken chord are provided in this area.

Sub Area 2

The 6 keys: C5 to A5 (only white keys) is just like real guitar's 6 strings. Play a free solo in this area.

Rhythm Area

C6 to G6 (only white keys) is the rhythm area. Wonderful styles and strums are provided in this area. Use A6 to B6 to play an ending.

Position Change

Press C7, the LCD highlight the performance assistant high cursor, repeatedly press the C7 key change the guitar voice between a high and a low position.

Note:

The keys above C7 don't respond in this mode.

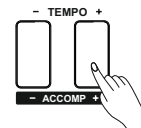
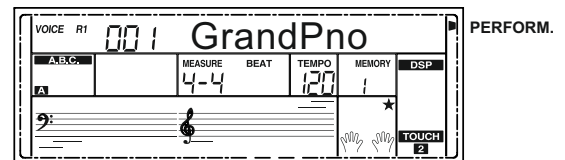
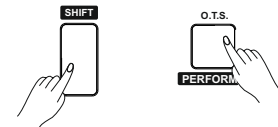

Guitar mode key map

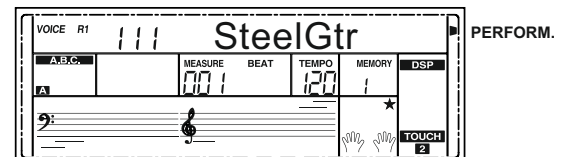
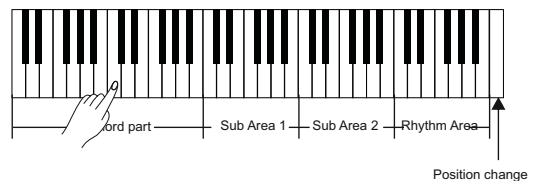

Playing in Guitar Mode

Play a chord in the chord part.

A chord type will be displayed on the LCD and the guitar root note will be sounded.

Play a broken chord in the sub area 1.

When the chord type displayed, press a white key in the sub area 1, a wonderful broken chord phrase will start. Try to change the white key and you will hear some different type of phrase. Change the chord with your left hand; you will hear the broken chord phrase has a little bit change.

Play a free solo in the sub area 2.

When the chord type displayed, press a white key in the sub area 2 you can play guitar free solo, sounds like you're playing a real one. Try to change the chord with your left hand, and play your free solo. The last white key B5 is invalid.

Play a strum rhythm in the rhythm area.

When the chord type displayed, press a white key in the rhythm area you can play the magic strum rhythm. Try to change the chord with your left hand, and play your strums.

End the guitar performing.

Press the A6 or B6 to end your guitar performs. When the ending is finished, the phrase stops automatically.

Play the echoism.

All of black keys on Sub area 1, Sub area 2 and Rhythm area are echoism keys. There are 5 kinds of echoism to arrange on the C#, D#, F#, G#, A# circularly.

Change the position

Press the C7, the PERFORM.H icon will be lightened on the LCD. It means that the guitar position has been changed to the High position. Try to play the white keys in sub area 1, Sub area 2 and Rhythm area, listen to the phrase you are performing now.

Guitar mode key map

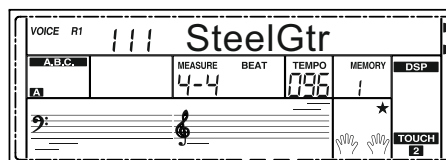
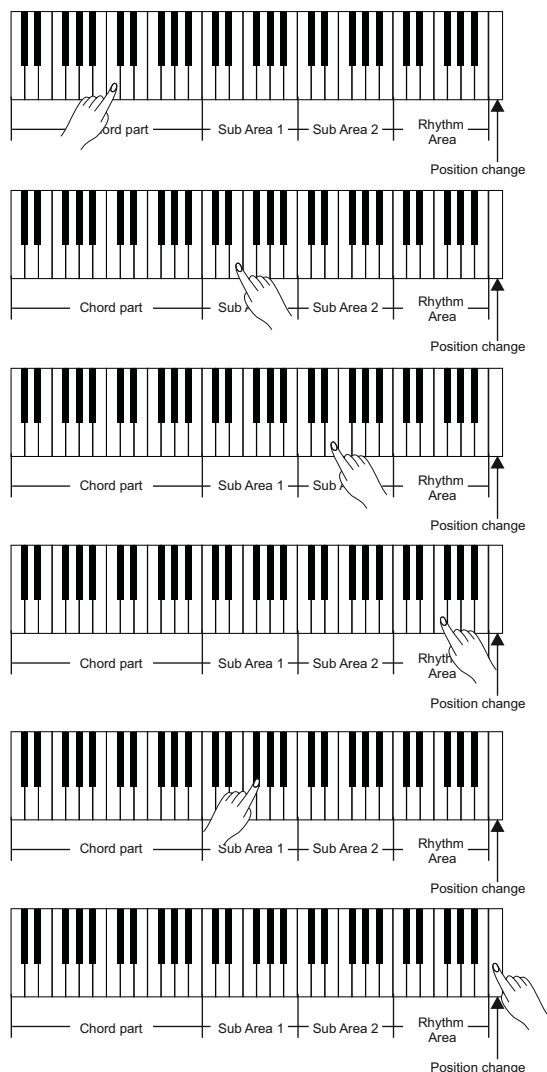

PERFORM.
PERFORM. H

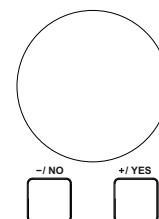

Piano Mode

Piano Key Map

In Piano Mode, you can easily to achieve many hard piano perform skills just like playing the acoustic one. In this mode you can use some perform skills like piano rhythm (5), broken chord (5) and also 3 endings.

The piano key map is similar with the guitar key map. Press A6 to C7 (white keys) will start an ending. All the black keys above C4 are invalid.

Playing in Piano Mode

1. Select Piano Mode.
In performance assistant mode, use data dial, [+ / YES] or [- / NO] button to select Piano Mode.
2. Play a chord in chord part. Play some phrases in Sub area and Rhythm area.
3. Press the A6, B6 or C7 to ending your piano perform. When the ending is finished, the phrase stops automatically.

Exit the Performance Assistant

When the phrase stops, press the [VOICE], [STYLE], [SONG], [DEMO], [SHIFT] + [PERFORM] to exit the Performance Assistant mode.

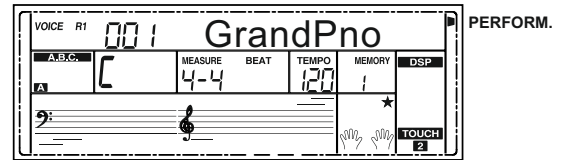
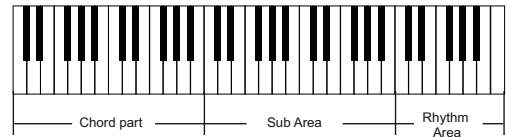

DSP

The DSP is a simulate sounds of sound localization technology in the real environment. Since each sound should be produced in a certain space, so when you at home, in cinema or in the wilderness, even play the same violin you can hear different sounds, the difference sounds are caused by different atmosphere. The DSP effect is set to ON and the icon on the LCD is lighten when keyboard is power on. Holding down [SHIFT] button and then press the [DSP] button to turn the DSP effect on or off. Refer to Function Menu for further editing effect type and depth.

Note:

It may cause a break or a noise while switching on/off the DSP when style and song playing. This is normal and need not panic.

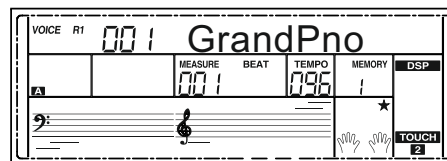

Mixer

Mixer function can control the volume of different tracks. It just likes a mini type mixing controller, separately control the left/right hand track volume, bass track volume, and rhythm track volume and so on.

1. Press the [MIXER] button to enter the mixer function menu, the LCD displays current rhythm volume value for the first time when powered on; after then it will keep your last options every time.
2. Repeatedly press the [MIXER] button to select one that you want to set.
Use [+ / YES] / [- / NO] button or data dial to change parameters.

The option and parameters are as follows:

| Content | LCD Display | Range |
|-------------------------------------|--------------|---------|
| Adjust the Percussion track volume. | XXX Rhythm_s | 0 - 127 |
| Adjust the Rhythm track volume. | XXX Rhythm_m | 0 - 127 |
| Adjust the Bass track volume. | XXX Bass | 0 - 127 |
| Adjust the Chord 1 track volume. | XXX Chord1 | 0 - 127 |
| Adjust the Chord 2 track volume. | XXX Chord2 | 0 - 127 |
| Adjust the Chord 3 track volume. | XXX Chord3 | 0 - 127 |
| Adjust the Phrase 1 track volume. | XXX Phrase1 | 0 - 127 |
| Adjust the Phrase 2 track volume. | XXX Phrase2 | 0 - 127 |
| Adjust the Upper 1 track volume. | XXX Upper 1 | 0 - 127 |
| Adjust the Upper 2 track volume. | XXX Upper 2 | 0 - 127 |
| Adjust the Lower track volume. | XXX Lower | 0 - 127 |

Note:

The function menu status will exit if no operation is done within 5 seconds.

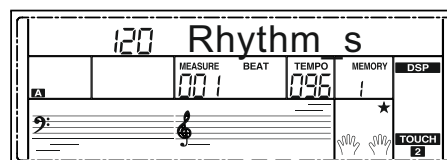
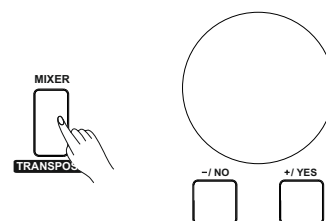

Pedal Function

Using pedal function can makes your performance more naturally and with greater expressiveness.

You can refer to Pedal Type chapter for details.

1. Sustain Pedal

This pedal function performs the same function as the damper pedal on an acoustic piano, letting you sustain the sound of voices even after releasing the keys.

Step and press on the pedal to turn the sustain effect on.

Release the pedal to turn the sustain effect on.

2. Soft Pedal

When the soft pedal is selected, pressing this pedal and makes them (the notes you play) sound softer.

3. Style Start/Stop Pedal

When the style start/stop pedal is selected, pressing this pedal to start/stop accompaniment.

4. Memory Pedal

When the memory pedal is selected, pressing this pedal at the first time to call up register memory: M1, and then you can call up register memory M2, M3...by pressing this pedal step by step (There are 48 memories).

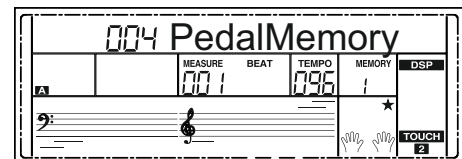
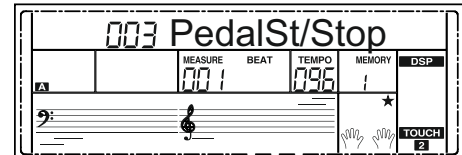
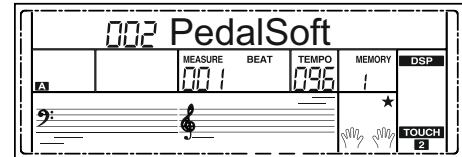
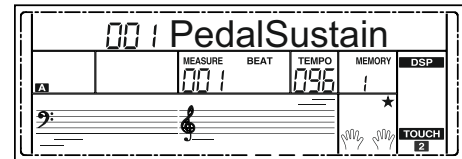

Function Menu

Press the [FUNCTION] button to enter function menu. The LCD displays the current function menu option. Use [+ /YES] / [- /NO] button or data dial to set parameter of the current menu.

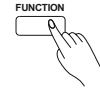

The option and parameters are as follows:

| NO. | Content | LCD display | Range | Default |
|-----|------------------|------------------|--|-----------|
| 1 | Tune | xxx Tune | -50 ~ +50 | 000 |
| 2 | Key Split | xxx KeySplit | 1~61 | 019 |
| 3 | Beat Type | xxx BeatType | 0, 2 ~ 9 | 004 |
| 4 | Metronome Volume | xxx MetroVol | 0~127 | 80 |
| 5 | Pedal Type | xxx Pedal xxxx | Sustain, Soft, St/Stop, Memory | Sustain |
| 6 | EQ Type | xxx EQ xxx | Pop, Rock, Class, Jazz, Dance, Reset | Reset |
| 7 | Reverb Type | xxx Rev xxxxx | Room1, Room2, Room3, Hall1, Hall2, Hall3, Church1, Church2, Delay, PanDelay | RevHall1 |
| 8 | Reverb Level | xxx ReverbVol | 0 ~ 127 | 70 |
| 9 | Chorus Type | xxx Chr xxxxx | Chorus1, Chorus2, GM Chorus1, GM Chorus2, Flanger1, Flanger2, Rotary1, Rotary2 | GMChorus2 |
| 10 | Chorus Level | xxx Hrm xxxxx | 0 ~ 127 | 0 |
| 11 | Harmony Types | | Duet, StandardTrio, Full Chord, Rock Duet, Country Duet, Country Trio, Block, 4 Close 1, 4 Close 2, 4 Open, 1+5, Octave1, Octave2, Strum, Echo1, Echo2, Echo3, Echo4, Tremolo1, Tremolo2, Tremolo3, Tremolo4, Trill1, Trill2, Trill3, Trill4 | HrmDuet |
| 12 | MIDI Receive | xxx Midi In | 1 ~ 16, ALL | ALL |
| 13 | MIDI Transmit | xxx Midi Out | 1 ~ 16 | 001 |
| 14 | Auto Power Off | xxx PowerOff | OFF, 30, 60 | 030 |
| 15 | Performance Beat | xxx Perform Beat | 4-4, 3-4, 2-4, 6-8 | 4-4 |

Note:

The function menu status will exit if no operation is done within 5 seconds.

Tune

This function sets the pitch of entire keyboard by steps of cents.

1. Repeatedly press the [FUNCTION] button to select the tune menu. The LCD displays "xxx Tune". Use [+ /YES] / [- /NO] button or data dial to change tune value. Its range is from -50 to 50 cents.

2. Press [+ /YES] and [- /NO] buttons simultaneously will set the tune value to its default setting: 000. The setting is applied to both accompaniment and the voice.

Key Split

The Point on the keyboard that separates voice L and voice R1/R2 is called the "split point". Left hand section controls the auto bass chord accompaniment when the A.B.C. function is on, or it can be used to play the lower voices when the A.B.C. function is off.

1. Repeatedly press the [FUNCTION] button to select split point menu. The LCD displays "xxx KeySplit" currently. Use [+ /YES] / [- /NO] button or data dial to change Split Point. The range of Split Point is: 1~61, press the [+ /YES] and [- /NO] buttons to restore its default setting.
2. Press [+ /YES] and [- /NO] buttons simultaneously will set the split point value to its default setting: F#3 (19).

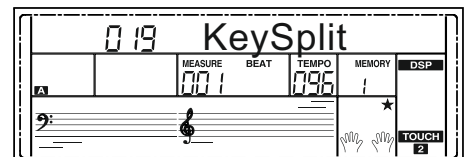
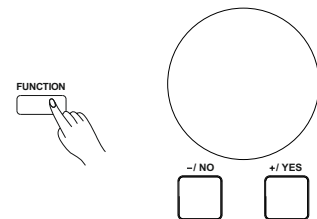
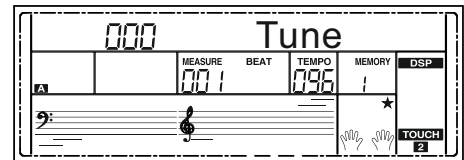
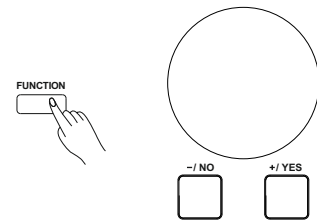

Beat Type

1. Repeatedly press the [FUNCTION] button to select beat type menu. The LCD displays “xxx BeatType”. Use [+ /YES] / [- /NO] button or data dial to change beat type. The range of beat type: 0, 2~9.
2. Press [+ /YES] and [- /NO] buttons simultaneously will set the beat type value to its default setting: 004.

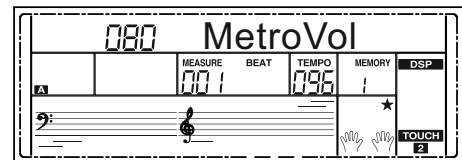
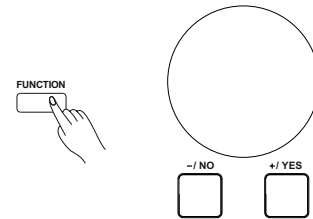
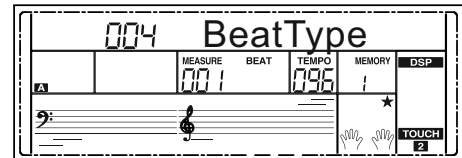
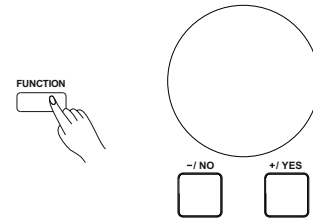

Metronome Volume

1. Repeatedly press the [FUNCTION] button to select metronome volume menu. The LCD displays “xxx MetroVol”. Use [+ /YES] / [- /NO] button or data dial to adjust metronome volume value. The range of metronome value is: 0 ~ 127.
2. Press [+ /YES] and [- /NO] buttons simultaneously will set the metronome volume value to its default setting: 080.

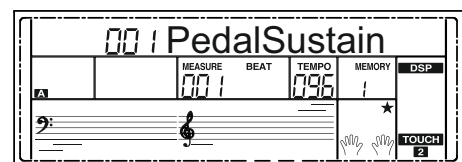
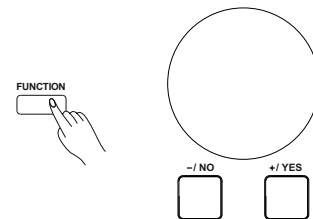

Pedal Type

1. Repeatedly press the [FUNCTION] button to select pedal type menu. The LCD displays “00x Pedal xxxx”. Use [+ /YES] / [- /NO] button or data dial to change pedal type. There are 4 types of pedal are available.
2. Press [+] and [-] buttons simultaneously will set the pedal type to its default setting: 001 PedalSustain. The pedal types are as follows:

| No. | LCD | Pedal Function |
|-----|--------------|---------------------|
| 1 | PedalSustain | Sustain Pedal |
| 2 | PedalSoft | Soft Pedal |
| 3 | PedalSt/Stop | Start/Stop Pedal |
| 4 | PedalMemory | Memory Switch Pedal |

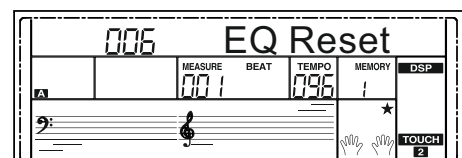
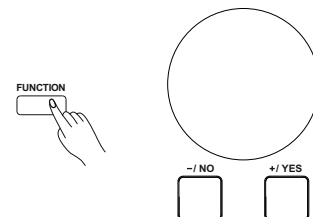

EQ Type

Equalizer is a sound processor that can be used to adjust gain value of each frequency band of sound, different gain value setting can make a different sound field effect. You can select one of the 6 preset EQ settings in the EQ display.

1. Repeatedly press the [FUNCTION] button to select the EQ type menu. The LCD displays “006 EQ Reset”. Use [+ /YES] / [- /NO] button or data dial to change EQ type.
2. Press [+] and [-] buttons simultaneously will set the EQ type to its default setting: 006 EQ Reset.

Function Menu

The EQ types are as follows:

| No. | LCD | EQ Type |
|-----|----------|-----------|
| 1 | EQ Pop | Pop |
| 2 | EQ Rock | Rock |
| 3 | EQ Class | Classical |
| 4 | EQ Jazz | Jazz |
| 5 | EQ Dance | Dance |
| 6 | EQ Reset | Reset |

Reverb Type

1. Repeatedly press the [FUNCTION] button to select reverb type menu. The LCD displays "004 Rev Hall1". Use [+ /YES] / [- /NO] button or data dial to change reverb type.
2. Press [+] and [-] buttons simultaneously will set the reverb type to its default setting: 004 Rev Hall1.

The reverb types are as follows:

| No. | LCD | Reverb Type |
|-----|--------------|-------------|
| 1 | Rev Room1 | Room 1 |
| 2 | Rev Room2 | Room 2 |
| 3 | Rev Room3 | Room 3 |
| 4 | Rev Hall1 | Hall 1 |
| 5 | Rev Hall2 | Hall 2 |
| 6 | Rev Hall3 | Hall 3 |
| 7 | Rev Church1 | Church 1 |
| 8 | Rev Church2 | Church 2 |
| 9 | Rev Delay | Delay |
| 10 | Rev PanDelay | Pan Delay |

Reverb Level

1. Repeatedly press the [FUNCTION] button to select reverb level. The LCD displays "xxx Reverb Vol". Use the [+ /YES] / [- /NO] button or data dial to change reverb level, adjustable range is: 0-127
2. Press the [+ /YES] and [- /NO] buttons simultaneously to restore its default setting: 070

Chorus Type

1. Repeatedly press the [FUNCTION] button to select chorus type menu. The LCD displays "004 GM Chorus2". Use [+ /YES] / [- /NO] button or data dial to change chorus type.
2. Press the [+ /YES] and [- /NO] buttons simultaneously to restore its default setting: 004 GM Chorus2.

The chorus types are as follows:

| No. | LCD | Chorus Type |
|-----|--------------|-------------|
| 1 | Chr Chorus1 | Chorus 1 |
| 2 | Chr Chorus2 | Chorus 2 |
| 3 | GM Chorus1 | GM Chorus 1 |
| 4 | GM Chorus2 | GM Chorus 2 |
| 5 | Chr Flanger1 | Flanger 1 |
| 6 | Chr Flanger2 | Flanger 2 |
| 7 | Chr Rotary1 | Rotary 1 |
| 8 | Chr Rotary2 | Rotary 2 |

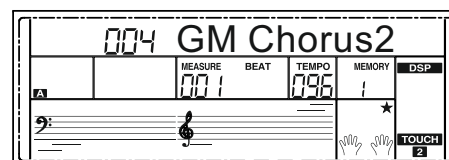
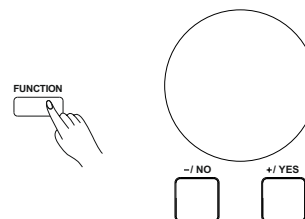
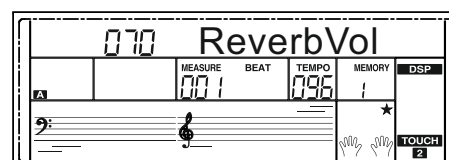
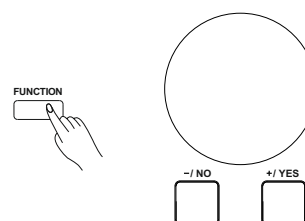
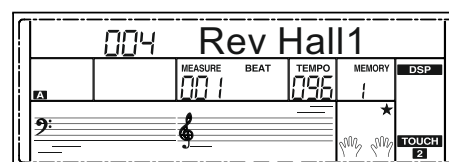
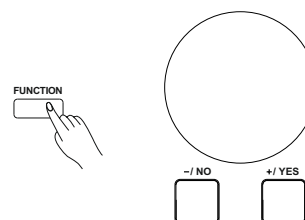

Chorus Level

1. Repeatedly press the [FUNCTION] button to select chorus level menu. The LCD displays "xxx ChorusVol". Use the [+ /YES] / [- /NO] button or data dial to change chorus level, adjustable range: 0-127.
2. Press the [+ /YES] and [- /NO] buttons simultaneously to restore its default setting: 000

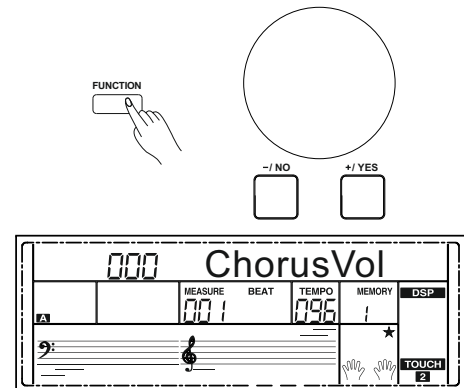

Harmony Type

1. Repeatedly press the [FUNCTION] button to select harmony type menu. The LCD displays "001 Hrm Duet". Use [+ /YES] / [- /NO] button or data dial to change harmony type.
2. Press the [+ /YES] and [- /NO] buttons simultaneously to restore its default setting: 001 Hrm Duet.

The harmony types are as follows:

| No. | LCD | Harmony Type |
|-----|--------------|--------------|
| 1 | Hrm Duet | Duet |
| 2 | Hrm StdTrio | StandardTrio |
| 3 | Hrm FulChord | Full Chord |
| 4 | Hrm RockDuet | Rock Duet |
| 5 | Hrm CtryDuet | Country Duet |
| 6 | Hrm CtryTrio | Country Trio |
| 7 | Hrm Block | Block |
| 8 | Hrm 4Close1 | 4 Close 1 |
| 9 | Hrm 4Close2 | 4 Close 2 |
| 10 | Hrm 4Open | 4 Open |
| 11 | Hrm 1+5 | 1+5 |
| 12 | Hrm Octave1 | Octave 1 |
| 13 | Hrm Octave2 | Octave 2 |
| 14 | Hrm Strum | Arpeggio |
| 15 | Hrm Echo1 | Echo1 |
| 16 | Hrm Echo2 | Echo2 |
| 17 | Hrm Echo3 | Echo3 |
| 18 | Hrm Echo4 | Echo4 |
| 19 | Hrm Tremolo1 | Tremolo1 |
| 20 | Hrm Tremolo2 | Tremolo2 |
| 21 | Hrm Tremolo3 | Tremolo3 |
| 22 | Hrm Tremolo4 | Tremolo4 |
| 23 | Hrm Trill1 | Trill1 |
| 24 | Hrm Trill2 | Trill2 |
| 25 | Hrm Trill3 | Trill3 |
| 26 | Hrm Trill4 | Trill4 |

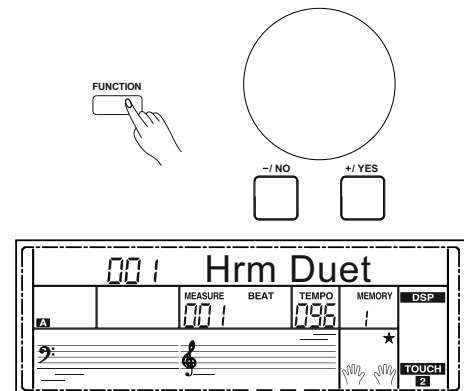

Function Menu

MIDI IN

1. Repeatedly press the [FUNCTION] button to select MIDI in menu. The LCD displays “xxx Midi In”. Use [+ /YES] / [- /NO] button or data dial to change MIDI in channel: 1~16, ALL.
2. Press [+ /YES] and [- /NO] buttons simultaneously to restore MIDI in channel to its default setting: ALL.

MIDI OUT

1. Repeatedly press the [FUNCTION] button to select MIDI out menu. The LCD displays “xxx Midi Out”. Use [+ /YES] / [- /NO] button or data dial to change MIDI out channel: 1~16.
2. Press [+ /YES] and [- /NO] buttons simultaneously to restore MIDI out channel to its default setting: 001.

Auto Power Off

This function is used to set the auto power off time.

1. Repeatedly press the [FUNCTION] button to select auto power off menu. The LCD displays “xxx Power Off”. Use [+ /YES] / [- /NO] button or data dial to change auto power off time: 30 minutes, 60 minutes or OFF.
2. Press [+ /YES] and [- /NO] buttons simultaneously will set the default setting is: 030 (30 minutes).

Performance Beat

This function is used to set the performance assistant beat type.

1. Repeatedly press [FUNCTION] button to select Perform Beat menu. The LCD displays “xxx Perform Beat”. Use [+ /YES] / [- /NO] or data dial to change performance beat: 4-4, 3-4, 2-4, 6-8.
2. Press [+ /YES] and [- /NO] buttons simultaneously will set performance beat channel to its default setting: 4-4.

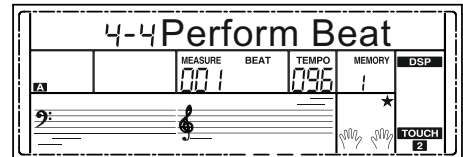
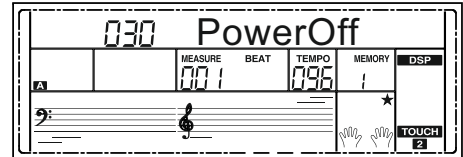
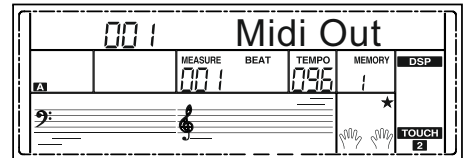
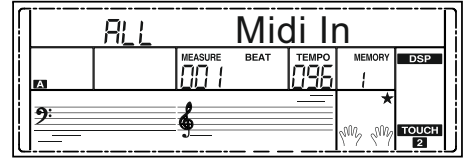
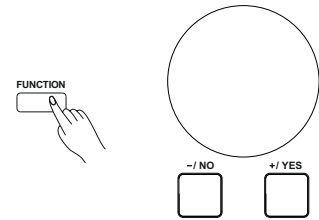

Restore Factory Setting

Pressing and holding [+ /YES] and [- /NO] button together and then turn the power on, the instrument would be restored to factory setting. It will delete all the user data: user styles, user songs and registered memory. The LCD will display “Loading!”. After the restore completed, the instrument will start normally.

Register Memory

The Registration Memory feature can make your performance more easily and efficiently. It allows you to save virtually all panel settings to a Registration Memory setting, and you can instantly recall custom panel settings by pressing a single button.

Registering the Panel Setting

1. There are 8 memory banks, and each bank has 6 memories (M1-M6).
2. Holding down the [STORE] button press one of the registration memory buttons: [M1] - [M6]. Notice that the new settings will replace the previous memory data.

Note:

Press [STORE] and [M1] button then power on, the registration memory will be set to default.

Recalling the Registered Panel Settings

Press one of the registration memory buttons: [M1] - [M6]. In this example, the panel settings stored in the memory 2 of bank 1 are recalled.

Note:

Registration data cannot be recalled when the One Touch Setting function is on.

Selecting a Registration Bank

1. Press the [BANK] button. The LCD will display the number of memory.
2. There are 8 banks in all and each bank has 6 memories (M1-M6). Repeatedly press the [BANK] button to select bank settings.
3. You can save following parameters into M1-M6 registered memory:
 - Voice Parameter:** including voice, dual, lower, DSP, mixer.
 - Accompaniment Parameter:** including style, tempo, and accompaniment no/off.
 - Function Parameter:** including velocity, part parameters in function menu.

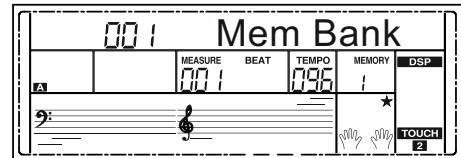
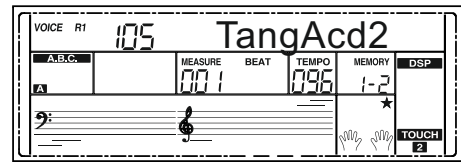
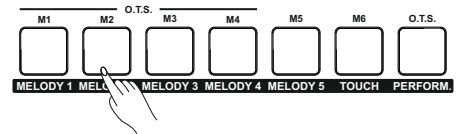
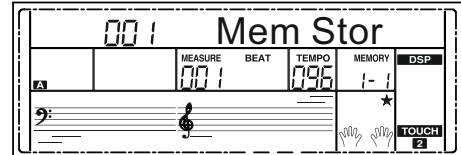
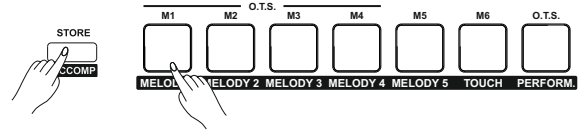

Song Album

The instrument has Song Album function. It presets 310 album songs parameter, which includes style type, tempo, and voice. You can play the preset song using song album function using the parameter in accordance with that song. Please refer to appendix for album list.

1. Holding down [SHIFT] button and then press the [ALBUM] button can turn the album function on or off.
2. When the album function is on, LCD displays the name of album song and the indicate of album. Now use the data dial, [+ / YES] or [- / NO] button can select the song to play. The instrument will adjust the accompaniment parameters to fit that song.
3. Press voice direct button or style direct button can exit the album function.

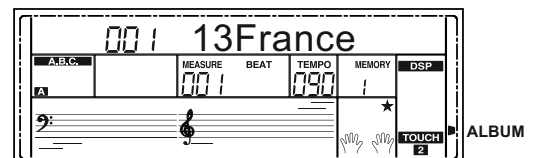
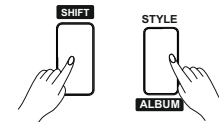

Record

With the easy-to-use song recording features, you can record your own keyboard performances as a user song. 5 user songs can be recorded with 6 tracks (1 ACCOMP track, 5 MELODY tracks) each.

Start Recording

Before you start recording, you need to select a user song to keep the recording song.

1. Holding down [SHIFT] button and then press the [RECORD] button to enter user song selection mode. The LCD displays "RecSong1" and sequence number. 5 user songs can be recorded. Use the data dial, [+ / YES] or [- / NO] button select the user song you want to record.
2. Holding down [SHIFT] button and then press the [RECORD] button again to enter record preparation mode. LCD lightens the "REC" flag, and LCD will flash beat indicate. The instrument will automatically select an empty track to record your performance. The LCD indicates in the left which flashes shows the record track.
3. In the recording preparation status, you can adjust parameters such as the voice, style and tempo. When recording a new song, it will automatically select "Melody 1" as the recorded track. Holding down [SHIFT] button and then press "ACCOMP" (or "MELODY1" to "MELODY 5") to make your own selection. The ACCOMP track and one of MELODY track can be recorded at the same time, but it cannot record two MOLODY track simultaneously.
4. Press [START/STOP] button or play the keyboard to start recording. When choosing the ACCOMP tack and A.B.C. is open, play an effective chord in left hand section or press [START/STOP] button would start recording.

Select a Track

The recording track LCD indicates has three states: Blinking, Light, and Go out.

Blinking: It means the track was chosen for recording. If the track has recorded data, the original data will be replaced.

Light: It means this track have data, the recording process will record data with playback the recorded track at the same time.

Go out: There are two cases, one is that this track has data and cannot playback when recording, the other one is that this track has no data and you can select "ACCOMP" track (or "MELODY 1" or "MELODY 2"), repeatedly press buttons which corresponding to each track, shift track state between blinking, light and go out.

Note:

1. Record style with accompaniment track, and record melody with melody track.
2. In the recording preparation status, you can repeatedly press the [ACCOMP], [MELODY 1] ~ [MELODY 5] button to shift track state. When recording an existing song, the keyboard will automatically select the empty track next to the occupied track. For example, if "Melody 1" is occupied, then "Melody 2" will be selected as the record track. When all 6 tracks have been recorded, select the "melody 1" track to save recordings.

Stop Recording

1. When recording is in process, holding down [SHIFT] button and then press the [RECORD] button to stop recording.

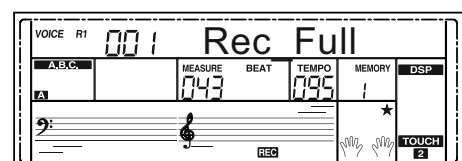
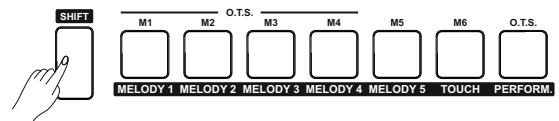
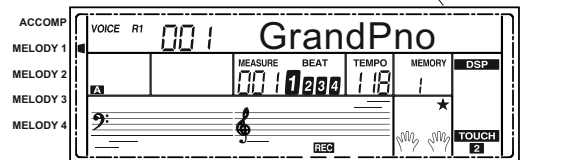
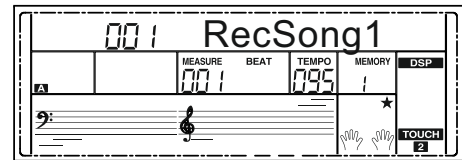

- When recording is in process, if the memory is full, the recording will stop and save automatically, and the LCD displays "Rec_Full".
- If you choose the accomp recording, the recording will stop automatically when the ending of the rhythm finishes.

Playback Recording

- When recording is in process, holding down [SHIFT] button and then press the [RECORD] button, it will stop recording and enter the song play mode, the LCD displays default name "UserSong" and number of user song, the current recorded song will play automatically in circle.
- Press the [SONG] button to enter the song mode and it will play all songs circularly. Use the data dial, [+ /YES] or [- /NO] button to select a song, there are 155 songs in all, including 5 user songs (151~155). If there is no data in the selected user song, it will display "NoFile!" and stop playing.
- You can select one user song in song stop playing mode, press [START/STOP] button, this user song will play circularly.

Note:

- All user songs won't be erased even turn the instrument off.
- In user song selection mode, just easily press the corresponding track button to choke track, the prompt icon goes out at the same time and the tracks you have selected will not be sounded while playing back it.

Delete User Song

- Pressing and holding [RECORD] and [STORE] button together and turn power on simultaneously, all user songs will be erased.
- In the recording preparation status, holding down [SHIFT] button and then press the [RECORD] button for two seconds, the LCD will display "Delete?" Now you can press [ACCOMP] (or [MELODY 1] to [MELODY 5]) button to select the track you want to delete. When some track indicate is lightened, it indicates that the track data you want to delete, otherwise, it indicate that the track data you want to keep. If all the track indicates are lightened, the whole user song will be erased after confirmation.
- Choose the track you want to delete, press [+ /YES] to confirm and the recorded data in this track will be erased. Press [- /NO] to quit this step, and go back to the recording preparation status.

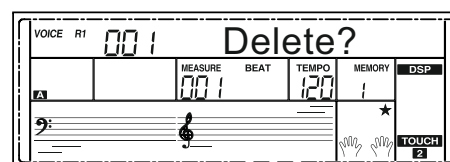
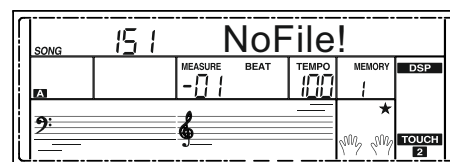

Song

The instrument has 150 songs in all, and each song has equipped with smart learning mode.

Listen to the songs

1. Press the [SONG] button to enter the song mode. The LCD shows "SONG" indicate and it will play all songs circularly.
2. Use the data dial, [+ / YES] or [- / NO] button to select a song.
3. Once you start playing a song by pressing [▶/■] button, it will play current song repeatedly.
4. When the song is stopped, press the [STYLE], [RECORD], [VOICE], [DUAL] OR [LOWER] button and so on will exit the song mode.

Song Control

1. **Introductory Beat**
Before song start playing, it has the introductory beat; the measure starts from negative value. It begins to play song when the measure goes to 1.
2. **REW, FF and PAUSE**
When the song is playing:
Press the [▶▶] button to fast forward the song.
Press the [◀◀] button to rewind the song (base on the measure).
Press the [⏸] button to pause the playing song, press again to continue playing.
3. **Song Repeat**
When playing the song, press the [↺] to set the loop begin and press it again to set the loop end. When in loop status, press [↺] again to quit the loop playing status.

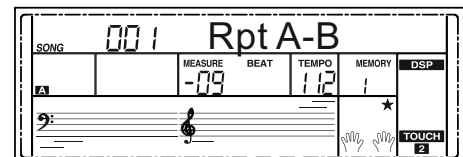
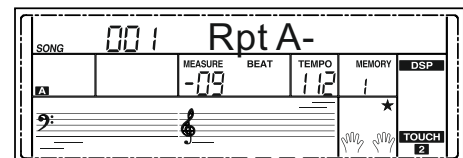
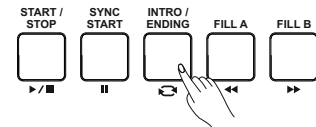
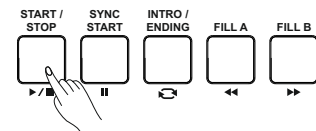
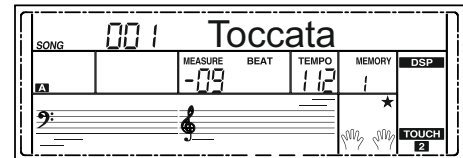

Smart Learning System

This built-in smart learning mode provides many different ways in which to help you learning a new song faster and better. It's function mainly includes: Intelligently and reasonably arrange your learning lessons; Arrange songs specific exercises for your study; Record your learning progress; the more your learning level have progressed, the more starts you will get.

Smart Learning

How to start the smart learning mode?

Press the [SMART LEARNING] button, the information of name and number of song you want to learn will scrolling on the LCD screen, and then Temporarily display the lesson you are going to learn, then enter the song learning mode.

Note:

- As scrolling the name of song, the LCD displays difficult level of song learning in the Grade Level area, as the picture of LCD on the right, the current grade level is a sun, one sun equals to three starts, and that is to say it is a very hard difficulty level. You can refer to level details on the right.
- Use the data dial, [+ / YES] or [- / NO] button conveniently select a song from easy to difficult levels.
- In the process of learning, the LCD displays the highest score of previous challenge learning. The default score is 0.

What is period and phrase?

The fastest way to learning a new song is divide the song into several parts, and individually practice each part. While you have a good command of each part, it may become very easy to learning a complete song.

A musical phrase is a unit of musical meter that has a complete musical sense of its own. Just like a complete sentence in an article. In music, a period is a group of phrases consisting usually of at least one phrase, a common combination is two or four phrases, but three, five or more phrases still exist.

Refer to the relationship of song, period and phrase on the right picture.

How to practicing with smart learning?

In order to help you learning songs faster and easier, 8 lessons have pre-programmed in this instrument, step learning of pitch, timing, left hand, right hand, period, phrase and so on, try to learning a new song in an enjoyable way. The contents of each lesson are referring to the following list:

| NO. | LCD | Content of Lesson |
|-----|----------|---|
| 1 | LESSON 1 | Learn right hand pitch of period/phrase. |
| 2 | LESSON 2 | Learn right hand pitch and timing of period/phrase. |
| 3 | LESSON 3 | Learn left hand pitch of period/phrase. |
| 4 | LESSON 4 | Learn left hand pitch and timing of period/phrase. |
| 5 | LESSON 5 | Learn both hands pitch of period/phrase. |
| 6 | LESSON 6 | Learn both hands pitch and timing of period/phrase. |
| 7 | LESSON 7 | Learn both hands pitch and timing of complete song. |
| 8 | LESSON 8 | High score challenge. |

The system auto start lesson 7 (complete song learning) after you have finished lessons from 1 to 6.

During the learning of lesson 7, the system will automatically call up the period which you have played with most mistakes, individually practice this period, until you can expertly play this song.

After finished above lessons, the system will automatically turn into the lesson 8 (High score challenge), you can challenge the highest score, and the score will be permanently recorded.

As picture shows on the right, you can find the typical process of intelligent learning.

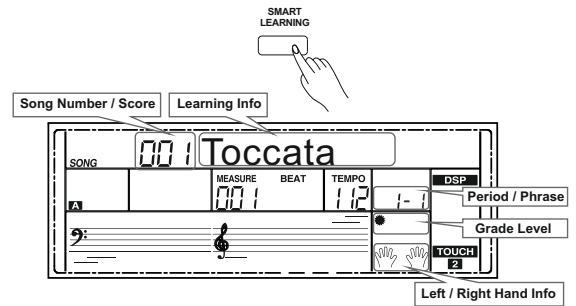

| LCD Display | Grade Level |
|-------------|-------------|
| ☀️ ☾ ☾ ☆ ☆ | Very Easy |
| ☀️ ☾ ☾ ☆ ☆ | Easy |
| ☀️ ☾ ☾ ☆ ☆ | Medium |
| ☀️ ☾ ☾ ☆ ☆ | Hard |
| ☀️ ☾ ☾ ☆ ☆ | Very Hard |

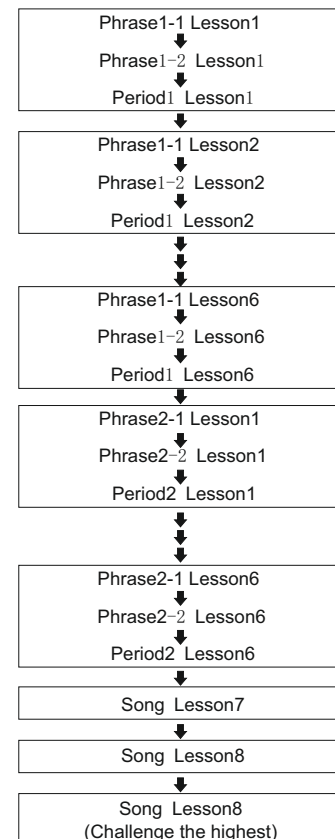
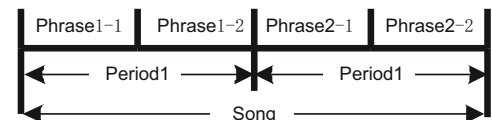

Smart Learning System

Prompt Message

| LCD | Description |
|------------|--|
| Lesson 1 | Prepare for the next lesson. |
| Play A | preview the phrase which you ready to learn |
| Try A | Prompt the phrase which you are learning. |
| Go Ahead | You have passed the current period/ phrase, please prepare for the next period / phrase. |
| Try Again | You haven't passed the current period/ phrase, please try again. |
| Play A-H | preview the period you ready to learning |
| Try A-H | Prompt the period you are learning. |
| Complete ! | You are going to lesson 7 (Complete song learning). |
| Challenge! | You are going to lesson 8 (High score learning). |
| Score: 85 | Your learning score. |
| Retry ? | Prompt if you want to play again when you finish this challenge learning. |

Lesson 1/3/5 (Pitch)

With lesson 1/3/5, you can learn how to currently play melody pitch and accompaniment chords of songs. These three lessons are played in a same method. We are going to introduce the lesson 1 as an example.

1. Press [SMART LEARNING] button, start the smart learning. Use data dial or [+ / YES] / [- / NO] button to select a song you want to learn.
2. The LCD currently displays name and number of song and, a litter while, display the name of lesson "Lesson 1". Now, it begins to play phrase, the LCD display "Play A", at the same time, listening carefully and watching each note of staff.
3. While introduce phrase stop playing, lesson 1 will be started. The LCD displays "Try A", and you can play the right key according to the staff.

Note:
Unless you press the right note on the keyboard, the song will continue playing normally. If you don't play the keys, the lesson mode will keeps waiting until you play a correct note.
4. After you have finished this phrase the LCD will display your current learning score "SCORE: XX". If you have got a score of 80 or more points, congratulations, you have passed this lesson, and you can enter the next phrase learning. The LCD displays "Go Ahead". If you have got a score less than 80 points, the LCD displays "Try Again", it means you have to repeat this phrase again.

Note:

If you still cannot get 80 points after repeat this phrase 3 times, the system will replay the current phrase again to help you be familiar with it. Repeatedly practice, until you play these phrases.

Lesson 2/4/6 (Pitch and Timing)

With lesson 1/3/5, you can learn how to currently play melody pitch and accompaniment chords of songs, and then practice with lesson 2/4/6 you can further control the timing better. That is to say, play songs with correct timing, pitch or chord.

These three lessons are played in a same method. We are going to introduce lesson 2 as an example.

1. The system automatically enters the lesson 2 after you have passed the lesson 1; The LCD displays "Lesson 2".
2. In lesson 2 mode, the system will preview the period /phrase you want to play, and then restart the lesson 2 learning. The LCD displays "Try A".

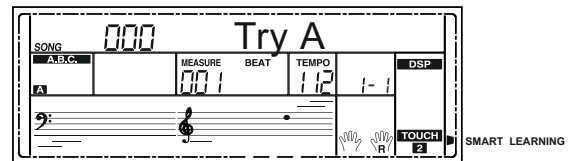
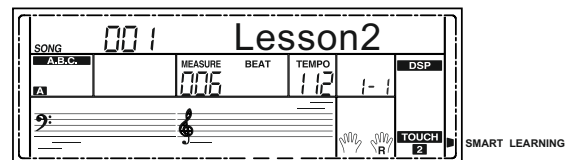
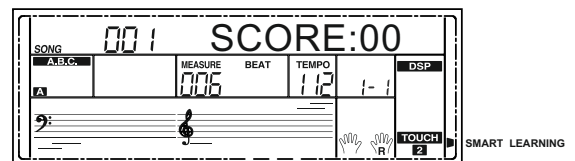
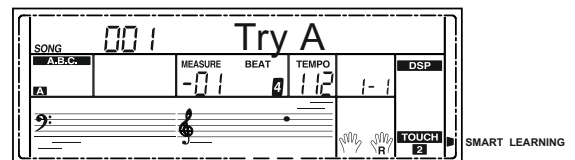
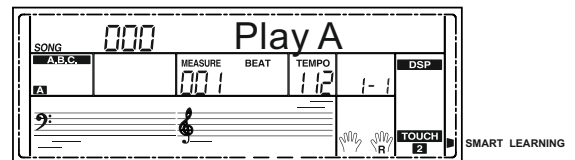
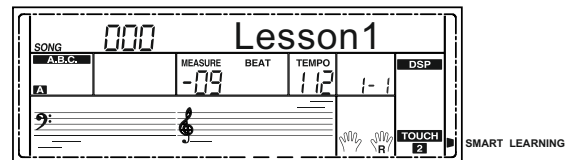
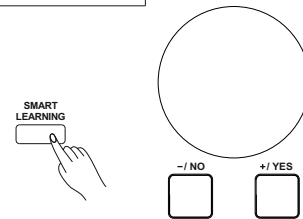

- The LCD currently displays your learning score: "SCORE: XX". If your score is or more than 80 points, you can prepare for the next lesson, the LCD will display "Go Ahead", or the LCD will display "Try Again", repeat practicing current phrase.
- The tempo will decrease about 10%, if the period/phrase still cannot pass after 3 times practicing (For example, the original tempo is 100, and will down to 90); you can practice with the new tempo.
If your score reach 80 points, the tempo will automatically recover 10%, repeatedly practice period/phrase until you can play songs smoothly at the original tempo.

Note:

The tempo value will decrease about 50% at most. In addition, you can press [TEMPO +] and [TEMPO -] buttons simultaneously to reset its original default value.

Lesson 7 (Complete Song Learning)

- Normally, you can start lesson 7 after finished lesson 1~6. Of course, you can directly enter lesson 7 by pressing [▶▶] button. The LCD displays "Complete!" means you are preparing to learn lesson 7.
- In lesson 7 mode, the instrument will completely play back a song for once, and then start pitch and timing practicing. After that, the system will pick up phrases which played with most mistakes. Focus on these phrases learning.
After phrases learning, the system restarts complete song learning. Repeatedly practice until you can play the song smoothly.

Lesson 8 (High Score Challenge)

Finish above lessons, you can automatically enter the lesson 8 learning, the high score learning. The LCD displays "Challenge!" and your score of last challenge.
Surely, if you want to directly challenge a song, you can press [▶▶] button, and switch to lesson 8 quickly. After you finish this lesson, the LCD will display your score and corresponding prompt sound. As the list below:

| Score | Prompt Sound |
|--------|--------------|
| <60 | Try Again |
| 60~69 | Ok |
| 70~79 | Good |
| 80~89 | Very Good |
| 90~100 | Excellent |

If the final score is more than the highest score of this song records, then congratulations! This indicates that you have challenged successfully and your study score will be permanently recorded.

Select a Lesson

Except follow the principle learning procedure, you can also press the [◀◀] or [▶▶] button to freely select a lesson.

You can select a lesson from lesson 1 to lesson 8; the LCD will display relevant information of lesson.

Pause the Lesson

Press the [⏸] button during lesson learning. Press the [⏸] button again and the lesson will resume from the current position.

Note:

The [⏸] button cannot be used to pause lesson learning in lesson 1/3/5.

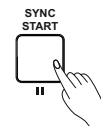
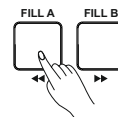
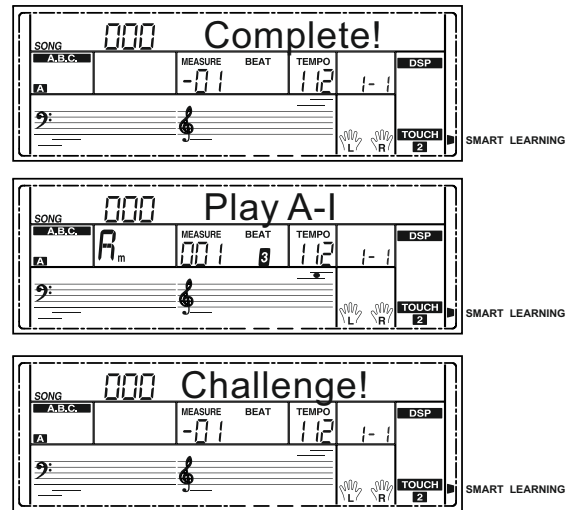

Stop/Start the Lesson

In the process of learning you can press the [start/stop] button to stop or start to learn, if in the process of learning to press the [start/stop] button will stop and return to you for what you have learn the current courses.



The Records of Lesson Learning Process

Your lesson learning process will be recorded even turn the power off; in other words, the system will automatically skip into the last position you exit, when you enter the smart learning next time.

Note:

The recorded learning position will be lost if you turn the power to the instrument off without executing the save operation. For example, un-normal power off and suddenly electronic cut off.

Metronome Introductory Learning

The introductory metronome provides a click sound, giving you an accurate tempo guide when you practice, or letting you easily start the lesson learning.

Note:

Cause only two tracks in a piano song, in lesson 6/7/8, there is no any accompaniment music, so, in the mean time, the system will automatically start metronome to help your lesson learning.

Gold Star

This instrument has equipped the gold star list, which can be used to mark your learning steps from a rookie level to a master level. It just likes your loyal music partner; record every progress you have made. As the time you have practiced and high score challenge you have passed, you can get more gold stars.

The LCD will display the star level when you power on, it indicates your instrument level. There are 17 levels in all, please refer to the list below:

| Rank | Display | Rank | Display |
|------|----------|------|----------|
| 1 | ☀️ ☾☾ ☆★ | 10 | ☀️ ☾☾ ☆★ |
| 2 | ☀️ ☾☾ ★★ | 11 | ☀️ ☾☾ ★★ |
| 3 | ☀️ ☾☾ ☆☆ | 12 | ☀️ ☾☾ ☆☆ |
| 4 | ☀️ ☾☾ ☆★ | 13 | ☀️ ☾☾ ☆★ |
| 5 | ☀️ ☾☾ ★★ | 14 | ☀️ ☾☾ ★★ |
| 6 | ☀️ ☾☾ ☆☆ | 15 | ☀️ ☾☾ ☆☆ |
| 7 | ☀️ ☾☾ ☆★ | 16 | ☀️ ☾☾ ☆★ |
| 8 | ☀️ ☾☾ ★★ | 17 | ☀️ ☾☾ ★★ |
| 9 | ☀️ ☾☾ ★★ | | ☀️ ☾☾ ★★ |
| | ☀️ ☾☾ ☆☆ | | |

Note:

1. The ☾ equals three ★, and the ☀️ equals nine ★.
2. The level of gold star list depends on the score of song learning and the time you have practiced.

If you know the name of a chord but don't know how to play it, you can use the Chord Dictionary function. You can learn the chord and test in this features.

DICT 1 (Chord Learning Mode)

Press and hold the [SHIFT] button, and then press the [DICT.] button to enter the DICT 1 mode, the LCD displays "Dict.1" and the A.B.C. automatically turned on. In DICT 1 mode, the keys C4~B5 are used to assign the Chord Type, the keys C6~B6 are used to assign the Chord Root. When the Chord Type and Chord Root are confirmed, the LCD will display the Chord and its keyboard position. For example, if you want to play a CM7 Chord, press the C6 key to specify C as the chord root. The root note you set will be shown on the LCD but the note doesn't sound. Refer to the picture on the right for assigning the Chord Root.

Press the E4 key to specify M7 as chord type. The notes you should play for the specified chord (root and chord type) are shown in the LCD as the notation and also in the keyboard diagram. When the Chord Type and Chord Root are confirmed, the LCD will display the chord and its keyboard position. A prompt sound will be heard when you play it correctly.

DICT 2 (Chord Examining Mode)

Press and hold the [SHIFT] button, and then press the [DICT.] button to enter the DICT 2 mode. This is an Examining mode. The chord area on the LCD will display a random chord while the keyboard position doesn't display anything on LCD. When you play the correct chord within 3 seconds, the next chord (random) will be displayed on LCD to wait for the correct chord playing. If not, LCD will display the corresponding keyboard position automatically. In DICT 2 mode, press and hold the [SHIFT] button, and then press the [DICT.] button again to turn off chord dictionary.

24 Chords will be displayed in the dictionary mode as follows:

| Note | Chord Root | Note | Chord Root | Note | Chord Root |
|------|------------|------|------------|------|------------|
| C6 | C | C4 | M | C5 | 7(b9) |
| C#6 | C#/Db | C#4 | M(9) | C#5 | 7(9) |
| D6 | D | D4 | 6 | D5 | 7(#9) |
| Eb6 | Eb/D# | Eb4 | mM7 | Eb5 | 7(b13) |
| E6 | E | E4 | M7 | E5 | 7(13) |
| F6 | F | F4 | M | F5 | 7(#11) |
| F#6 | F#/Gb | F#4 | M(9) | F#5 | dim7 |
| G6 | G | G4 | M6 | G5 | dim |
| Ab6 | Ab/G# | Ab4 | M7(9) | Ab5 | 7aug |
| A6 | A | A4 | M7 | A5 | aug |
| Bb6 | Bb/A# | Bb4 | M7b5 | Bb5 | 7sus4 |
| B6 | B | B4 | 7 | B5 | sus4 |

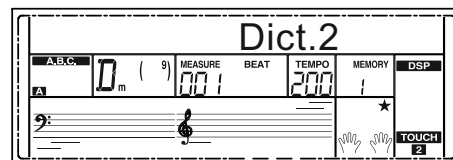
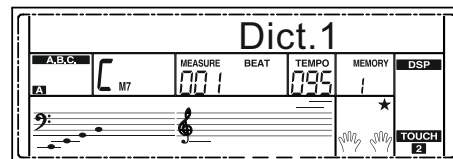
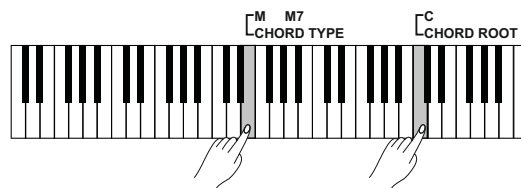
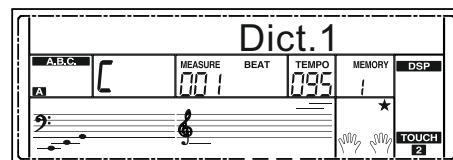
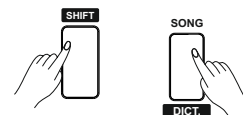

MIDI

With the MIDI functions you can expand your musical possibilities. This section will let you know what MIDI is, and what it can do, as well as how you can use MIDI on your instrument.

What's MIDI?

1. MIDI (short for Musical Instrument Digital Interface) allows a wide variety of electronic musical instruments, computers and other related devices to connect and communicate with one another. MIDI carries event messages that specify notation, pitch and velocity, control signals for parameters such as volume, vibrato, audio panning, and program change information to change the voice selections.
2. The instrument can output the real-time playback information via MIDI and control external MIDI devices. The instrument can also accept incoming MIDI messages and generate sound accordingly.

Note:

This instrument has a USB(DEVICE) terminal, which can be connected to a PC as an MIDI input or MIDI output. This can not be connected with another instrument, unless other USB host device with an USB terminal.

Upload/Download Data from the Computer

1. Connect a standard USB cable between the rear-panel USB jack on the instrument and the USB jack on your computer.
2. Power on the instrument first, and then open the PCSUITE software in your computer. If the LCD displays "PCLink.." it indicates the piano connects the PC successfully.
3. You can download 5 MIDI files to the keyboard as user songs or upload the user songs to PC.
4. You can upload user styles to the computer as a backup or download them to the keyboard. You can upload memory files to the computer as a backup or download them to the keyboard.
5. Please refer to software operation instructions for detail operating methods.

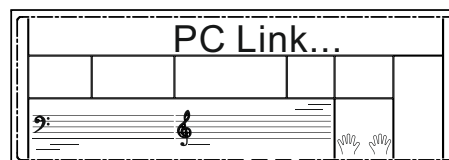
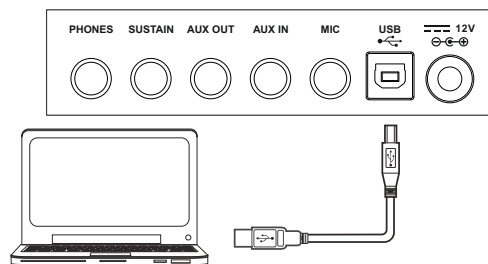

| Problem | Possible Cause and Solution |
|---|--|
| The speakers produce a pop sound whenever the power is turned ON or OFF. | This is normal and is no cause for alarm. |
| No sound when the keyboard is played. | The R1/R2/L voice volume (Mixer) settings could be set too low. Make sure the voice volumes are set at appropriate levels. |
| When using a mobile phone, noise is produced. | Using a mobile phone in close proximity to the instrument may produce interference. To prevent this, turn off the mobile phone or use it further away from the instrument. |
| The auto accompaniment does not play back even Sync is in standby condition and a key is pressed. | You may be trying to start accompaniment by playing a key in the right-hand range of the keyboard. To start the accompaniment with Sync Start, make sure to play a key in the left-hand range of the keyboard. |
| Certain notes sound at wrong pitch. | Make sure that the tuning value is set to 0. Press and hold the [+ / YES] and [- / NO] buttons at the same time, then turning the power on will set INSTRUMENT to default. |
| The Harmony function does not operate. | And Harmony cannot be turned on when a drum kit is selected for the voice R1. |

Notice:

If you notice any abnormality cannot handle, please connect the provider or specified repair station, and have the instrument inspected by qualified service personnel.

Specifications

LCD Display

Multi-functional LCD

Keys

61 Keys with Touch Response

Polyphony

128

Voices

618

Songs

150 Preset Songs and 5 User Songs

Styles

200 Preset Songs and 10 User Styles

Demos

5

Album

310

Tempo

30 – 280

Panel Memory

48

DSP

With DSP function, you can make your performance to be broader and fuller expression.

Chord Mode

Both single-finger mode and multi-finger mode.

Chord Dictionary

It is convenient for chord learning.

Accompaniment/Song Control

Start/Stop, Sync Start (Pause), Intro/Ending (Repeat A/B), Fill A (REW), Fill B (FF), Chord Mode, Fade.

Record

Record, Start/ Stop, Accomp Track, Melody Track 1~5

Control button

Power Switch, Volume Slider, Modulation Button, Pitch Bend, Style Direct Button 1~10, Shift, Tempo +/- (ACCMP +/-), Metronome (Octave), Mixer (Transpose), Harmony (Sustain), Start/ Stop, Sync Start (Pause), Intro/ Ending (Repeat), Fill A (REW), Fill B (FF), Chord (Fade), Bank (Record), Store (ACCOMP), Dual, Lower, Function, Smart Learning, M1~5(Melody1~5), M6 (Touch), O.T.S. (Perform.), Voice Direct Button 1~10, Voice, Style (Album), Song (Dict.), Piano (DSP), Demo, -/NO, +/Yes, Data Dial.

Connectors

PHONES, SUSTAIN, AUX OUT, AUX IN, MIC, USB, DC IN.

Power Supply

DC IN 12V/2000mA

Speaker

4 ohm 15Wx2

8 ohm 20Wx2

Dimensions

970(L) x370(W) x142(H) mm

Weight

6.75 KG

* All specifications and appearances are subject to change without notice.

Voice List

| No. | English Name | LCD Display |
|-----------------------------|---------------------------------|-------------|
| Piano | | |
| 1 | Acoustic Grand Piano | GrandPno |
| 2 | Acoustic Grand Piano 2 | GrandPn2 |
| 3 | Acoustic Grand Piano (wide) | GrandPnW |
| 4 | Acoustic Grand Piano (dark) | GrandPnD |
| 5 | Bright Acoustic Piano | BritePno |
| 6 | Bright Acoustic Piano 2 | BritePn2 |
| 7 | Bright Acoustic Piano (wide) | BritePnW |
| 8 | Electric Grand Piano | E.Grand |
| 9 | Electric Grand Piano 2 | E.Grand2 |
| 10 | Electric Grand Piano (wide) | E.GrandW |
| 11 | Electric Grand Piano (dark) | E.GrandD |
| 12 | Honky Tonk Piano | HnkyTonk |
| 13 | Honky Tonk Piano 2 | HnyTonk2 |
| 14 | Honky Tonk Piano (wide) | HnyTonkW |
| 15 | Honky Tonk Piano (dark) | HnyTonkD |
| 16 | Harpsichord | Harpsi |
| 17 | Harpsichord 2 | Harpsi2 |
| 18 | Harpsichord (octave mix) | HarpsiO |
| 19 | Harpsichord (wide) | HarpsiW |
| 20 | Harpsichord (with key off) | HarpsiOf |
| 21 | Octave Grand Piano | OctPno |
| 22 | Octave Grand Piano 2 | OctPno2 |
| 23 | Piano & Strings | Pno&Str |
| 24 | Piano & Pad | Pno&Pad |
| 25 | Piano & Choir | Pno&Cho |
| 26 | Piano & EP | Pno&EP |
| 27 | Piano & Vibraphone | Pno&Vib |
| 28 | Detuned Electric Piano | DetunEP |
| 29 | Detuned Electric Piano 2 | DetunEP2 |
| 30 | Electric Piano | E.Piano |
| 31 | Electric Piano 2 | E.Piano2 |
| 32 | Electric Piano 3 | E.Piano3 |
| 33 | Electric Piano 4 | E.Piano4 |
| 34 | Electric Piano 1 (velocity mix) | E.PnoV1 |
| 35 | Electric Piano 2 (velocity mix) | E.PnoV2 |
| 36 | 60's Electric Piano | 60'sEP |
| 37 | EP Legend | EPLegend |
| 38 | Phase EP | PhaseEP |
| 39 | Clavi | Clavi |
| 40 | Clavi 2 | Clavi2 |
| 41 | Phase Clavi | PhaseClv |
| 42 | Wah Clavi | WahClv |
| 43 | Pulse Clavi | PluseClv |
| 44 | Dream EP | DreamEP |
| 45 | Tremolo EP | TremoEP |
| 46 | Funk EP | FunkEP |
| 47 | Warm EP | WarmEP |
| 48 | Choir EP | ChoriEP |
| 49 | Wah EP | WahEP |
| 50 | Modern EP | ModernEP |
| 51 | EP Pad | EPPad |
| Chromatic Percussion | | |
| 52 | Celesta | Celesta |
| 53 | Celesta 2 | Celesta2 |

| | | |
|---------------|----------------------------|-----------|
| 54 | Celesta 3 | Celesta3 |
| 55 | Glockenspiel | Glocken |
| 56 | Glockenspiel 2 | Glocken2 |
| 57 | Music Box | MusicBox |
| 58 | Music Box 2 | MuscBox2 |
| 59 | Music Box 3 | MuscBox3 |
| 60 | Vibraphone | Vibra |
| 61 | Vibraphone 2 | Vibra2 |
| 62 | Vibraphone (wide) | VibraW |
| 63 | Marimba | Marimba |
| 64 | Marimba 2 | Marimba2 |
| 65 | Marimba (wide) | MarimbaW |
| 66 | Xylophone | Xylophon |
| 67 | Xylophone 2 | Xylopho2 |
| 68 | Xylophone 3 | Xylopho3 |
| 69 | Tubular Bells | TubulBel |
| 70 | Tubular Bells 2 | TubulBe2 |
| 71 | Church Bell | ChurBell |
| 72 | Carillon | Carillon |
| 73 | Dulcimer | Dulcimer |
| 74 | Dulcimer 2 | Dulcime2 |
| 75 | Santur | Santur |
| Organ | | |
| 76 | Italian 60's Organ | 60'sOrgn |
| 77 | Drawbar Organ | DrawOrgn |
| 78 | Drawbar Organ 2 | DrawOrg2 |
| 79 | Detuned Drawbar Organ | DeDraOrg |
| 80 | Drawbar Organ 3 | DrawOrg3 |
| 81 | Detuned Percussive Organ | DePerOrg |
| 82 | Percussive Organ | PercOrgn |
| 83 | Percussive Organ 2 | PercOrg2 |
| 84 | 70's Percussive Organ | 70'sPcOr |
| 85 | Percussive Organ 3 | PercOrg3 |
| 86 | Rock Organ | RockOrgn |
| 87 | Rock Organ 2 | RockOrg2 |
| 88 | Rock Organ 3 | RockOrg3 |
| 89 | Church Organ | ChurOrgn |
| 90 | Church Organ 2 | ChurOrg2 |
| 91 | Church Organ 3 | ChurOrg3 |
| 92 | Church Organ (octave mix) | ChurOrgO |
| 93 | Detuned Church Organ | DeChuOrg |
| 94 | Reed Organ | ReedOrgn |
| 95 | Reed Organ 2 | ReedOrg2 |
| 96 | Rotary Organ | RotyOrgn |
| 97 | Puff Organ | PuffOrgn |
| 98 | Accordion | Acordion |
| 99 | Accordion 2 | Acordin2 |
| 100 | Accordion 3 | Acordin3 |
| 101 | Harmonica | Harmnica |
| 102 | Harmonica 2 | Harmnic2 |
| 103 | Harmonica 3 | Harmnic3 |
| 104 | Tango Accordion | TangoAcCd |
| 105 | Tango Accordion 2 | TangAcCd2 |
| Guitar | | |
| 106 | Acoustic Guitar (nylon) | NylonGtr |
| 107 | Acoustic Guitar (nylon) 2 | NylonGt2 |

Voice List

| | | |
|-------------|-----------------------------------|----------|
| 108 | Acoustic Guitar (nylon) 3 | NylonGt3 |
| 109 | Acoustic Guitar (nylon + key off) | NylGtrOf |
| 110 | Ukulele | Ukulele |
| 111 | Acoustic Guitar (steel) | SteelGtr |
| 112 | Acoustic Guitar (steel) 2 | SteelGt2 |
| 113 | 12-Strings Guitar | 12StrGtr |
| 114 | Mandolin | Mandolin |
| 115 | Mandolin 2 | Mandoli2 |
| 116 | Steel Guitar with Body Sound | SteelBdy |
| 117 | Electric Guitar (jazz) | JazzGtr |
| 118 | Electric Guitar (jazz) 2 | JazzGtr2 |
| 119 | Electric Guitar (pedal steel) | PedalGtr |
| 120 | Electric Guitar (clean) | CleanGtr |
| 121 | Electric Guitar (clean) 2 | CleanGt2 |
| 122 | Electric Guitar (detuned clean) | DetClnGt |
| 123 | Mid Tone Guitar | MidTonGt |
| 124 | Electric Guitar (muted) | MutedGtr |
| 125 | Electric Guitar (muted) 2 | MutedGt2 |
| 126 | Electric Guitar (funky cutting) | FunkGt |
| 127 | Electric Guitar (muted velo-sw) | MutVelGt |
| 128 | Jazz Man | JazzMan |
| 129 | Overdriven Guitar | Ovrdrive |
| 130 | Overdriven Guitar 2 | Ovrdriv2 |
| 131 | Guitar Pinch | GtPinch |
| 132 | Distortion Guitar | DistGtr |
| 133 | Distortion Guitar 2 | DistGtr2 |
| 134 | Distortion Guitar (with feedback) | FeedbkGt |
| 135 | Guitar Feedback | GtrFdbk |
| 136 | Distorted Rhythm Guitar | DistRyth |
| 137 | Guitar Harmonics | GtrHarmo |
| 138 | Guitar Harmonics 2 | GtHarmo2 |
| 139 | Velocity Nylon Guitar | NyInGtVe |
| Bass | | |
| 140 | Acoustic Bass | AcoBass |
| 141 | Acoustic Bass 2 | AcoBass2 |
| 142 | Wah Bass | WahBass |
| 143 | Electric Bass (finger) | FngrBass |
| 144 | Finger Slap Bass | FngrSlap |
| 145 | Electric Bass (pick) | PickBass |
| 146 | Electric Bass (pick) 2 | PickBas2 |
| 147 | Fretless Bass | Fretless |
| 148 | Fretless Bass 2 | Fretles2 |
| 149 | Slap Bass | SlapBass |
| 150 | Slap Bass 2 | SlapBas2 |
| 151 | Slap Bass 3 | SlapBas3 |
| 152 | Slap Bass 4 | SlapBas4 |
| 153 | Synth Bass | SynBass |
| 154 | Synth Bass 2 | SynBass2 |
| 155 | Synth Bass 3 | SynBass3 |
| 156 | Synth Bass 4 | SynBass4 |
| 157 | Warm Synth Bass | WarmBass |
| 158 | Rsonance SynBass | ResoBass |
| 159 | Clavi Bass | ClavBass |
| 160 | Hammer | Hammer |
| 161 | Attack Bass | AtackBas |
| 162 | Synth Bass (rubber) | RubbBass |

| | | |
|---------------------------------|-----------------------|----------|
| 163 | Synth Bass (rubber) 2 | RubbBas2 |
| 164 | Attack Pulse | AtackPls |
| Strings & Orchestral | | |
| 165 | Violin | Violin |
| 166 | Violin 2 | Violin2 |
| 167 | Violin (slow attack) | SIViolin |
| 168 | Viola | Viola |
| 169 | Viola 2 | Viola2 |
| 170 | Cello | Cello |
| 171 | Cello 2 | Cello2 |
| 172 | Contrabass | Contrabs |
| 173 | Contrabass 2 | Contrbs2 |
| 174 | Tremolo Strings | TremStr |
| 175 | Tremolo Strings 2 | TremStr2 |
| 176 | Tremolo Strings 3 | TremStr3 |
| 177 | Pizzicato Strings | PizzStr |
| 178 | Pizzicato Strings 2 | PizzStr2 |
| 179 | Orchestral Harp | Harp |
| 180 | Orchestral Harp 2 | Harp2 |
| 181 | Yang Chin | YangChin |
| 182 | Timpani | Timpani |
| 183 | Timpani 2 | Timpani2 |
| 184 | String Ensembles | Strings |
| 185 | String Ensembles 2 | Strings2 |
| 186 | String Ensembles 3 | Strings3 |
| 187 | String Ensembles 4 | Strings4 |
| 188 | Strings & Brass | Str&Bras |
| 189 | 60's Strings | 60'sStr |
| 190 | Synth Strings | SynStrs |
| 191 | Synth Strings 2 | SynStrs2 |
| 192 | Synth Strings 3 | SynStrs3 |
| 193 | Synth Strings 4 | SynStrs4 |
| 194 | Synth Strings 5 | SynStrs5 |
| 195 | Choir Aahs | ChoirAah |
| 196 | Choir Aahs 2 | ChorAah2 |
| 197 | Choir Aahs 3 | ChorAah3 |
| 198 | Voice Oohs | VoiceOoh |
| 199 | Voice Oohs 2 | VoicOoh2 |
| 200 | Humming | Humming |
| 201 | Anlong Voice | AnlVoice |
| 202 | Synth Voice | SynVoice |
| 203 | Synth Voice 2 | SynVoic2 |
| 204 | Orchestra Hit | OrchHit |
| 205 | Orchestra Hit 2 | OrchHit2 |
| 206 | Bass Hit Plus | BassHit |
| 207 | 6th Hit | 6thHit |
| 208 | Euro Hit | EuroHit |
| Brass | | |
| 209 | Trumpet | Trumpet |
| 210 | Trumpet 2 | Trumpet2 |
| 211 | Dark Trumpet | DarkTrp |
| 212 | Trombone | Trombone |
| 213 | Trombone 2 | Trmbone2 |
| 214 | Trombone 3 | Trmbone3 |
| 215 | Bright Trombone | BritBone |
| 216 | Tuba | Tuba |

| | | |
|-------------|----------------------|------------|
| 217 | Tuba 2 | Tuba2 |
| 218 | Muted Trumpet | MuteTrp |
| 219 | Muted Trumpet 2 | MuteTrp2 |
| 220 | Muted Trumpet 3 | MuteTrp3 |
| 221 | French Horn | FrHorn |
| 222 | French Horn 2 | FrHorn2 |
| 223 | French Horn 3 | FrHorn3 |
| 224 | Brass Section | Brass |
| 225 | Brass Section 2 | Brass2 |
| 226 | Brass Section 3 | Brass3 |
| 227 | Synth Brass | SynBrass |
| 228 | Synth Brass 2 | SynBras2 |
| 229 | Synth Brass 3 | SynBras3 |
| 230 | Synth Brass 4 | SynBras4 |
| 231 | Synth Brass 5 | SynBras5 |
| 232 | Synth Brass 6 | SynBras6 |
| 233 | Synth Brass 7 | SynBras7 |
| 234 | Synth Brass 8 | SynBras8 |
| 235 | Analog Synth Brass | AnaBrass |
| 236 | Analog Synth Brass 2 | AnaBras2 |
| 237 | Analog Synth Brass 3 | AnaBras3 |
| 238 | Jump Brass | JumpBras |
| 239 | Jump Brass 2 | JumpBrs2 |
| 240 | Funny | Funny |
| 241 | Funny 2 | Funny2 |
| Reed | | |
| 242 | Soprano Sax | SprnoSax |
| 243 | Soprano Sax 2 | SprnSax2 |
| 244 | Soprano Sax 3 | SprnSax3 |
| 245 | Alto Sax | AltoSax |
| 246 | Alto Sax 2 | AltoSax2 |
| 247 | Alto Sax 3 | AltoSax3 |
| 248 | Tenor Sax | TenorSax |
| 249 | Tenor Sax 2 | TenoSax2 |
| 250 | Tenor Sax 3 | TenoSax3 |
| 251 | Baritone Sax | BariSax |
| 252 | Baritone Sax 2 | BariSax2 |
| 253 | Baritone Sax 3 | BariSax3 |
| 254 | Oboe | Oboe |
| 255 | Oboe 2 | Oboe2 |
| 256 | Oboe 3 | Oboe3 |
| 257 | 2 Oboes | 2Oboes |
| 258 | English Horn | EngHorn |
| 259 | English Horn 2 | EngHorn2 |
| 260 | English Horn 3 | EngHorn3 |
| 261 | 2 English Horns | 2EngHons |
| 262 | Bassoon | Bassoon |
| 263 | Bassoon 2 | Bassoon2 |
| 264 | Bassoon 3 | Bassoon3 |
| 265 | 2 Bassoons | 2Bassoons |
| 266 | Clarinet | Clarinet |
| 267 | Clarinet 2 | Clarinet2 |
| 268 | Clarinet 3 | Clarinet3 |
| 269 | 2 Clarinets | 2Clarinets |
| Pipe | | |
| 270 | Piccolo | Piccolo |

| | | |
|-------------------|------------------------------|-----------|
| 271 | Piccolo 2 | Piccolo2 |
| 272 | Piccolo 3 | Piccolo3 |
| 273 | 2 Piccolos | 2Piccolos |
| 274 | Sweet Flute | SweetFlut |
| 275 | Flute | Flute |
| 276 | Flute 2 | Flute2 |
| 277 | Flute 3 | Flute3 |
| 278 | 2 Flutes | 2Flutes |
| 279 | Recorder | Recorder |
| 280 | Recorder 2 | Recorder2 |
| 281 | 2 Recorders | 2Records |
| 282 | Pan Flute | PanFlute |
| 283 | Pan Flute 2 | PanFlut2 |
| 284 | Sweet Pan Flute | SwPanFlu |
| 285 | Blown Bottle | Bottle |
| 286 | Blown Bottle 2 | Bottle2 |
| 287 | Shakuhachi | Shakhchi |
| 288 | Shakuhachi 2 | Shakhch2 |
| 289 | Whistle | Whistle |
| 290 | Whistle 2 | Whistle2 |
| 291 | Ocarina | Ocarina |
| 292 | Ocarina 2 | Ocarina2 |
| Synth Lead | | |
| 293 | Lead 1 (square) | SquareLd |
| 294 | Lead 1a (square) 2 | SquarLd2 |
| 295 | Lead 1 (square) 3 | SquarLd3 |
| 296 | Lead 1b (sine) | SineLead |
| 297 | Lead 2 (sawtooth) | SawLead |
| 298 | Lead 2a (sawtooth) 2 | SawLead2 |
| 299 | Lead 2 (sawtooth) 3 | SawLead3 |
| 300 | Lead 2b (saw + pulse) | SawPlsLd |
| 301 | Lead 2c (double sawtooth) | DubSawLd |
| 302 | Lead 2d (sequenced analog) | SquAnaLd |
| 303 | Lead 2d (sequenced analog) 2 | SqAnaLd2 |
| 304 | Wavy Sawtooth | WavySaw |
| 305 | Bauble Lead | BaubleLd |
| 306 | Super Analog | SuperAna |
| 307 | Lead 3 (calliope) | CalliopLd |
| 308 | Lead 3 (calliope) 2 | CalipLd2 |
| 309 | Lead 4 (chiff) | ChiffLd |
| 310 | Lead 4 (chiff) 2 | ChiffLd2 |
| 311 | Lead 4 (chiff) 3 | ChiffLd3 |
| 312 | Lead 5 (charang) | CharanLd |
| 313 | Lead 5 (charang) 2 | CharaLd2 |
| 314 | Lead 5 (charang) 3 | CharaLd3 |
| 315 | Lead 5 (charang) 4 | CharaLd4 |
| 316 | Lead 5a (wire lead) | WireLead |
| 317 | Lead 5a (wire lead) 2 | WireLd2 |
| 318 | Lead 6 (voice) | VoiceLd |
| 319 | Lead 6 (voice) 2 | VoiceLd2 |
| 320 | Lead 7 (fifths) | FifthsLd |
| 321 | Lead 7 (fifths) 2 | FifthLd2 |
| 322 | Lead 8 (bass + lead) | BassLead |
| 323 | Lead 8 (bass + lead) 2 | BasLead2 |
| 324 | Lead 8 (bass + lead) 3 | BasLead3 |
| 325 | Lead 8a (soft wr) | SftWrLd |

Voice List

| | | |
|------------------|---------------------|----------|
| 326 | Massiness | Massin |
| 327 | Square | Square |
| 328 | Slow Square Lead | SlwSquLd |
| 329 | Sine Solo | SineSolo |
| 330 | Square Lead 4 | SquarLd4 |
| 331 | Thick Square | ThickSqu |
| 332 | 2Oscillators Lead | 2OscLd |
| 333 | Wavy Sawtooth 2 | WavySaw2 |
| 334 | Analog Lead | AnaLead |
| 335 | Big Lead | BigLead |
| 336 | Fat Lead | FatLead |
| 337 | PWM 4th | Rezz4th |
| 338 | Delayed Lead | DelyLead |
| 339 | Delayed Lead 2 | DlyLead2 |
| 340 | Fifth Lead | FifLead |
| 341 | Corrie | Corrie |
| 342 | Quint | Quint |
| Synth Pad | | |
| 343 | Pad 1 (new age) | NewAge |
| 344 | Pad 1 (new age) 2 | NewAge2 |
| 345 | Pad 2 (warm) | WarmPad |
| 346 | Pad 2 (warm) 2 | WarmPad2 |
| 347 | Pad 2a (sine pad) | SinePad |
| 348 | Pad 3 (polysynth) | PolySyn |
| 349 | Pad 3 (polysynth) 2 | PolySyn2 |
| 350 | Pad 3 (polysynth) 3 | PolySyn3 |
| 351 | Pad 3 (polysynth) 4 | PolySyn4 |
| 352 | Pad 4 (choir) | ChoirPad |
| 353 | Pad 4 (choir) 2 | ChoirPd2 |
| 354 | Pad 4a (itopia) | ItopiaPd |
| 355 | Pad 5 (bowed) | BowedPad |
| 356 | Pad 5 (bowed) 2 | BowedPd2 |
| 357 | Pad 6 (metallic) | MetalPad |
| 358 | Pad 6 (metallic) 2 | MetalPd2 |
| 359 | Pad 7 (halo) | HaloPad |
| 360 | Pad 7 (halo) 2 | HaloPad2 |
| 361 | Pad 8 (sweep) | SweepPad |
| 362 | Pad 8 (sweep) 2 | SweepPd2 |
| 363 | Pad 8 (sweep) 3 | SweepPd3 |
| 364 | Pan Pad | PanPad |
| 365 | Pan Pad 2 | PanPad2 |
| 366 | Dipolar Pad | DipolPad |
| 367 | PWM Pad | PWMPad |
| 368 | Warmly Pad | WarmlyPd |
| 369 | Horn Pad | HornPad |
| 370 | Click Pad | ClickPad |
| 371 | Analog Pad | AnalogPd |
| 372 | 80's Poly Pad | 80'sPoly |
| 373 | PWM 4th Soft | PWM4thSf |
| 374 | Synth Calliope Soft | SynCalSf |
| 375 | Soft Vox | SoftVox |
| 376 | 5th SawWave | 5thSaw |
| 377 | 5th Lead Soft | 5thLdSf |
| 378 | Slow Square | SISquare |
| 379 | New Year Pad | NewYear |
| 380 | Space Voice | SpcVoice |

| | | |
|---------------------|----------------------|----------|
| 381 | Rising | Rising |
| 382 | Congregate | Congrega |
| Synth SFX | | |
| 383 | FX 1 (rain) | FXRain |
| 384 | FX 1 (rain) 2 | FXRain2 |
| 385 | FX 2 (soundtrack) | Soundtrk |
| 386 | FX 2 (soundtrack) 2 | Sondtrk2 |
| 387 | Prelude | Prelude |
| 388 | FX 3 (crystal) | Crystal |
| 389 | FX 3 (crystal) 2 | Crystal2 |
| 390 | FX 3a (synth mallet) | SynMalet |
| 391 | FX 4 (atmosphere) | Atmosphr |
| 392 | FX 4 (atmosphere) 2 | Atmosph2 |
| 393 | Warm Air | WarmAir |
| 394 | FX 5 (brightness) | Bright |
| 395 | Smog | Smog |
| 396 | FX 6 (goblins) | Goblins |
| 397 | FX 6 (goblins) 2 | Goblins2 |
| 398 | Choir Bell | ChorBell |
| 399 | Choir Bell 2 | ChorBel2 |
| 400 | FX 7 (echoes) | Echoes |
| 401 | FX 7 (echoes) 2 | Echoes2 |
| 402 | FX 7b (echo pan) | EchoPan |
| 403 | FX 7a (echo bell) | EchoBell |
| 404 | FX 7a (echo bell) 2 | EchoBel2 |
| 405 | FX 7a (echo bell) 3 | EchoBel3 |
| 406 | FX 8 (sci-fi) | Sci-Fi |
| 407 | FX 8 (sci-fi) 2 | Sci-Fi2 |
| Ethnic Misc. | | |
| 408 | Sitar | Sitar |
| 409 | Sitar 2 | Sitar2 |
| 410 | Banjo | Banjo |
| 411 | Banjo 2 | Banjo2 |
| 412 | Shamisen | Shamisen |
| 413 | Shamisen 2 | Shamise2 |
| 414 | Koto | Koto |
| 415 | Koto 2 | Koto2 |
| 416 | Taisho Koto | TaishoKt |
| 417 | Kalimba | Kalimba |
| 418 | Kalimba 2 | Kalimba2 |
| 419 | Bag Pipe | BagPipe |
| 420 | Bag Pipe 2 | BagPipe2 |
| 421 | Fiddle | Fiddle |
| 422 | Fiddle 2 | Fiddle2 |
| 423 | Fiddle 3 | Fiddle3 |
| 424 | Shanai | Shanai |
| 425 | Shanai 2 | Shanai2 |
| Percussive | | |
| 426 | Tinkle Bell | TnkIBell |
| 427 | Agogo | Agogo |
| 428 | Agogo 2 | Agogo2 |
| 429 | Agogo 3 | Agogo3 |
| 430 | Steel Drums | SteelDrm |
| 431 | Steel Drums 2 | StelDrm2 |
| 432 | Woodblock | WoodBlok |
| 433 | Woodblock 2 | WodBlok2 |

| | | |
|-----|----------------------|----------|
| 434 | Castanets | Castanet |
| 435 | Castanets 2 | Castant2 |
| 436 | Taiko Drum | TaikoDrm |
| 437 | Taiko Drum 2 | TaikDrm2 |
| 438 | Taiko Drum 3 | TaikDrm3 |
| 439 | Concert Bass Drum | ConBasDm |
| 440 | Concert Bass Drum 2 | ConBsDm2 |
| 441 | Acoustic Bass Drum | BassDrum |
| 442 | Room Kick | RoomKick |
| 443 | Power Kick | PowrKick |
| 444 | Electric Bass Drum | EIBsDrum |
| 445 | Analog Bass Drum | AnBsDrum |
| 446 | Jazz Kick | JazzKick |
| 447 | Side Stick | SidStick |
| 448 | Analog Rim Shot | AnRiShot |
| 449 | Acoustic Snare | A.Snare |
| 450 | Room Snare | RomSnare |
| 451 | Power Snare | PowSnare |
| 452 | Electric Snare | E.Snare |
| 453 | Analog Snare | AnaSnare |
| 454 | Jazz Snare | JazSnare |
| 455 | Brush Tap | BrushTap |
| 456 | Concert SD | ConcetSD |
| 457 | Hand Clap | HandClap |
| 458 | Tom | Tom |
| 459 | Room Tom | RoomTom |
| 460 | Power Tom | PowerTom |
| 461 | Electric Tom | ElecTom |
| 462 | Analog Tom | AnaTom |
| 463 | Brush Tom | BrushTom |
| 464 | Closed Hi-hat | ClosedHH |
| 465 | Analog Closed Hi-hat | AnCloHH |
| 466 | Pedal Hi-hat | PedalHH |
| 467 | Open Hi-hat | OpenHH |
| 468 | Crash Cymbal | CrashCym |
| 469 | Analog Cymbal | AnaCym |
| 470 | Ride Cymbal | RideCym |
| 471 | China Cymbal | ChinaCym |
| 472 | Ride Bell | RideBell |
| 473 | Tambourine | Tambouri |
| 474 | Splash Cymbal | SplashCy |
| 475 | Cowbell | Cowbell |
| 476 | Analog Cowbell | AnaCowbl |
| 477 | High Bongo | HiBongo |
| 478 | Low Bongo | LoBongo |
| 479 | Mute Hi Conga | MuHiCnga |
| 480 | Open Hi Conga | OpHiCnga |
| 481 | Low Conga | LowConga |
| 482 | Analog Hi Conga | AnHiCnga |
| 483 | Analog Mid Conga | AnMiCnga |
| 484 | Analog Low Conga | AnLoCnga |
| 485 | High Timbale | HiTimbal |
| 486 | Low Timbale | LoTimbal |
| 487 | Cabasa | Cabasa |
| 488 | Maracas | Maracas |

| | | |
|------------|---------------------------|-----------|
| 489 | Analog Maracas | AnMaraca |
| 490 | Short Guiro | ShGuiro |
| 491 | Long Guiro | LoGuiro |
| 492 | Claves | Claves |
| 493 | Mute Cuica | MuCuica |
| 494 | Open Cuica | OpCuica |
| 495 | Mute Triangle | MuTrgle |
| 496 | Open Triangle | OpTrgle |
| 497 | Shaker | Shaker |
| 498 | Mute Surdo | MuSurdo |
| 499 | Open Surdo | OpSurdo |
| 500 | Melodic Tom | MeloTom |
| 501 | Melodic Tom 2 | MeloTom2 |
| 502 | Synth Drum | SynDrum |
| 503 | Rhythm Box Tom | RhythBox |
| 504 | Electric Drum | ElecDrum |
| 505 | Reverse Cymbal | RevCymb1 |
| SFX | | |
| 506 | Guitar Fret Noise | FretNoiz |
| 507 | Guitar Cutting Noise | GtCtNoiz |
| 508 | Acoustic Bass String Slap | BsStSlap |
| 509 | Breath Noise | BrthNoiz |
| 510 | Flute Key Click | FlKeyClk |
| 511 | Seashore | Seashore |
| 512 | Rain | Rain |
| 513 | Thunder | Thunder |
| 514 | Wind | Wind |
| 515 | Stream | Stream |
| 516 | Bubble | Bubble |
| 517 | Bird Tweet | Tweet |
| 518 | Bird Tweet 2 | Tweet2 |
| 519 | Dog | Dog |
| 520 | Horse Gallop | HouseGlp |
| 521 | Telephone Ring | Telephone |
| 522 | Telephone Ring 2 | Telphon2 |
| 523 | Door Creaking | DoorCrek |
| 524 | Door | Door |
| 525 | Scratch | Scratch |
| 526 | Wind Chime | WindChim |
| 527 | Helicopter | Helicptr |
| 528 | Car Engine | CarEngin |
| 529 | Car Stop | CarStop |
| 530 | Car Pass | CarPass |
| 531 | Car Crash | CarCrash |
| 532 | Siren | Siren |
| 533 | Train | Train |
| 534 | Jetplane | Jetplane |
| 535 | Starship | Starship |
| 536 | Burst Noise | BurtNois |
| 537 | Applause | Applause |
| 538 | Laughing | Laughing |
| 539 | Screaming | Scream |
| 540 | Punch | Punch |
| 541 | Heart Beat | HeartBet |
| 542 | Footsteps | Footstep |
| 543 | Gunshot | Gunshot |

Voice List

| | | |
|-----------------------|--------------------------------|----------|
| 544 | Machine Gun | MachnGun |
| 545 | Lasergun | Lasergun |
| 546 | Explosion | Explosio |
| Combined Voice | | |
| 547 | Stereo Piano & Strings Pad | Pn&StrPd |
| 548 | Stereo Piano & Choir | Pn&Choir |
| 549 | Stereo Piano & Synth Strings | Pn&SyStr |
| 550 | Stereo Piano & Warm Pad | Pn&WrmPd |
| 551 | Stereo Piano & Soft EP | Pn&SfEP |
| 552 | FM Electric Piano | FMEP |
| 553 | Digital Piano | DigitlPn |
| 554 | E.Piano & Strings | EP&Str |
| 555 | E.Piano & Acoustic Guitar | EP&Gtr |
| 556 | E.Piano & Vibraphone | EP&Vibra |
| 557 | E.Piano 2 & Pad | EP2&Pad |
| 558 | E.Piano 2 & Strings | EP2&Str |
| 559 | Harpsichord & Stereo Strings | Hrps&Str |
| 560 | Music Box & Stereo Strings | MBox&Str |
| 561 | Vibraphone & Stereo Strings | Vib&Str |
| 562 | Vibraphone Octave | VibraOct |
| 563 | Vibraphone & Marimba & Kalimba | Vib&M&K |
| 564 | Marimba & Kalimba | Mar&Kal |
| 565 | Marimba Delay | MarDelay |
| 566 | Xylophone Octave | XylopOct |
| 567 | Organ & Stereo Strings | Orgn&Str |
| 568 | Stereo Organ & Piano | Orgn&Pno |
| 569 | Rock Organ & Strings | RkOr&Str |
| 570 | Church Organ & Choir | ChOr&Cho |
| 571 | Church Organ & Strings | ChOr&Str |
| 572 | Acoustic Guitar & Flute | Gtr&Flut |
| 573 | Acoustic Guitar & Clavi | Gtr&Clav |
| 574 | 24 String Guitar | 24StrGtr |
| 575 | Steel Guitar & Warm Pad | StGt&Pad |
| 576 | Stereo Strings & Horn | Str&Horn |
| 577 | Orchestra | Orchestr |
| 578 | Full Strings | FullStr |
| 579 | Full Strings 2 | FullStr2 |
| 580 | Symphonic | Symphon |
| 581 | Stereo Choir & Strings | Cho&Str |
| 582 | Stereo Choir & Steel Guitar | Cho&Gtr |
| 583 | 3 Trumpet Loose | 3Trumpet |
| 584 | Trombone & Stereo Strings | Tomb&Str |
| 585 | 3 Trombones Loose | 3Trmbone |
| 586 | 3 Muted Trumpets Loose | 3MuTrump |
| 587 | Club Brass | ClubBras |
| 588 | Brass & Woodwinds | Brs&Wood |
| 589 | Woodwinds & Strings | Wood&Str |
| 590 | Section Woods Small | WoodSmal |
| 591 | Pan Flute & Strings Pad | PnFl&Str |
| 592 | Koto & Shamisen | Kto&Sham |
| 593 | Flute & Clarinet | Flu&Clar |
| 594 | Flute & Oboe | Flu&Oboe |
| 595 | Flute & Bassoon | Flu&Bn |
| 596 | Flute & Oboe & Clarinet | Fl&Ob&Cl |
| 597 | Flute & Clarinet & Bassoon | Fl&Cl&Bn |

| | | |
|--------------|---------------------------|----------|
| 598 | Flute & Oboe & Bassoon | Fl&Ob&Bn |
| 599 | Flute Octave | FluteOct |
| 600 | Flute & Oboe Octave | Fl&ObOct |
| 601 | Flute & Clarinet Octave | Fl&ClOct |
| 602 | Oboe & Bassoon | Oboe&Bn |
| 603 | Oboe & Clarinet | Ob&Cl |
| 604 | Oboe & Clarinet & Bassoon | Ob&Cl&Bn |
| 605 | Oboe Octave | OboeOct |
| 606 | Oboe & Clarinet Octave | Ob&ClOct |
| 607 | Oboe & Bassoon Octave | Ob&BnOct |
| 608 | Clarinet & Bassoon | Cl&Bn |
| 609 | Clarinet & Oboe Octave | Cl&ObOct |
| Drums | | |
| 610 | Standard Set | StandSet |
| 611 | Room Set | RoomSet |
| 612 | Power Set | PowerSet |
| 613 | Electronic Set | ElectSet |
| 614 | Analog Set | AnalgSet |
| 615 | Jazz Set | JazzSet |
| 616 | Brush Set | BrushSet |
| 617 | Orchestra Set | OrcheSet |
| 618 | SFX Set | SFXSet |

Style List

| No. | English Name | LCD Display |
|-------------------------|------------------|-------------|
| 8BEAT | | |
| 1 | 8Beat Ballad | 8BtBld |
| 2 | 8Beat Piano | 8BtPiano |
| 3 | 8Beat 1 | 8Beat1 |
| 4 | Guitar Pop 1 | GtPop1 |
| 5 | 8Beat Hip Hop | 8BtHiHop |
| 6 | 8Beat Blues Rock | 8BtBluRk |
| 7 | 8Beat 2 | 8Beat2 |
| 8 | Sweet Beat | SweetBt |
| 9 | 8Beat 3 | 8Beat3 |
| 10 | Rhythm&Beat 2 | Rhy&Bt2 |
| 16BEAT | | |
| 11 | 16Beat 1 | 16Beat1 |
| 12 | 16Beat Funk 1 | 16BtFuk1 |
| 13 | 16Beat Ballad 1 | 16BtBld1 |
| 14 | 16Beat R&B | 16BtR&B |
| 15 | Pop 16Beat 1 | Pop16Bt1 |
| 16 | 16Beat Funk 2 | 16BtFuk2 |
| 17 | 16Beat Dance | 16BtDanc |
| 18 | Pop 16Beat 2 | Pop16Bt2 |
| 19 | 16Beat 2 | 16Beat2 |
| 20 | Pop 16Beat 3 | Pop16Bt3 |
| 21 | Pop 16Beat 4 | Pop16Bt4 |
| 22 | Modern 16Beat | Modr16Bt |
| 23 | 16Beat Hot | 16BtHot |
| 24 | 16Beat Modern | 16BtModr |
| 25 | 16Beat Funk 3 | 16BtFuk3 |
| 26 | 16Beat 3 | 16Beat3 |
| 27 | Cool Beat | CoolBeat |
| 28 | 16Beat Ballad 2 | 16BtBld2 |
| 29 | 16Beat 4 | 16Beat4 |
| 30 | Pop Shuffle | PopShfl |
| POP & BALLAD | | |
| 31 | Pop Rock 1 | PopRock1 |
| 32 | Pop Dance 1 | PopDanc1 |
| 33 | Pop Fusion | PopFusn |
| 34 | Analog Night 1 | AnalgNt1 |
| 35 | 6/8 Pop | 6/8Pop |
| 36 | Brit. Pop 1 | BritPop1 |
| 37 | Brit. Pop 2 | BritPop2 |
| 38 | Pop Hit | PopHit |
| 39 | Fusion Shuffle | FusShfl |
| 40 | Analog Night 2 | AnalgNt2 |
| 41 | Guitar Pop 3 | GtPop3 |
| 42 | Pop Beat | PopBeat |
| 43 | Soft Beat | SoftBeat |
| 44 | 60's Pop | 60'sPop |
| 45 | Sting Latin | StigLatn |
| 46 | R&B Ballad 1 | R&BBld1 |
| 47 | Guitar Ballad | GtBallad |
| 48 | Ballad Rock | BaldRock |
| 49 | Piano Pop | PianoPop |
| 50 | Soft Ballad | SoftBald |

| | | |
|-----------------|----------------|----------|
| 51 | Natural Ballad | NatuIBld |
| 52 | Love Ballad | LoveBald |
| 53 | Easy Ballad | EasyBald |
| 54 | Miami Folk | MiamiBld |
| 55 | Slow Ballad | SlowBald |
| 56 | Folk Ballad | FolkBald |
| 57 | Pop Ballad 1 | PopBald1 |
| 58 | Pop Ballad 2 | PopBald2 |
| 59 | EP Ballad | EPBallad |
| 60 | New R&B Ballad | NewRBBld |
| ROCK | | |
| 61 | Rock | Rock |
| 62 | New Wave | NewWave |
| 63 | Ska | Ska |
| 64 | Pop Rock 2 | PopRock2 |
| 65 | Slow Rock | SlowRock |
| 66 | 70's Rock&Roll | 70'sRock |
| 67 | Folk Rock | FolkRock |
| 68 | Soft Rock | SoftRock |
| 69 | Old Rock | OldRock |
| 70 | Easy Rock | EasyRock |
| 71 | New Shuffle | NewShfl |
| 72 | Rock Hip Hop | RkHipHop |
| 73 | Rock&Roll 1 | R'N'R1 |
| 74 | Rock Shuffle | RockShfl |
| 75 | Rock&Roll 2 | R'N'R2 |
| BALLROOM | | |
| 76 | Tango 1 | Tango1 |
| 77 | Spain Matador | Matador |
| 78 | Twist 1 | Twist1 |
| 79 | Twist 2 | Twist2 |
| 80 | Big Band Fox | BandFox |
| 81 | Tango 2 | Tango2 |
| 82 | Slow Fox | SlowFox |
| 83 | Slow Waltz 1 | SlowWlz1 |
| 84 | Swing Fox | SwingFox |
| 85 | Salsa 1 | Salsa1 |
| 86 | Cha Cha 1 | ChaCha1 |
| 87 | Cha Cha 2 | ChaCha2 |
| 88 | Beguine 1 | Beguine1 |
| 89 | Beguine 2 | Beguine2 |
| 90 | Rumba 1 | Rumba1 |
| 91 | Samba 1 | Samba1 |
| 92 | Samba 2 | Samba2 |
| 93 | Jive | Jive |
| 94 | Fox Trot | FoxTrot |
| DANCE | | |
| 95 | Techno 1 | Techno1 |
| 96 | Hip Hop 1 | HipHop1 |
| 97 | House 1 | House1 |
| 98 | Down Beat | DownBeat |
| 99 | Progressive | Progress |
| 100 | Rap 1 | Rap1 |
| 101 | Disco | Disco |

Style List

| | | |
|--------------------------------|---------------------|----------|
| 102 | 70's Disco | 70'sDisc |
| 103 | Club Dance | ClubDanc |
| 104 | Euro Dance | EuroDanc |
| 105 | Garage | Garage |
| SOUL & FUNK | | |
| 106 | Funk 1 | Funk1 |
| 107 | Classic Funk | ClasFunk |
| 108 | Jay R&B | JayR&B |
| 109 | Gospel Swing | GopSwing |
| 110 | Gospel | Gospel |
| 111 | Funk 2 | Funk2 |
| 112 | Electric Funk | ElecFunk |
| 113 | Groove Funk | GrooveFk |
| 114 | Rubber Funk | RubberFk |
| 115 | Cool Funky | ColFunky |
| 116 | Jazz Funk | JazzFunk |
| 117 | Groove | Groove |
| 118 | Soul | Soul |
| 119 | Hip Hop Soul | HipHopSl |
| 120 | Hip Hop Beat | HipHopBt |
| 121 | R&B | R&B |
| 122 | British Soul Pop | BritSoul |
| 123 | Latin Jazz 1 | LatinJz1 |
| 124 | Big Band 1 | BigBand1 |
| 125 | Dixieland 1 | Dixland1 |
| 126 | Guitar Swing 1 | GtSwing1 |
| 127 | Broadway Big Band | BwayBand |
| 128 | Swing | Swing |
| 129 | Latin Jazz 2 | LatinJz2 |
| 130 | Fusion | Fusion |
| 131 | Acid Jazz | AcidJazz |
| 132 | Cool Jazz Ballad | CoolJzBd |
| 133 | Swing Shuffle | SwingSfl |
| 134 | Big Band Medium | BandMid |
| 135 | Ragtime | Ragtime |
| COUNTRY | | |
| 136 | Country Pop 1 | CntyPop1 |
| 137 | Bluegrass 1 | Blugras1 |
| 138 | 8Beat Country | 8BtCnty |
| 139 | Modern Country | ModrCnty |
| 140 | Country Pop 2 | CntyPop2 |
| 141 | Bluegrass 2 | Blugras2 |
| 142 | 2/4 Country | 2/4Cntry |
| 143 | Country Quick Steps | QuickStp |
| 144 | Country Folk | CntyFolk |
| 145 | Country Shuffle | CnyShuff |
| LATIN & LATIN DANCE | | |
| 146 | Samba 3 | Samba3 |
| 147 | Bossa Nova | BosaNova |
| 148 | Latin | Latin |
| 149 | New Reggae | NewRegga |
| 150 | Reggae Dance | DanRegga |
| 151 | Paso Doble | Pasodobl |
| 152 | Lite Bossa | LteBossa |

| | | |
|--------------------------------|-----------------|----------|
| 153 | Latin Rock | LatinRck |
| 154 | Beguine 3 | Beguine3 |
| 155 | Slow Bolero | SBolero |
| 156 | Disco Samba | DscSamba |
| 157 | Mambo | Mambo |
| 158 | Meneito | Meneito |
| 159 | Rumba 2 | Rumba2 |
| 160 | Rumba 3 | Rumba3 |
| 161 | Lambada | Lambada |
| 162 | Pop Cha Cha 1 | PChaCha1 |
| WALTZ & TRADITIONAL | | |
| 163 | Waltz | Waltz |
| 164 | Old Waltz | OldWaltz |
| 165 | English Waltz | EngWaltz |
| 166 | German Waltz | GemWaltz |
| 167 | Italian Mazurka | ItaMazuk |
| 168 | Mexico Waltz | MexWaltz |
| 169 | Vienna Waltz | VinaWltz |
| 170 | Slow Waltz 2 | SlwWltz2 |
| 171 | Jazz Waltz | JazzWltz |
| 172 | Polka | Polka |
| 173 | 6/8 March | 6/8March |
| 174 | German Polka | GemPolka |
| 175 | Party Polka | PtyPolka |
| 176 | Army March | ArmMarch |
| 177 | March | March |
| 178 | US March | USMarch |
| 179 | French Musette | FMusette |
| 180 | Mazurka | Mazurka |
| WORLD | | |
| 181 | Enka Ballad | EnkaBald |
| 182 | Laendler | Laendler |
| 183 | Hawaiian | Hawaiian |
| 184 | Sirtake | Sirtake |
| 185 | Dangdut | Dangdut |
| 186 | 6/8 Flipper | 6/8Flipp |
| 187 | New Age | NewAge |
| 188 | Tarantella | Tarantel |
| 189 | Scottish | Scottish |
| 190 | Norteno | Norteno |
| PIANIST | | |
| 191 | Pianist 1 | Pianist1 |
| 192 | Pianist 2 | Pianist2 |
| 193 | Pianist 3 | Pianist3 |
| 194 | Piano Rock | PianoRk |
| 195 | Pop Bossa | PopBossa |
| 196 | Piano Beat | PianoBt |
| 197 | Piano Bar | PianoBar |
| 198 | Blues | Blues |
| 199 | Pop Waltz | PopWaltz |
| 200 | 6/8 Ballad | 6/8Bald |

Song List

| No. | English Name | LCD Display |
|---------------------------|------------------------------|-------------|
| FOLK & COUNTRY | | |
| 1 | Toccata | Toccata |
| 2 | Carry Me Back To Old Virginy | Virginy |
| 3 | El Condor Pasa | ElCondor |
| 4 | Wedding March | Wedding |
| 5 | Traumerei | Traumere |
| 6 | Greensleeves | Sleeves |
| 7 | Home Sweet Home | SwetHome |
| 8 | Aloha Oe | AlohaOe |
| 9 | Long Long Ago | LongAgo |
| 10 | Heidenroslein | Heidenro |
| 11 | Die Lorelei | Lorelei |
| 12 | My Darling Clementine | Clemtine |
| 13 | Over The Waves | OverWave |
| 14 | Gwine To Run All Night | Gwine |
| 15 | Oh! Susanna | Susanna |
| 16 | Symphony No.6 "Pathetic" | Sympony6 |
| 17 | Prelude Op.28 No.15 | Prelude |
| 18 | The House Of The Rising Sun | RiseSun |
| GOLDEN & POP | | |
| 19 | Valse Des Fleurs | Fleurs |
| 20 | Fruhlingsstimmen | Fruhling |
| 21 | Frohlicher Landmann | Landmann |
| 22 | Are You Lonesome Tonight? | Lonesome |
| 23 | Toy Symphony | ToySymph |
| 24 | Auld Lang Syne | LangSyne |
| 25 | Ave Maria | AveMaria |
| 26 | Tales Of Hoffman | Hoffman |
| 27 | La Donne Mobile | DoneMble |
| 28 | Serenata | Serenata |
| 29 | Bridal March | Bridal |
| 30 | Can'T Help Fallin' In Love | InLove |
| 31 | Chanson Du Toreador | Toreador |
| 32 | Danny Boy | DannyBoy |
| 33 | Ich Liebe Dich | LieDich |
| 34 | Wiegenlied 2 | Wieglied2 |
| 35 | Spanish Serenade | Serenade |
| 36 | Piano Concerto | Concerto |
| 37 | Piano Concerto 2 | Concrto2 |
| 38 | Madame Butterfly | Madame |
| 39 | Invitation To The Dance | ToDance |
| 40 | Wiegenlied 3 | Wieglied3 |
| 41 | Jingle Bells | JingBell |
| 42 | Joy To The World | JoyWorld |
| 43 | La Paloma | LaPaloma |
| 44 | My Bonnie | MyBonnie |
| 45 | La Reine De Saba | Saba |
| 46 | La Cucaracha | Cucarach |
| 47 | Little Brown Jug | BrownJug |
| 48 | Battle Hymne Of The Republic | BatlHyme |
| 49 | Yellow Rose Of Texas | YellRose |
| 50 | The Wabash Cannon Ball | CannBall |

| No. | English Name | LCD Display |
|------------------|---|-------------|
| 51 | Annie Laurie | AnnieLa |
| 52 | Turkish March | Turkish |
| 53 | An Die Musik | Musik |
| 54 | Lieder Ohne Worte Op.62 No.6 | Lieder |
| 55 | Red River Valley | RedRiver |
| 56 | Die Forelle | Forelle |
| 57 | Symphony No. 94 "Suprise" | No. 94 |
| 58 | Polonaise | Polonais |
| 59 | Rondeau | Rondeau |
| 60 | Moments Musicaux | Musicaux |
| 61 | Silent Night | SltNight |
| 62 | Moldau | Moldau |
| 63 | Summertime | Summer |
| 64 | Dreaming Of Home And Mother | Dreaming |
| 65 | Ring Ring De Banjo | DeBanjo |
| 66 | Der Lindenbaum | DerLinde |
| 67 | Zigeunerweisen | Zigeuner |
| 68 | The Maiden's Prayer | Prayer |
| 69 | Fur Elise | FurElise |
| 70 | Der Freischutz | DerFreis |
| 71 | Maria! Mari! | Maria! |
| 72 | Heidenroslein | Heidenro |
| 73 | Symphony No.5 | Symphony |
| 74 | Anitra's Dance | Anitra |
| 75 | Sadko-Chanson Indoue | Chanson |
| 76 | Orpheus | Orpheus |
| CLASSICAL | | |
| 77 | William Tell Overture | Overture |
| 78 | A Lover's Concerto | Concerto |
| 79 | Air For The G-String | G-String |
| 80 | An Der Shonen Blauen Donau | Donau |
| 81 | Auf Flugeln Des Gesanges | Gesanges |
| 82 | Beautiful Dreamer | Dreamer |
| 83 | Dance Des Mirlitons | Mirliton |
| 84 | Etude Op. 10 No. 3 | Etude3 |
| 85 | Gavotte | Gavotte |
| 86 | Hungarian Dances No. 5 | Hungaian |
| 87 | From The New World | NewWorld |
| 88 | Serenata Rimpiant | Serenata |
| 89 | Triumphal March | Trimphal |
| 90 | The Skaters Waltz | Skaters |
| 91 | O Sole Mio | OSoleMio |
| 92 | Waves Of The Danube | Danube |
| 93 | Santa Lucia | SantaLuc |
| 94 | Solveig's Song | Solveig |
| 95 | Piano Sonatan No. 8 In C Minor (Pathetique) | Patheque |
| 96 | Brahms Waltz | BrmsWltz |
| 97 | Aida | Aida |
| 98 | Carmen-Prelude | Carmen |
| 99 | L'Arlesienne | L'Arlesi |
| 100 | Ungarische Tanz | Ungaris |
| 101 | Mazurka | Mazurka |

Song List

| No. | English Name | LCD Display |
|--------------|--|-------------|
| 102 | Pizzicato Polka | Polka |
| 103 | Menuett | Menuett |
| 104 | Rigoletto | Rigoletto |
| 105 | Serenade | Serenade |
| 106 | Song Without Words | SongNoWd |
| 107 | Swan | Swan |
| 108 | The Dying Swan | DyingSwn |
| 109 | Swan Lake Valse | SwnWalse |
| 110 | The Happy Farmer | HpFarmer |
| 111 | The Sleeping Beauty | SleepBty |
| 112 | La Traviata | LaTravia |
| 113 | Wiegenlied | Wiegenli |
| 114 | Mov. 2 Adagio Non Troppo Piano Sonata No. 9 In D | Sonata9 |
| 115 | Piano Sonata No. 11 In A | Sonata11 |
| 116 | Prelude In C | Prelude |
| 117 | Chinese Dance | ChDance |
| 118 | Emperor Waltz | Emperor |
| 119 | March Militaire | Militair |
| 120 | Symphony No. 40 | Symphony |
| PIANO | | |
| 121 | Hanon Piano Fingering 1 | Hanon1 |
| 122 | Hanon Piano Fingering 2 | Hanon2 |
| 123 | Hanon Piano Fingering 3 | Hanon3 |
| 124 | Hanon Piano Fingering 4 | Hanon4 |
| 125 | Hanon Piano Fingering 5 | Hanon5 |

| No. | English Name | LCD Display |
|-----|---|-------------|
| 126 | Basic Tutorial Beyer Piano 12 | Beyer12 |
| 127 | Basic Tutorial Beyer Piano 13 | Beyer13 |
| 128 | Basic Tutorial Beyer Piano 14 | Beyer14 |
| 129 | Basic Tutorial Beyer Piano 15 | Beyer15 |
| 130 | Basic Tutorial Beyer Piano 18 | Beyer18 |
| 131 | Cuckoo | Cuckoo |
| 132 | Basic Tutorial Beyer Piano 21 | Beyer21 |
| 133 | Basic Tutorial Beyer Piano 29 | Beyer29 |
| 134 | Butterfly | Buterfly |
| 135 | Basic Tutorial Beyer Piano 45 | Beyer45 |
| 136 | Christmas Eve | XmasEve |
| 137 | Basic Tutorial Beyer Piano 50 | Beyer50 |
| 138 | Basic Tutorial Beyer Piano 52 | Beyer52 |
| 139 | Basic Tutorial Beyer Piano 55 | Beyer55 |
| 140 | Basic Tutorial Beyer Piano 59 | Beyer59 |
| 141 | Beyer Eight Degrees Jump Etude | BeyrJump |
| 142 | Basic Tutorial Beyer Piano The Scale Of C Major | BeyerC |
| 143 | Basic Tutorial Beyer Piano 65 | Beyer65 |
| 144 | Basic Tutorial Beyer Piano 66 | Beyer66 |
| 145 | Old Folks At Home (Piano) | OldFolk2 |
| 146 | Basic Tutorial Beyer Piano The Scale Of G Major | BeyerG |
| 147 | Basic Tutorial Beyer Piano 70 | Beyer70 |
| 148 | Basic Tutorial Beyer Piano 72 | Beyer72 |
| 149 | Basic Tutorial Beyer Piano 73 | Beyer73 |
| 150 | Basic Tutorial Beyer Piano 74 | Beyer74 |

Demo List

| No. | English Name | LCD Display |
|-----|--------------|-------------|
| 1 | Demo | Demo |
| 2 | Bossa Nova | BosaNova |
| 3 | Fusion | Fusion |
| 4 | Jazz | Jazz |
| 5 | Funk | Funk |

Album List

| No. | English Name | LCD Display |
|-----|-------------------------------|-------------|
| 1 | 13 Jours en france | 13France |
| 2 | A lover's concerto | Concerto |
| 3 | A time for us | Timeus |
| 4 | A whiter shade of pale | WhtShade |
| 5 | Adios | Adios |
| 6 | After you've gone | U'veGone |
| 7 | Again | Again |
| 8 | Agua de beber | AguaBebr |
| 9 | Air for the G-string | G-String |
| 10 | All alone am I | AloneAml |
| 11 | All his children | Children |
| 12 | All shook up | ShookUp |
| 13 | Aloha oe | AlohaOe |
| 14 | Always in my heart | MyHeart |
| 15 | Amapola | Amapola |
| 16 | Amazing grace | AmzGrace |
| 17 | Amor | Amor |
| 18 | An der shonen blauen donau | Donau |
| 19 | Anastasia | Anastasi |
| 20 | Angel | Angel |
| 21 | Angustia | Angustia |
| 22 | Annie laurie | AnnieLa |
| 23 | Are you lonesome tonight? | Lonesome |
| 24 | Arirang | Arirang |
| 25 | Around the world | AroWorld |
| 26 | Auf flugeln des gesanges | Gesanges |
| 27 | Auld lang syne | LangSyne |
| 28 | Ave maria | AveMaria |
| 29 | Bad moon rising | BadMoon |
| 30 | Battle hymne of the republic | BatlHyme |
| 31 | Beautiful dreamer | Dreamer |
| 32 | Besame mucho | Besame |
| 33 | Beyond the reef | BeyndRef |
| 34 | Bibbidi bobbidi boo | Bibbidi |
| 35 | Bittersweet samba | Bitsweet |
| 36 | Blue christmas | BlueXmas |
| 37 | Blue tango | BluTango |
| 38 | Blueberry hill | Blueberry |
| 39 | Born free | BornFree |
| 40 | Brazil | Brazil |
| 41 | Breaking up is hard to do | BreakUp |
| 42 | Bridal march | Bridal |
| 43 | Bridge over troubled water | Bridge |
| 44 | Bus stop | BusStop |
| 45 | Buttons and bows | BottnBow |
| 46 | Cachito | Cachito |
| 47 | Canadian sunset | CaSunset |
| 48 | Can't help fallin' in love | InLove |
| 49 | Carry me back to old virginny | Virginny |
| 50 | Chanson D'amour | Chanson |
| 51 | Chanson du toreador | Toreador |
| 52 | Charade | Charade |

| No. | English Name | LCD Display |
|-----|----------------------------------|-------------|
| 53 | Chattanooga shoe shine boy | ShoeBoy |
| 54 | Clelito lindo | CleLindo |
| 55 | Close to you | CloseYou |
| 56 | Constantly | Constant |
| 57 | Cryin' in the chapel | CryChapl |
| 58 | Dance des mirlitons | Mirliton |
| 59 | Danny boy | DannyBoy |
| 60 | Dark eyes | DarkEyes |
| 61 | Diana | Diana |
| 62 | Die lorelei | Lorelei |
| 63 | Do re mi | DoReMi |
| 64 | Dominique | Dominiqu |
| 65 | Dream | Dream |
| 66 | Dream tango | DremTngo |
| 67 | Ebb tide | EbbTide |
| 68 | Edelweiss | Edelweis |
| 69 | El bimbo | ElBimbo |
| 70 | El condor pasa | ElCondor |
| 71 | Eso es el amor | EsAmor |
| 72 | Esperanza | Esperanz |
| 73 | Etude op.10 no.3 | Etude3 |
| 74 | Fascination | Fascina |
| 75 | Feelings | Feelings |
| 76 | Five hundred miles | 500Miles |
| 77 | Five minutes more | FiveMore |
| 78 | Fly me to the moon | FlyMoon |
| 79 | For ever we konw | WeKnow |
| 80 | For the good times | GoodTime |
| 81 | Frohlicher landmann | Landmann |
| 82 | Fruhlingsstimmen | Fruhling |
| 83 | Gavotte | Gavotte |
| 84 | Green fields | Fields |
| 85 | Green, green grass of home | GreenGrs |
| 86 | Greensleeves | Sleeves |
| 87 | Gwine to run all night | Gwine |
| 88 | Gypsy moon | GypsMoom |
| 89 | Happy birthday to you | Birthday |
| 90 | Harbour light | Harbour |
| 91 | Harlem nocturne | Harlem |
| 92 | Hasta manana | HasMana |
| 93 | Heidenroslein | Heidenro |
| 94 | Her bright smile haunts me still | HerSmile |
| 95 | Hernando's hideaway | Hideaway |
| 96 | Hey jude | HeyJude |
| 97 | Historia de un amor | Historia |
| 98 | Home on the range | HomeRnge |
| 99 | Home sweet home | SwetHome |
| 100 | Hound dog | HoundDog |
| 101 | How deep is your love | DeepLove |
| 102 | Hungarian dances no.5 | Hungaian |
| 103 | Hurry sundown | Sundown |
| 104 | Hymne a l'amour | L'amour |

Album List

| No. | English Name | LCD Display |
|-----|------------------------------------|-------------|
| 105 | I don't hurt any more | HurtMore |
| 106 | I kiss your little hand, madame | kissyour |
| 107 | I love you much too much | LoveYou |
| 108 | I need you now | INeedYou |
| 109 | I really don't want to know | DontKnow |
| 110 | I went to your wedding | UrWeding |
| 111 | If | If |
| 112 | If I can dream | IfDream |
| 113 | If I give my heart to you | HeartYou |
| 114 | In the mood | InMood |
| 115 | It's almost tomorrow | Tomorrow |
| 116 | It's been a long, long time | LongTime |
| 117 | Jambalaya | Jambalay |
| 118 | Jazz'n' samba | JazSamba |
| 119 | Jeanie with the light brown hair | Jeanie |
| 120 | Jingle bells | JingBell |
| 121 | Johnny B. Goode | B.Goode |
| 122 | Joy to the world | JoyWorld |
| 123 | Jungle drums | JungleDm |
| 124 | Kaiser walzer | Kaiser |
| 125 | Keep searchin' | Searchin |
| 126 | Killing me softly with his song | HisSong |
| 127 | Kiss | Kiss |
| 128 | Kiss of fire | KissFire |
| 129 | La chanson D'orpee | D'Orpee |
| 130 | La contessa scalza | Scalza |
| 131 | La cucaracha | Cucarach |
| 132 | La donne mobile | DoneMble |
| 133 | La mer | LaMer |
| 134 | La novia | LaNovia |
| 135 | La paloma | LaPaloma |
| 136 | La playa | LaPlaya |
| 137 | La ragazza di bube | Bube |
| 138 | La reine de saba | Saba |
| 139 | L'amour est blue | L'amour |
| 140 | Lara's theme from "Doctor zhivago" | Zhivago |
| 141 | Last waltz | LastWltz |
| 142 | Les feuilles mortes | Feuilles |
| 143 | Let's get together | Together |
| 144 | Little brown jug | BrownJug |
| 145 | Long, long ago | LongAgo |
| 146 | Love is a many-splendored thing | SplndLov |
| 147 | Love me with all your heart | AllHeart |
| 148 | Love story | LovStory |
| 149 | Lullaby of birdland | Birdland |
| 150 | Mama inez | Mamalnez |
| 151 | Mambo No. 5 | MamboNo5 |
| 152 | Mambo No. 8 | MamboNo8 |
| 153 | March militaire | Militair |
| 154 | Maria elena | MriaElna |
| 155 | Maria, my own | Maria |
| 156 | Massachusetts | Maschuse |

| No. | English Name | LCD Display |
|-----|-------------------------------------|-------------|
| 157 | Menuet | Menuet |
| 158 | Miami beach rumba | MamiRmba |
| 159 | Misty | Misty |
| 160 | Mockin'bird hill | BirdHill |
| 161 | Moliendo Coffee | Coffee |
| 162 | Moody river | ModyRivr |
| 163 | Moon river | MoonRivr |
| 164 | Moonlight serenade | Moonligt |
| 165 | More | More |
| 166 | Moscow nights | Moscow |
| 167 | Moulin rouge | MoulinRg |
| 168 | Mr.lonely | MrLonely |
| 169 | My bonnie | MyBonnie |
| 170 | My darling clementine | Clementine |
| 171 | My old kentucky home | Kentucky |
| 172 | My shawl | MyShawl |
| 173 | My way | MyWay |
| 174 | Nature boy | NaturBoy |
| 175 | Never on sunday | NeverSun |
| 176 | New world | NewWorld |
| 177 | Night fall | NigtFall |
| 178 | Nobody knows the trouble I've seen | Nobody |
| 179 | Noche de tokyo | Tokyo |
| 180 | Nocturne | Nocturne |
| 181 | O sole mio | OSoleMio |
| 182 | Oh! Carol | Oh!Carol |
| 183 | Oh! Susanna | Susanna |
| 184 | Oh, bury me not on the lone prairie | Prairie |
| 185 | Oh, what a beautiful morning | OMorning |
| 186 | Old black joe | BlackJoe |
| 187 | Old dog tray | DogTray |
| 188 | Old folks at home | OldFolks |
| 189 | On a little bamboo bridge | BambooBg |
| 190 | On a tropic night | TrpicNgt |
| 191 | On london bridge | OnBridge |
| 192 | On the beach at bali-bali | BaliBali |
| 193 | One way ticket to the blues | OWTickets |
| 194 | Only you | OnlyYou |
| 195 | Over the rainbow | Rainbow |
| 196 | Over the waves | OverWave |
| 197 | Par un beau matin d'ete | BeauMatn |
| 198 | Patricia | Patricia |
| 199 | Penelope | Penelope |
| 200 | Perfidia | Perfidia |
| 201 | Petite fleur | Fleur |
| 202 | Piacer d'amor | Piacer |
| 203 | Pizzicato polka | PizzPoka |
| 204 | Pretend | Pretend |
| 205 | Proud mary | ProdMary |
| 206 | Quien sera | QuieSera |
| 207 | Quizas, Quizas, Quizas | Quizas |
| 208 | Raindrops keep fallin' on my head | Raindrop |

| No. | English Name | LCD Display |
|-----|------------------------------------|-------------|
| 209 | Ramona | Ramona |
| 210 | Red river valley | RedRiver |
| 211 | Rhythm of the rain | RhymRain |
| 212 | Rock around the clock | Rock |
| 213 | Romance de l'amour | Romance |
| 214 | Royal garden blues | RoyalBlu |
| 215 | Sail along silv'ry moon | SilyMoon |
| 216 | Sailing | Sailing |
| 217 | San Francisco | Francico |
| 218 | Sans toi mamie | ToiMami |
| 219 | Santa claus is comin' to town | SantClau |
| 220 | Santa lucia | SantaLuc |
| 221 | Scarborough fair | Scarboro |
| 222 | Sealed with a kiss | Sealed |
| 223 | Sentimental journey | Journey |
| 224 | Serenade | Serenade |
| 225 | Serenata rimpiant | Serenata |
| 226 | Siboney | Siboney |
| 227 | Silent night | SitNight |
| 228 | Singin' in the rain | SingRain |
| 229 | Sleepy Lagoon | Lagoon |
| 230 | Sloop John B | JohnB |
| 231 | Smoke gets in your eyes | SmokeEye |
| 232 | So nice | SoNice |
| 233 | Solamente una ves | Salament |
| 234 | Somebody bad stole de wedding bell | StoleBel |
| 235 | Songs of spring | SngSprig |
| 236 | Speak softly love | SoftLove |
| 237 | ST. Louis blues | ST.Louis |
| 238 | Stranger in paradise | Paradise |
| 239 | Strangers in the night | Stranger |
| 240 | Summer holiday | Holiday |
| 241 | Summertime | Summer |
| 242 | Summertime in venice | Venice |
| 243 | Sunrise, sunset | Sunrise |
| 244 | Superstar | Superstr |
| 245 | Sweet and gentle | SwetGtle |
| 246 | Taboo | Taboo |
| 247 | Take me home, country roads | CntyRoad |
| 248 | Tales of hoffman | Hoffman |
| 249 | Tammy | Tammy |
| 250 | Tango notturno | TangoNot |
| 251 | Tennessee waltz | Tennesse |
| 252 | The blue-bells of scotland | BlueBell |
| 253 | The breeze and I | Breeze&I |
| 254 | The dying swan | DyingSwm |
| 255 | The end of the world | EndWorld |
| 256 | The exodus song | Exodus |
| 257 | The eyes of love | EyesLove |
| 258 | The girl from ipanema | Ipanema |
| 259 | The great pretender | Pretend |
| 260 | The house of the rising sun | RiseSun |

| No. | English Name | LCD Display |
|-----|--|-------------|
| 261 | The impossible dream | ImDream |
| 262 | The loco-motion | TheLoco |
| 263 | The longest day | Longest |
| 264 | The peanut vendor | Vendor |
| 265 | The river of no return | NoReturn |
| 266 | The shadow of your smile | UrSmile |
| 267 | The skaters waltz | Skaters |
| 268 | The sound of silence | Silence |
| 269 | The wabash cannon ball | CannBall |
| 270 | The way we were | TheWay |
| 271 | This land is your land | YourLand |
| 272 | Those were the days | TheDays |
| 273 | Three coins in the fountain | Fountain |
| 274 | Tico-tico | TicoTico |
| 275 | Tie a yellow ribbon'round the ole oak tree | YeRibbon |
| 276 | To love again | LovAgain |
| 277 | Toccata | Toccata |
| 278 | Tom dooley | TomDoley |
| 279 | Tombe la neige | LaNeige |
| 280 | Top of the world | TopWorld |
| 281 | Toy symphony | ToySymph |
| 282 | Traumerei | Traumere |
| 283 | Triumphal march | Trimphal |
| 284 | Tu ne sais pas aimer | TuAimer |
| 285 | Turkey in the straw | TukyStaw |
| 286 | Un buco nella sabbia | Sabbia |
| 287 | Una lacrima sul viso | Lacrima |
| 288 | Unchained melody | Melody |
| 289 | Valse des fleurs | Fleurs |
| 290 | Vaya con dios | VayaDios |
| 291 | Venus | Venus |
| 292 | Washington square | Washnton |
| 293 | Waves of the danube | Danube |
| 294 | Wedding march | Wedding |
| 295 | When you and I were young, maggie | YoungMag |
| 296 | Where the boys are | WhereBoy |
| 297 | Whispering hope | Whisper |
| 298 | Wiegenlied | Wieglied |
| 299 | Wiegenlied 2 | Wieglied2 |
| 300 | Without you | WithoutU |
| 301 | Wonderland by night | WonNight |
| 302 | Words | Words |
| 303 | Y.M.C.A. | Y.M.C.A. |
| 304 | Yellow rose of texas | YellRose |
| 305 | Yesterday | Yestday |
| 306 | Yesterday once more | OnceMore |
| 307 | You always hurt the one you love | HurtLove |
| 308 | You are my sunshine | Sunshine |
| 309 | You mean everything to me | MeanToMe |
| 310 | Your love is mine | LoveMine |

Chord List

| Chord Name (Abbreviation) | Normal Voicing | Chord | Display |
|--------------------------------------|------------------------------------|--------|---------|
| Major [M] | 1-3-5 | C | C |
| Major sixth [6] | 1-(3)-5-6 | C6 | C6 |
| Major seventh [M7] | 1-3-(5)-7 | CM7 | CM7 |
| Major seventh sharp eleventh [M7#11] | 1-(2)-3-#4-(5)-7 | CM7#11 | CM7#11 |
| Major add ninth [Madd9] | 1-2-3-5 | Cmadd9 | CM(9) |
| Major ninth [M9] | 1-2-3-(5)-7 | CM9 | CM7(9) |
| Major sixth add ninth [6 9] | 1-2-3-(5)-6 | C6 9 | C6(9) |
| Augmented [aug] | 1-3-#5 | Caug | Caug |
| Minor [m] | 1-b3-5 | Cm | Cm |
| Minor sixth [m6] | 1-b3-5-6 | Cm6 | Cm6 |
| Minor seventh [m7] | 1-b3-(5)-b7 | Cm7 | Cm7 |
| Minor seventh flatted fifth [m7b5] | 1-b3-b5-b7 | Cm7b5 | Cm7b5 |
| Minor add ninth [madd9] | 1-2-b3-5 | Cmadd9 | Cm(9) |
| Minor ninth [m9] | 1-2-b3-(5)-b7 | Cm9 | Cm7(9) |
| Minor eleventh [m11] | 1-(2)-b3-4-5-(b7) | Cm11 | Cm7(11) |
| Minor major ninth [mM7] | 1-b3-(5)-7 | CmM7 | CmM7 |
| Minor major ninth [mM9] | 1-2-b3-(5)-7 | CmM9 | CmM7(9) |
| Diminished [dim] | 1-b3-b5 | Cdim | Cdim |
| Diminished seventh [dim7] | 1-b3-b5-6 | Cdim7 | Cdim7 |
| Seventh [7] | 1-3-(5)-b7 | C7 | C7 |
| Seventh suspended fourth [7sus4] | 1-4-5-b7 | C7sus4 | C7sus4 |
| Seventh flatted fifth [7b5] | 1-3-b5-b7 | C7b5 | C7b5 |
| Seventh ninth [7 9] | 1-2-3-(5)-b7 | C7 9 | C7(9) |
| Seventh sharp eleventh [7#11] | 1-2-3-#4-(5)-b7 or 1-(2)-3-#4-5-b7 | C7#11 | C7(#11) |
| Seventh thirteenth [7 13] | 1- 3-(5)-6-b7 or 2- 3-5-6-b7 | C7 13 | C7(13) |
| Seventh flatted ninth [7b9] | 1-b2-3-(5)-b7 | C7b9 | C7(b9) |
| Seventh flatted thirteenth [7b13] | 1-3-5-b6-b7 | C7b13 | C7(b13) |
| Seventh sharp ninth [7#9] | (1)-#2-3-(5)-b7 | C7#9 | C7(#9) |
| Major seventh augmented [M7aug] | 1-3-#5-7 | CM7aug | CM7aug |
| Seventh augmented [7aug] | (1)-3-#5-b7 | C7aug | C7aug |
| Suspended fourth [sus4] | 1-4-5 | Csus4 | Csus4 |
| One plus two plus five [1+2+5] | 1-2-5 | C1+2+5 | C |

MIDI Implementation Chart

| Function | | Transmitted | Recognized | Remarks |
|--|---------------|---------------|-------------------------|-----------------------|
| Basic Channel | Default | 1ch | 1-16ch | |
| | Changed | 1-16ch | 1-16ch | |
| Mode | Default | x | 3 | |
| | Messages | x | x | |
| | Altered | ***** | x | |
| Note Number | Note | 0—127 | 0—127 | |
| | :True voice | ***** | 0—127 | |
| Velocity | Note on | o 9nH,V=1-127 | o 9nH,V=1-127 | |
| | Note off | x (9nH,V=0) | o(9nH,V=0; 8nH,V=0-127) | |
| After Touch | key's | x | x | |
| | Ch's | x | x | |
| Pitch Bend | | x | o | |
| Control Change | 0 | o | o | Bank Select |
| | 1 | o | o | Modulation |
| | 5 | x | o | Portamento Time |
| | 6 | o | o | Data Entry |
| | 7 | o | o | Volume |
| | 10 | x | o | Pan |
| | 11 | x | o | Expression |
| | 64 | o | o | Sustain Pedal |
| | 65 | x | o | Portamento ON/OFF |
| | 66 | o | o | Sostenuto Pedal |
| | 67 | o | o | Soft Pedal |
| | 80 | x | o | Reverb Program |
| | 81 | x | o | Chorus Program |
| | 91 | o | o | Reverb Level |
| | 93 | o | o | Chorus Level |
| | 120 | o | o | All Sound Off |
| | 121 | x | x | Reset All Controllers |
| 123 | o | o | All Notes Off | |
| Program Change | :true | ***** | 0—127 | |
| System Exclusive | | x | o | |
| System Common | :SongPosition | x | x | |
| | :Song Select | x | x | |
| | :Tune | x | x | |
| System Real Time | :Clock | o | x | |
| | :Commands | x *1 | x | |
| Aux Messages | :LOCAL ON/OFF | x | x | |
| | :Active sense | x | o | |
| | :Reset | x | x | |
| Notes: *1 When the accompaniment is started, an FAH message is transmitted. When accompaniment is stopped, an FCH message is transmitted. | | | | |

- Mode 1: OMNI ON, POLY
- Mode 2: OMNI ON, MONO

- Mode 3: OMNI OFF, POLY
- Mode 4: OMNI OFF, MONO

- x: NO
- o: YES



We love music!

WEEE-Declaration

Your product is designed and manufactured with materials and components of high quality, which are recyclable and can be reused.

The symbol means that your product should be disposed of separately from household waste when it reaches its end of life.

Please dispose of this equipment at your local collection point or recycling center.

Please help to protect the environment in which we all live.

Intellectual property /Copyright

All specifications and appearances are subject to change without notice.

All information was correct at time of printing. Musikhaus Kirstein GmbH does not guarantee for the accuracy or completeness of any description, photograph or statement contained in this manual.

Printed colours and specifications may vary slightly from product. Products from Musikhaus Kirstein GmbH products are only sold through authorized dealers. Distributors and dealers are not agents of

Musikhaus Kirstein GmbH and have no authority to bind Musikhaus Kirstein GmbH legally in any way.

This manual is protected by copyright. Any copying or reprint, even in excerpts, is only allowed with written consent of Musikhaus Kirstein GmbH.

The same applies to reproduction or copying of images, even in altered form.



Musikhaus Kirstein GmbH
Bernbeurener-Str.11
D-86956 Schongau
Tel.0049-8861-909494-0
Fax:0049-8861-909494-19
www.kirstein.de