



Professional Power Amplifier Owner's Manual



XA Series

Professional Power Amplifier

Before attempting to connect, operate or adjust this product, please read these instructions completely
pr-xa-series_EN_2024

XA Series

PROFESSIONAL POWER AMPLIFIER



Congratulations for choosing **PRONOMIC XA** Series professional power amplifier. You purchased one of the finest stereo amplifiers on the market today. This unit was developed using the expertise of professional sound engineers and working musicians. You will find that your new **PRONOMIC XA** Series amplifier has superior performance and greater flexibility than any other amplifiers in its price range. Please read this manual carefully to get the most out of your new unit.

FEATURES

Offering top power, superior performance and full professional operating features in a roadworthy compact chassis, the **XA** Series are perfect for even the most demanding sound reinforcement installation and touring applications.

The operating amplifier instruction in this manual are for all the **XA** Series professional power amplifiers. The operation and functions of these units are the same, except as noted.

- . Full operating features: detent volume controls; parallel balanced XLR and 1/4" TRS inputs; stereo (dual channel), parallel-input, or bridged mono operating modes with selector switch; Independent user defeatable clip limiters (compressor) 3 selectable input sensitivities, ground lift switch, binding post (banana plug) and speakon outputs.
- . Full safety/re liability features: 2 dual speed fans for cooling; soft start turn on, noise-free on-off; independent DC and thermal overload protection on each channel; short circuit and speaker protection; built-in current limiter.
- . Front panel led indicators: Power, Signal, IPC and protection
- . Roadworthy, rugged double rack space (2U/3U) housing Series
- . ~230V(50Hz) AC select switch and IEC cord power

Table of contents

FEATURES	3
WARNING	4
INSTALLATION.....	4
FRONT & REAR PANEL CONNECTIONS (2U).....	5
CONNECTIONS (2U).....	7
FRONT & REAR PANEL CONNECTIONS (3U).....	9
CONNECTIONS (3U).....	11
BLOCK DIAGRAM	13
SPECIFICATIONS	14

For your records

Date of Purchase _____

Dealer's Name _____

City _____

State _____ Zip _____

Model # _____

Serial # _____

WARNING



An equilateral triangle enclosing a lightning flash/arrowhead symbol is intended to alert the user to the presence of uninsulated "dangerous voltage" within the product's enclosure which may be of sufficient magnitude to constitute a risk of electric shock.



An equilateral triangle enclosing an exclamation point is intended to alert the user to the presence of important operating and service instructions in the literature enclosed with this unit.

IMPORTANT SAFETY INSTRUCTIONS

When using this electronic device, basic precautions should always be taken, including the following:

1. Read all instructions before using the product.
2. Do not use this product near water (e.g., near a bathtub, washbowl, kitchen sink, in a wet basement, or near a swimming pool, etc.).
3. This product should be used only with a cart or stand that will keep it level and stable and prevent wobbling.
4. This product, in combination with headphones or speakers, may be capable of producing sound levels that could cause permanent hearing loss. Do not operate for a long period of time at a high volume level or at a level that is uncomfortable. If you experience any hearing loss or ringing in the ears, you should consult an audiologist.
5. The product should be positioned so that proper ventilation is maintained.
6. The product should be located away from heat sources such as radiators, heat vents, or other devices (including amplifiers) that produce heat.
7. The product should be connected to a power supply only of the type described in the operating instructions or as marked on the product. Replace the fuse only with one of the specified type, size, and correct rating.
8. The power supply cord should: (1) be undamaged, (2) never share an outlet or extension cord with other devices so that the outlet's or extension cord's power rating is exceeded, and (3) never be left plugged into the outlet when not being used for a long period of time.
9. Care should be taken so that objects do not fall into, and liquids are not spilled through, the enclosure's openings.
10. The product should be serviced by qualified service personnel if:
 - A. The power supply cord or the plug has been damaged.
 - B. Objects have fallen into, or liquid has been spilled onto the product.
 - C. The product has been exposed to rain.
 - D. The product does not appear to operate normally or exhibits a marked change in performance.
 - E. The product has been dropped, or the enclosure damaged.
11. Do not attempt to service the product beyond what is described in the user maintenance instructions. All other servicing should be referred to qualified service personnel.

INSTALLATION

This manual contains important information on operating your **PRONOMIC** amplifier correctly and safely. Please read it carefully before operating your amplifier. If you have any questions, contact your **PRONOMIC** dealer.

UNPACKING

Carefully open the shipping carton and check for any noticeable damage. Every **PRONOMIC XA** Series amplifier is completed tested and inspected before leaving the factory and should arrive in perfect condition. If you find any damage, notify the shipping company immediately. Be sure to save the carton and all packing materials for carrier inspection.

CONTENTS

- . Owner's manual
- . **XA** Series amplifier (verify that the unit's serial number is same as shown on shipping carton)
- . AC Power cord

RACK MOUNTING

The **XA** Series amplifiers are designed for standard 19" rack mounting as well as "stack" mounting without a cabinet. Use 4 screws and washers for mounting to the front rack rails. It is also a good idea to support the amps also in the rear, especially for mobile use where the amps will be subjected to strong vibrations.

AMPLIFIER COOLING

Also pay close attention to the cooling requirements. Never block the air vents in the back side and front of the amplifier. Do not install the amplifier in a location that is exposed to direct rays of the sun, or near hot appliances or radiators. Excessive heat can adversely affect the cabinet and the internal components. Installation of the amplifier in a damp or dust environment may result in malfunction or accident. If installed in a rack please be sure to open completely the back door. Periodically remove the internal dust by using compressed air through the external ventilation holes.

FRONT & REAR CONNECTIONS (2U)

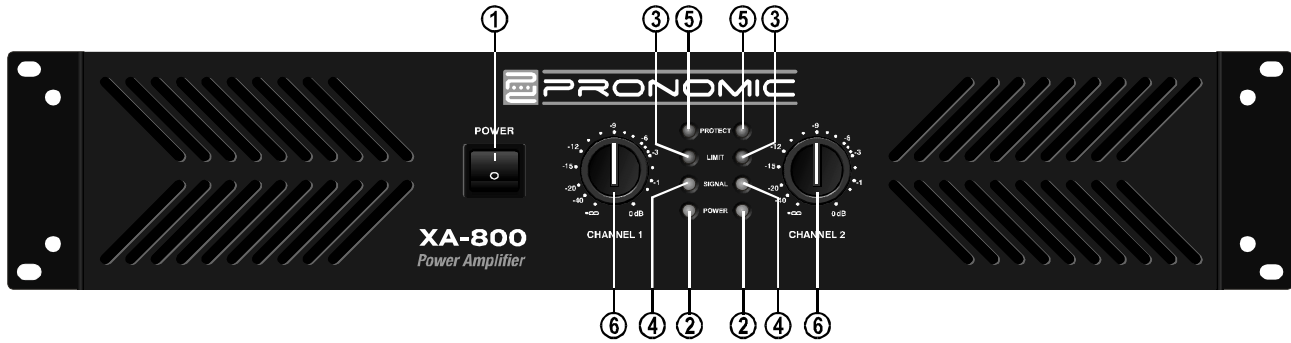

FRONT PANEL

1. POWER SWITCH

To turn the unit ON or OFF, press the upper or lower portion of this button. Before turning on the amplifier, check all connections and turn down the level controls. A momentary muting is normal when turning the amplifier on or off.

(Caution: Always turn on your power amplifier last, after all your other connected equipment, and always turn off your power amplifier before your other connected equipment.)

2. POWER LED INDICATORS

These LEDs illuminate when the power is turned "ON".

3. LIMIT LED INDICATORS

These LEDs illuminate if any section of the power amplifier's output are within 3dB of clipping. Occasional blinking of the LEDs are acceptable, but if they remain on more than intermittently you should turn down either the power amplifier's level controls or reduce the output level of the preceding component to avoid audible distortion.

4. SIGNAL LED INDICATORS

These LEDs illuminate to confirm the presence of an input signal greater than 100 mV at that channel of the amplifier

5. PROTECT LED INDICATORS

These LEDs illuminate if the power amplifier's output connection is shorted, the load impedance is too low. Or if there is an internal malfunction. When either of these LEDs is lit up, turn OFF the power and check the output's connection to verify that it is correct, then turn ON the power again.

6. LEVEL CONTROLS

These control the level of signal coming into each channel. The actual voltage attenuation of the amplifier is shown in dB. Turn these controls counterclockwise if the Limit LEDs illuminate steadily (indicating a too strong input signal).

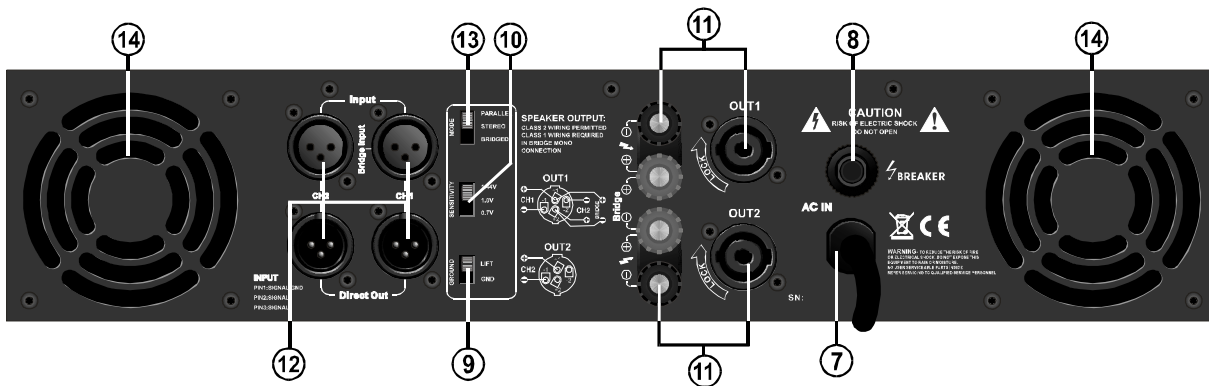

REAR PANEL

7. POWER CONNECTOR

The cord connector is used to connect the AC power source to your power amplifier.

(CAUTION : Always operate the unit with the AC ground wire connected to the electrical system ground)

8. BREAKER

AC circuit breaker. If the breaker continuously blow, shut off the unit and have it serviced by qualified service personnel.

9. GROUND LIFT SWITCH

Switch up to disconnect the chassis from ground if necessary to eliminate hum caused by ground loops.

10. SENSITIVITY SELECTOR SWITCH

The XA Series amplifiers offer 3 SENSITIVITY of operation: 0.7V 1.0V & 1.44V.

11. L/R CHANNEL OUTPUT CONNECTORS

Connections are as described on the rear panel and in the **CONNECTIONS** section on page 7 of this manual.

FRONT & REAR CONNECTIONS (2U)

12. BALANCED INPUT CONNECTORS (XLR)

The XLR connector is compatible with balanced inputs. Since the XLR connector is internally wired in parallel, you can parallel this unit with another amplifier by using the XLR to output the signal to the input connectors of the other amplifier. Balanced connections are recommended as they are less prone to AC hum. For long cable runs a source output impedance of less than 600 ohms is needed to avoid signal loss. For short cable runs an unbalanced signal input should be suitable. For stereo (two-channel) operation, use the inputs for both CH-1 and CH-2; for parallel or bridged mono operation, use only CH-1 input. (See MODE SELECTOR SWITCH below for more explanation.)

13. MODE SELECTOR SWITCH

The **XA** Series amplifiers offer 3 modes of operation: PARALLEL, STEREO & BRIDGED. Slide the switch to one of the three positions for your application.

. **PARALLEL (MONO) INPUT** - This mode allows both channels to operate in parallel with the same signal and without requiring a Y-cord. In this mode the inputs for both channels are

internally connected, so that you only need to feed a signal into one of the channels. This still allows independent level control of each channel. It also enables easy "daisy-chaining" with other amps by using the other channel of input connectors.

(Note: Do not select this "Parallel" mode when feeding the amplifier with 2 separate signals.)

(Note: Do not use both unbalanced and balanced cables in the same set-up as that can unbalance all the connections when daisy-chaining, resulting in hum.)

. **STEREO INPUT** - This is the most common mode generally used, and allows independent control of 2 separate signals such as stereo playback, main and monitor live mixes, and bi-amp operation (highs in one channel and lows in the other).

. **BRIDGED MONO** - This mode combines the power of both channels to drive a single speaker. In this mode the amp produces 4 times the peak power and 3 times the sustained power into a 4 or 8 ohm speaker than each channel can deliver separately in stereo or parallel mode.

(CAUTION: In this mode the amplifier can deliver high power into a speaker. Make sure that the speaker, connectors and wiring can handle this output. Note that for prolonged overdriven outputs into a 4 ohm speaker the mains fuse may blow, so care must be taken not to overload the amplifier in such operation.)

Connect the input signal to CH-1 input for bridged mono operation.

14. VENTILATION HOLES

The fan speed is varied automatically to maintain the proper internal operating temperature.

CONNECTIONS (2U)

The following instructions describe the most common ways to install your amplifier into a sound system.

1. Turn off the amplifier power switch before making any connections.
2. The **XA Series** amplifiers maybe operated in one of three modes (stereo, bridged-mono, and parallel mono). Re fer to the following wiring diagrams for the speaker connections you wish to make.

(Note: **PRONOMIC Systems** assumes no liability for damaged speakers resulting from improper wiring, careless amplifier use, or over powering.)

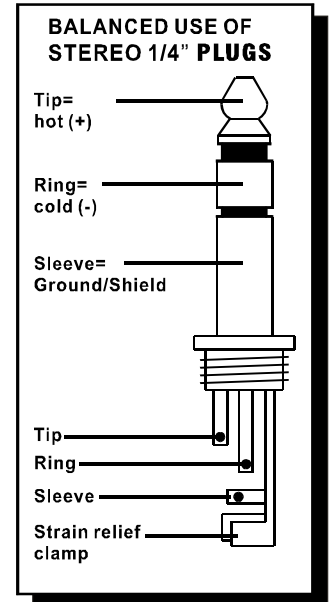
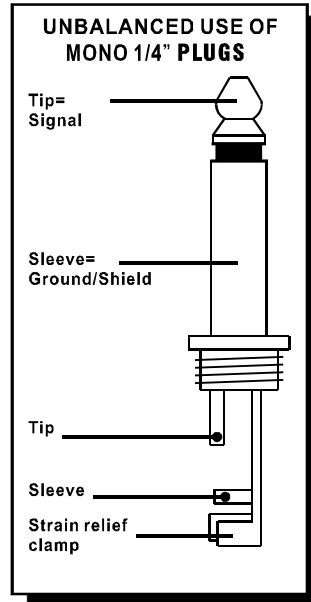
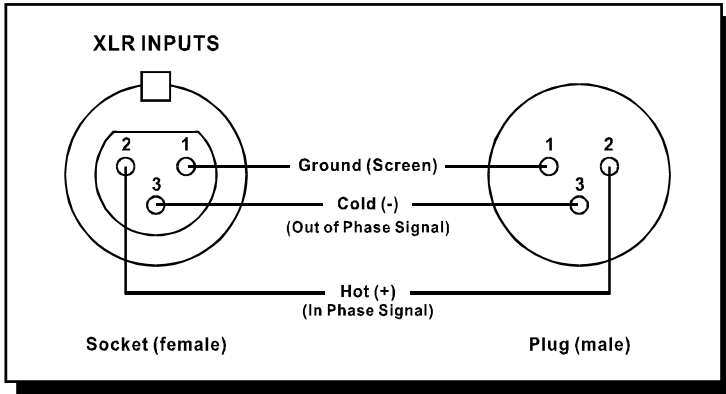

. Stereo (Two-Channel) Mode

To put the amplifier into stereo mode, first turn the amplifier off, then slide the **MODE SELECTOR SWITCH (13)** to the middle "STEREO" position, and properly connect the input/output wiring as shown.

(Note: Do not connect a speaker load less than 4ohms as it can damage your amplifier.)

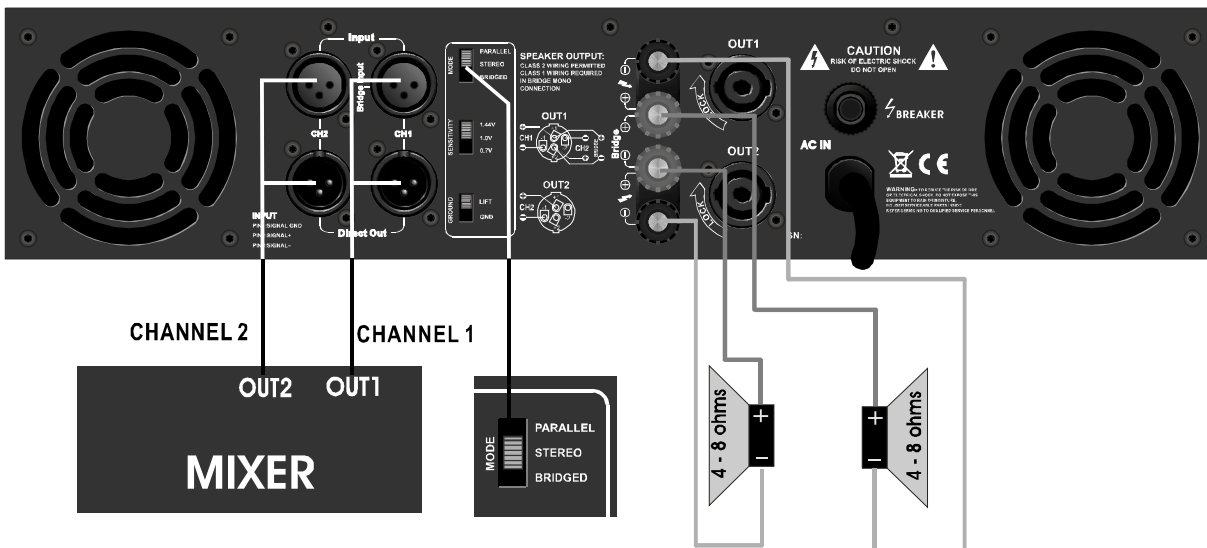

CONNECTIONS (2U)

. Parallel (Mono) Mode

To put the amplifier in parallel-mono mode, first turn the amplifier off, then slide the **MODE SELECTOR SWITCH (13)** to the top "PARALLEL (MONO)" position and properly connect the input/output wiring as shown. A signal into any input connector will drive both channels directly. You can patch the input signal on to any other amps using any of the remaining input jacks.

(Note: Do not connect a speaker load less than 4 ohms as it can damage your amplifier.)

[Note: Do not use the "PARALLEL (MONO)" switch when feeding the amp 2 separate signals.]

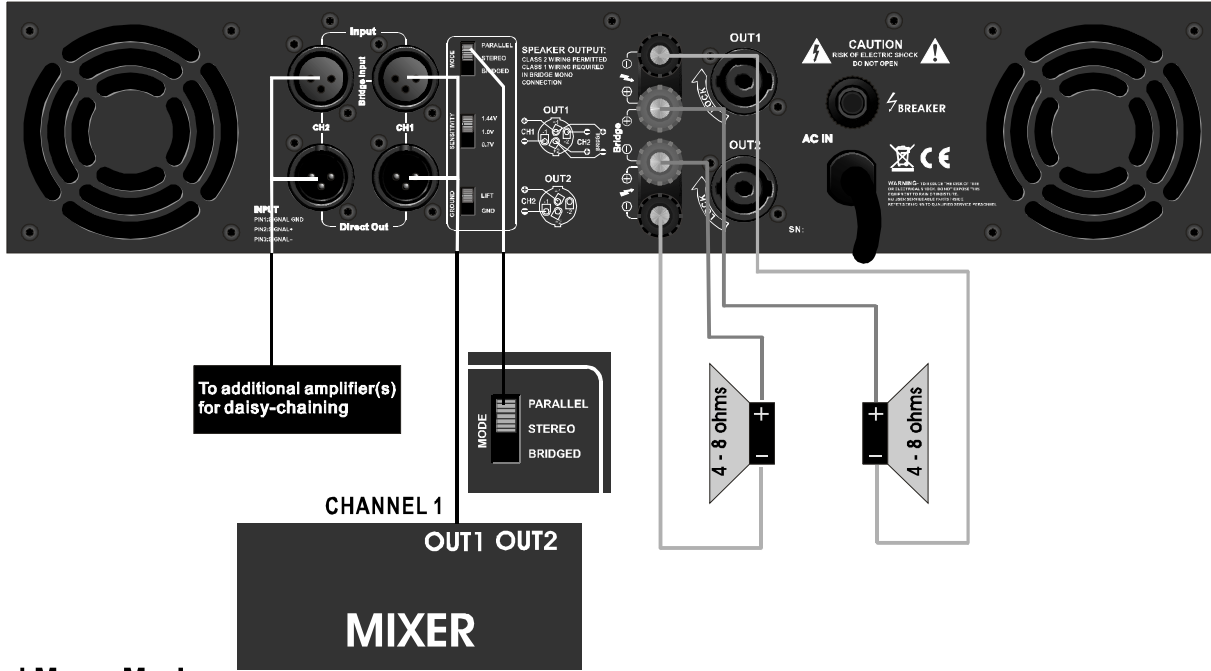

. Bridged Mono Mode

To put the amplifier in bridged mono mode, turn the amplifier off and slide the **MODE SELECTOR SWITCH (13)** toward the bottom "BRIDGED" position and properly connect the input/output wiring as shown. The signal is input from channel 1. Rotate the level control knobs of channel 1 and channel 2 in the same position.

(Note: Do not connect a speaker load of less than 4 ohms as it can damage your amplifier.)

(Note: This mode produces a large amount of power. Be sure that your wiring and speaker can handle it.)

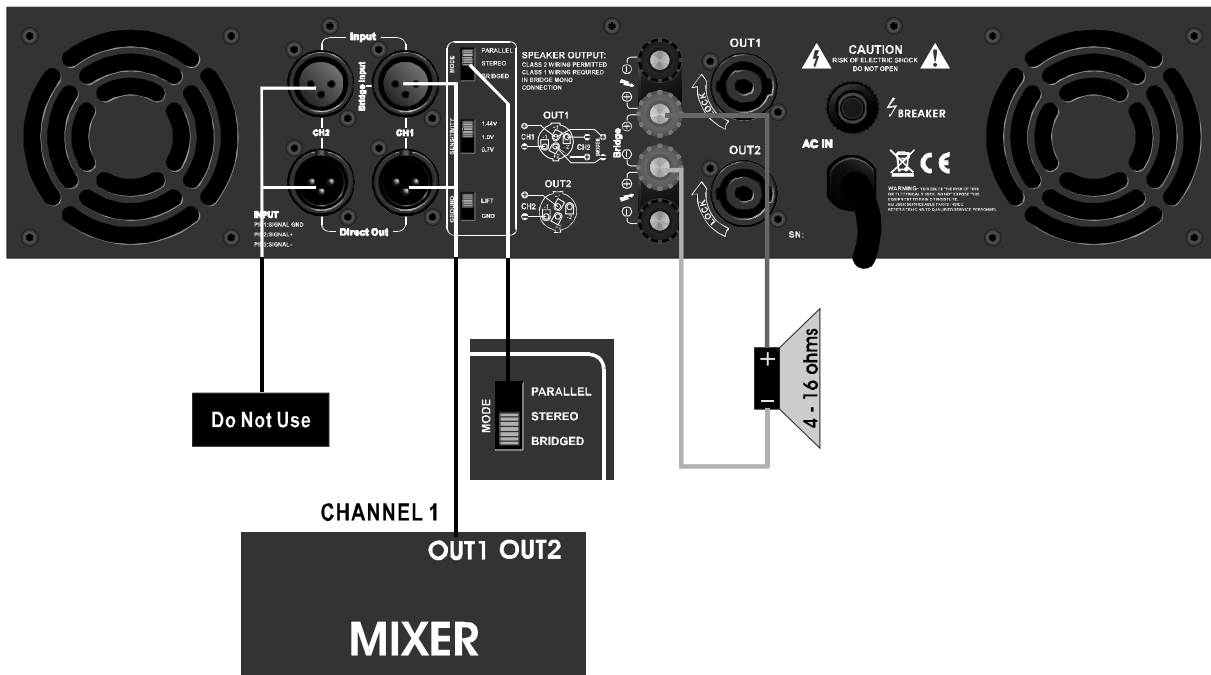

FRONT & REAR CONNECTIONS (3U)

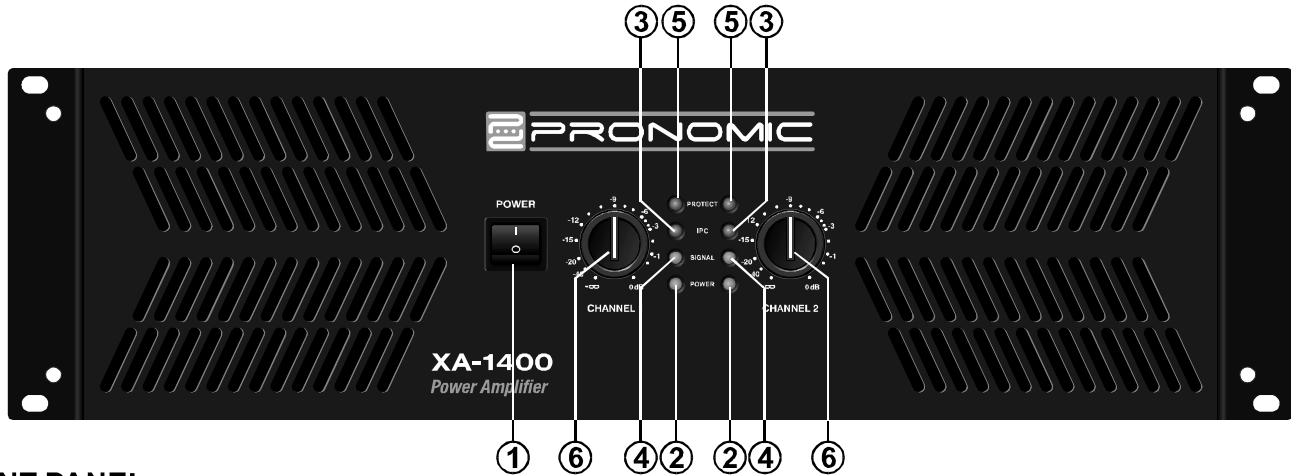

FRONT PANEL

1. POWER SWITCH

To turn the unit ON or OFF, press the upper or lower portion of this button. Before turning on the amplifier, check all connections and turn down the level controls. A momentary muting is normal when turning the amplifier on or off.

(Caution: Always turn on your power amplifier last, after all your other connected equipment, and always turn off your power amplifier before your other connected equipment.)

2. POWER LED INDICATORS

These LEDs illuminate when the power is turned "ON".

3. CLIP LED INDICATORS

These LEDs illuminate if any section of the power amplifier's output are within 3dB of clipping. Occasional blinking of the LEDs are acceptable, but if they remain on more than intermittently you should turn down either the power amplifier's level controls or reduce the output level of the preceding component to avoid audible distortion.

4. SIGNAL LED INDICATORS

These LEDs illuminate to confirm the presence of an input signal greater than 100 mV at that channel of the amplifier

5. PROTECT LED INDICATORS

These LEDs illuminate if the power amplifier's output connection is shorted, the load impedance is too low. Or if there is an internal malfunction. When either of these LEDs is lit up, turn OFF the power and check the output's connection to verify that it is correct, then turn ON the power again.

6. LEVEL CONTROLS

These control the level of signal coming into each channel. The actual voltage attenuation of the amplifier is shown in dB. Turn these controls counterclockwise if the Limit LEDs illuminate steadily (indicating a too strong input signal).

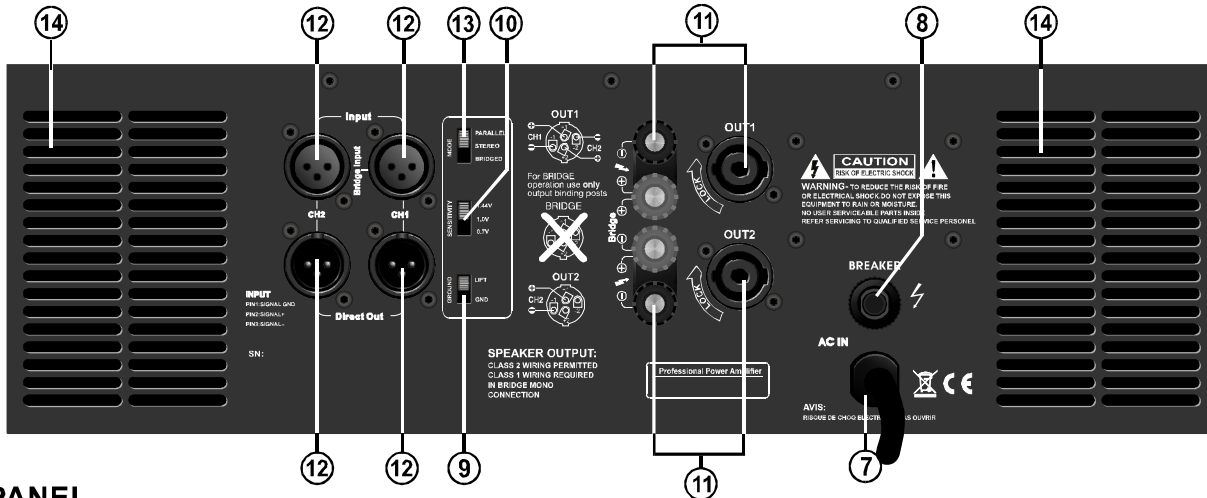

REAR PANEL

7. POWER CONNECTOR

The cord connector is used to connect the AC power source to your power amplifier.

(CAUTION : Always operate the unit with the AC ground wire connected to the electrical system ground)

8. BREAKER

AC circuit breaker. If the breaker continuously blow, shut off the unit and have it serviced by qualified service personnel.

9. GROUND LIFT SWITCH

Switch up to disconnect the chassis from ground if necessary to eliminate hum caused by ground loops.

10. SENSITIVITY SELECTOR SWITCH

The XA Series amplifiers offer 3 SENSITIVITY of operation: 0.7V 1.0V & 1.44V.

11. L/R CHANNEL OUTPUT CONNECTORS

Connections are as described on the rear panel and in the CONNECTIONS section on page 11 of this manual.

FRONT & REAR CONNECTIONS (3U)

12. BALANCED INPUT CONNECTORS (XLR)

The XLR connector is compatible with balanced inputs. Since the XLR connector is internally wired in parallel, you can parallel this unit with another amplifier by using the XLR to output the signal to the input connectors of the other amplifier. Balanced connections are recommended as they are less prone to AC hum. For long cable runs a source output impedance of less than 600 ohms is needed to avoid signal loss. For short cable runs an unbalanced signal input should be suitable. For stereo (two-channel) operation, use the inputs for both CH-1 and CH-2; for parallel or bridged mono operation, use only CH-1 input. (See MODE SELECTOR SWITCH below for more explanation.)

13. MODE SELECTOR SWITCH

The **XA** Series amplifiers offer 3 modes of operation: PARALLEL, STEREO & BRIDGED. Slide the switch to one of the three positions for you application.

. **PARALLEL (MONO) INPUT** - This mode allows both channels to operate in parallel with the same signal and without requiring a Y-cord. In this mode the inputs for both channels are

internally connected, so that you only need to feed a signal into one of the channels. This still allows independent level control of each channel. It also enables easy "daisy-chaining" with other amps by using the other channel of input connectors.

(Note: Do not select this "Parallel" mode when feeding the amplifier with 2 separate signals.)

(Note: Do not use both unbalanced and balanced cables in the same set-up as that can unbalance all the connections when daisy-chaining, resulting in hum.)

. **STEREO INPUT** - This is the most common mode generally used, and allows independent control of 2 separate signals such as stereo playback, main and monitor live mixes, and bi-amp operation (highs in one channel and lows in the other).

. **BRIDGED MONO** - This mode combines the power of both channels to drive a single speaker. In this mode the amp produces 4 times the peak power and 3 times the sustained power into a 4 or 8 ohm speaker than each channel can deliver separately in stereo or parallel mode.

(CAUTION: In this mode the amplifier can deliver high power into a speaker. Make sure that the speaker, connectors and wiring can handle this output. Note that for prolonged overdriven outputs into a 4 ohm speaker the mains fuse may blow, so care must be taken not to overload the amplifier in such operation.)

Connect the input signal to CH-1 input for bridged mono operation.

14. VENTILATION HOLES

The fan speed is varied automatically to maintain the proper internal operating temperature.

CONNECTIONS (3U)

The following instructions describe the most common ways to install your amplifier into a sound system.

1. Turn off the amplifier power switch before making any connections.
2. The **XA Series** amplifiers maybe operated in one of three modes (stereo, bridged-mono, and parallel mono). Re fer to the following wiring diagrams for the speaker connections you wish to make.
(Note: **PRONOMIC Systems** assumes no liability for damaged speakers resulting from improper wiring, careless amplifier use, or over powering.)

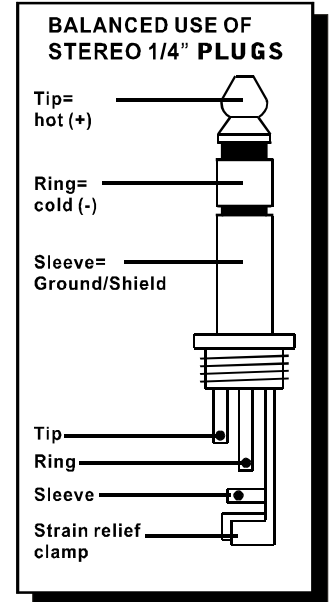
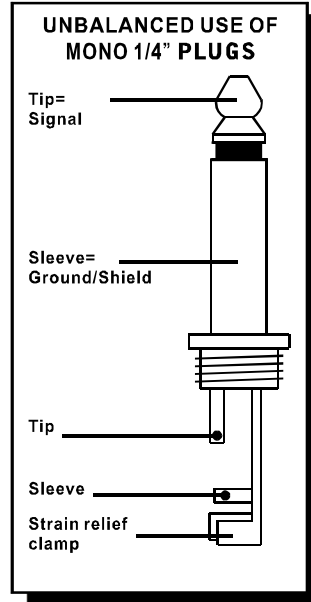
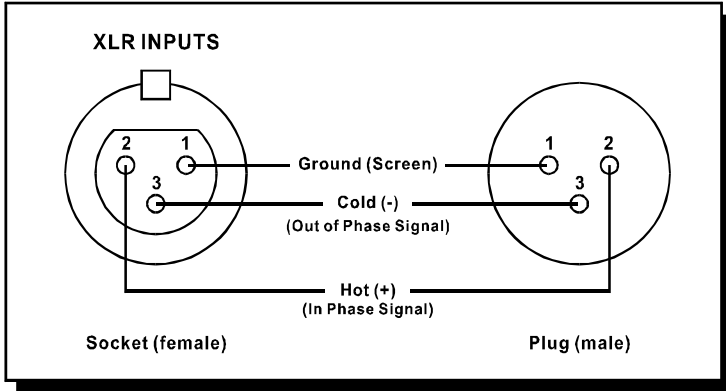

. Stereo (Two-Channel) Mode

To put the amplifier into stereo mode, first turn the amplifier off, then slide the **MODE SELECTOR SWITCH (13)** to the middle "STEREO" position, and properly connect the input/output wiring as shown.

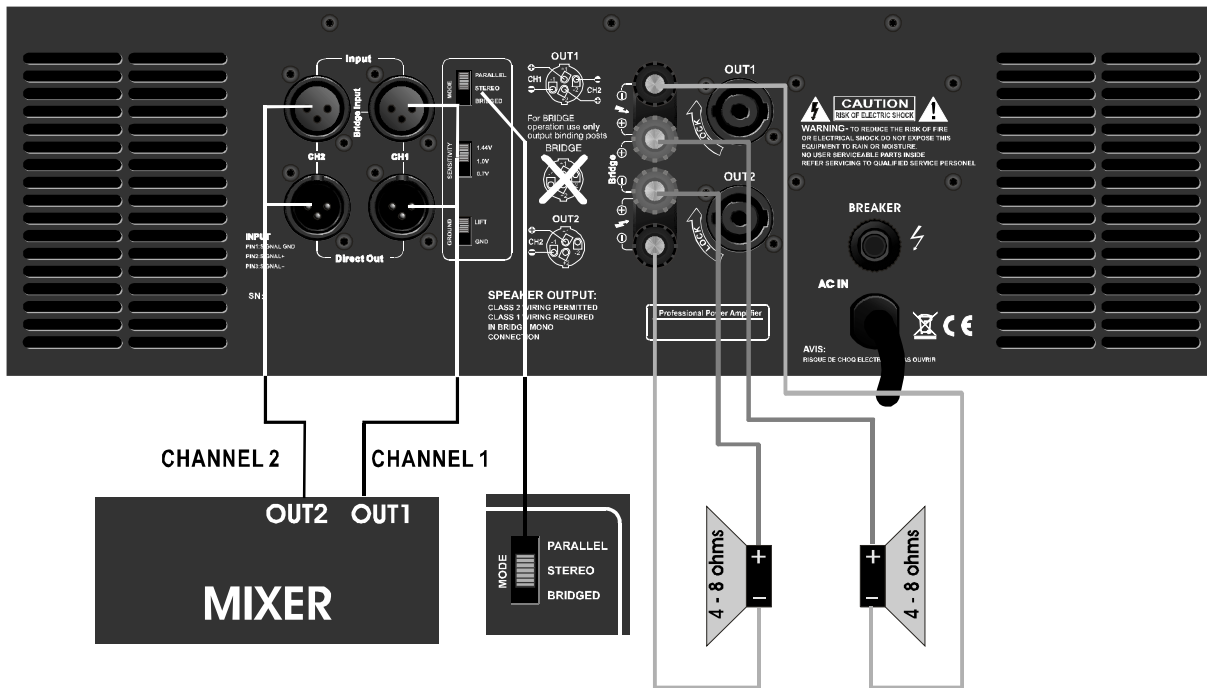

CONNECTIONS (3U)

. Parallel (Mono) Mode

To put the amplifier in parallel-mono mode, first turn the amplifier off, then slide the **MODE SELECTOR SWITCH (13)** to the top "PARALLEL (MONO)" position and properly connect the input/output wiring as shown. A signal into any input connector will drive both channels directly. You can patch the input signal on to any other amps using any of the remaining input jacks.
 [Note: Do not use the "PARALLEL (MONO)" switch when feeding the amp 2 separate signals.]

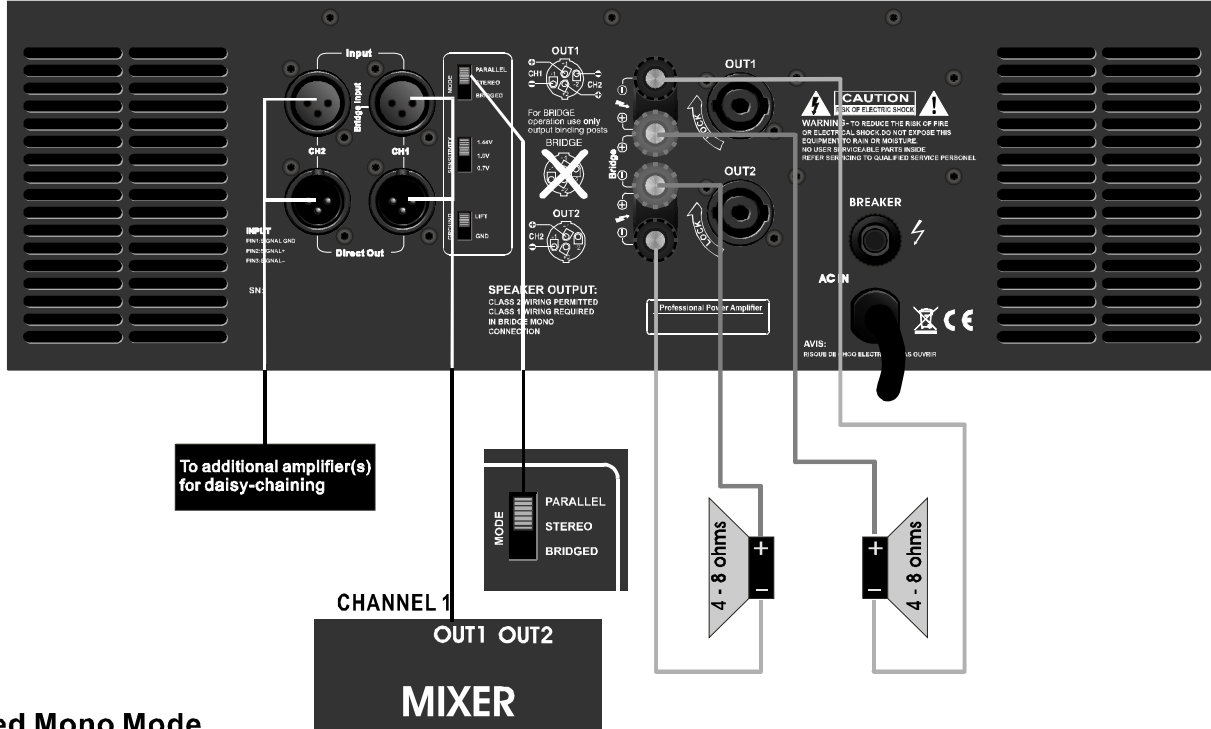

. Bridged Mono Mode

To put the amplifier in bridged mono mode, turn the amplifier off and slide the **MODE SELECTOR SWITCH (13)** toward the bottom "BRIDGED" position and properly connect the input/output wiring as shown. The signal is input from channel 1. Rotate the level control knobs of channel 1 and channel 2 in the same position.
 (Note: Do not connect a speaker load of less than 4 ohms as it can damage your amplifier.)
 (Note: This mode produces a large amount of power. Be sure that your wiring and speaker can handle it.)

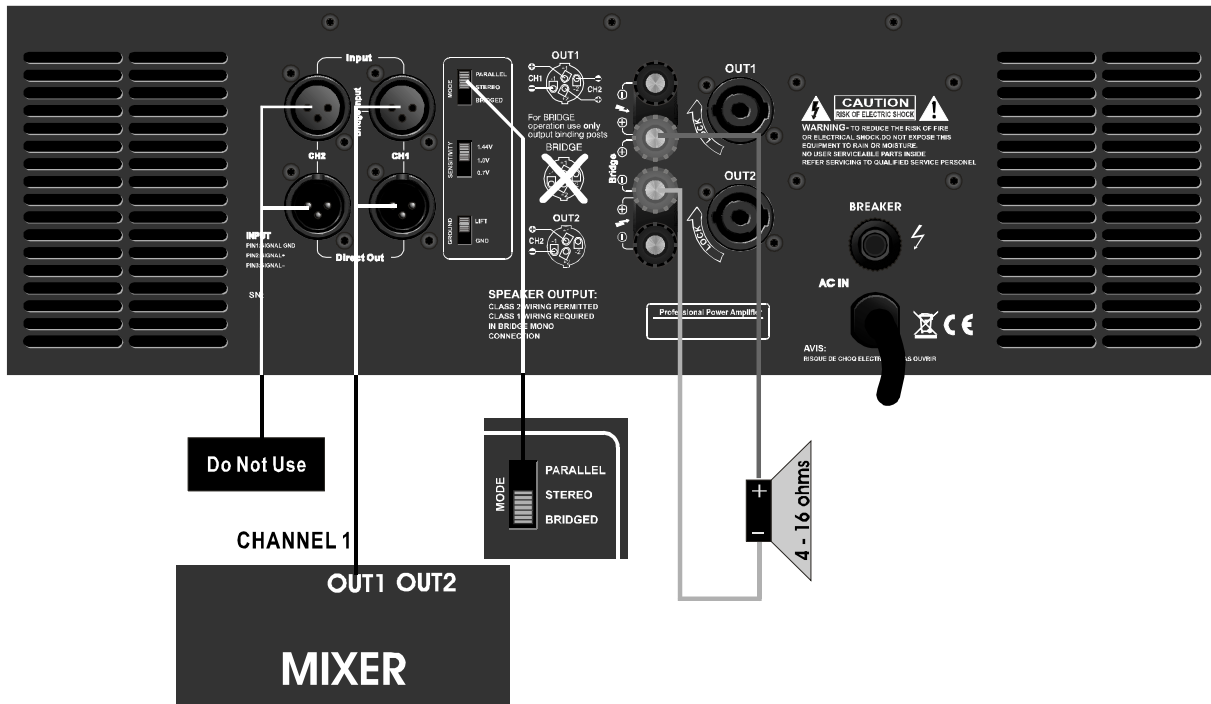

BLOCK DIAGRAM

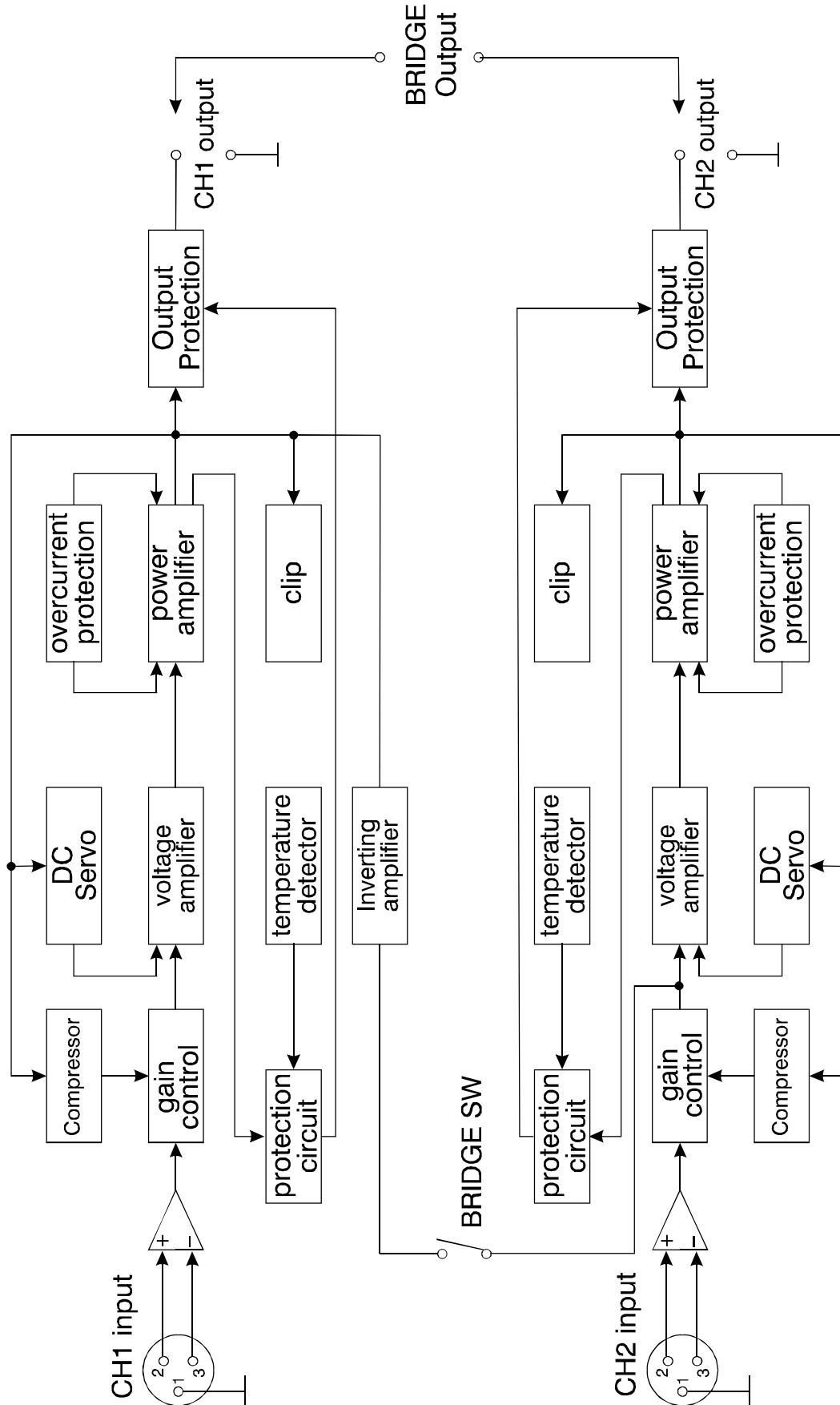

SPECIFICATIONS

MODEL CHARACTERISTIC	XA-400	XA-600	XA-800	XA-1000	XA-1200	XA-1400
Out Power (8Ω)	2x400W	2x600W	2x800W	2x1000W	2x1200W	2x1400W
Out Power (4Ω)	2x650W	2x950W	2x1300W	2x1600W	2x1800W	2x2100W
Out Power (2Ω)	2x950W	2x1400W	2x1900W	2x2400W	2x2700W	2x3000W
Out Power(BRIDGE) (8Ω)	1300W	1900W	2600W	3200W	3600W	4200W
Out Power(BRIDGE) (4Ω)	1900W	2800W	3800W	4800W	5400W	6000W
FREQUENCY RESPONSE @ Half Pwr	15Hz - 25KHz(+0/-1dB)					
THD+Noise @ 1KHz Full Pwr	<0.03%	<0.035%				
IMD 60Hz & 7KHz,4:1	<0.038%	<0.04%				
SIGNAL TO NOISE RATIO	>102dB	>105dB				
SLEW RATE (input filter limited)	40V/μS					
DAMPING FACTOR 1Khz@8 ohm	>400:1					
INPUT SENSITIVITY	SELECTABLE (0.77V / 1.0V / 1.44V)					
INPUT IMPEDANCE	10K ohm Balanced to ground					
INPUT CONNECTORS	Female XLR-3					
OUTPUT CIRCUIT TYPE	Class AB	Class H				
OUTPUT CONNECTORS	4 Pole SPEAKON & Binding posts					
PROTECTIONS	Full short-circuit, Open-circuit, Thermal, Soft-start, DC voltage, Sub/Ultrasonic and RF					
LED INDICATORS (per channel)	POWER, SIGNAL, IPC, PROTECT					
PANEL CONTROLS	FRONT-2 input attenuators REAR- Ground lift, mode selection, compressor					
COOLING	Front-to-Back via 2 variable-speed fans					
POWER SUPPLY VOLTAGE	230V AC/50Hz					
OVER CURRENT PROTECTION	88-8A	88-12A	88-16A	98-20A	98-20A	98-20A
DIMENSION(mm)	482 x 453 x 88.8			482 x 468 x 132		
N WEIGHT /G WEIGHT (Kg)	23.5/26	26/28.5	27/29.5	33/36	34/37	35.5/38.5

The specifications above are correct at the time of printing of this manual. For improvement purposes, all specifications for this unit, including design and appearance, are subject to change without prior notice.

SIMPLIFIED EU DECLARATION OF CONFORMITY

Herewith Musikhaus Kirstein GmbH declares that the device is in compliance with the EU directive 2014/53/EU. You can download the EC declaration of conformity for this item under download link:

http://www.kirstein.de/docs/Konformitaetserklaerung/CE_Konformitaetserklaerung_00021735.pdf

http://www.kirstein.de/docs/Konformitaetserklaerung/CE_Konformitaetserklaerung_00021736.pdf

WEEE Declaration (Waste of Electrical and Electronic Equipment)

Your product has been designed and manufactured using quality materials and components that are recyclable and reusable. The symbol means that your product must be disposed separately from household waste at the end of its service life.

Dispose of this equipment at your local collection point or recycling center.

Please help to protect the environment in which we all live.

All specifications and appearances are subject to change without notice. All information was correct at time of printing. Musikhaus Kirstein GmbH does not guarantee for the accuracy or completeness of any description, photograph or statement contained in this manual. Printed colors and specifications may vary slightly from product. Products from Musikhaus Kirstein GmbH are only sold through authorized dealer. Distributors and dealers are not agents of Musikhaus Kirstein GmbH and have no authority to bind Musikhaus Kirstein GmbH legally in any way.

KIRSTEIN.de

Musikhaus Kirstein GmbH

Bernbeurener Str. 11

86956 Schongau – Germany

Email: info@kirstein.de

Telefon/Phone: 0049-8861-909494-0

Telefax/Fax: 0049-8861-909494-19

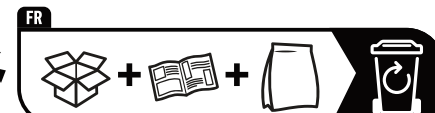

Points de collecte sur www.quefairedemesdechets.fr
Privilégiez la réparation ou le don de votre appareil !

